

EZ-BLE™ PROc™ EVALUATION BOARD CYBLE-202013-EVAL



The EZ-BLE™ PROc™ Evaluation Board (CYBLE-202013-EVAL) enables you to evaluate and develop applications on the EZ-BLE PROc Module (CYBLE-202013-11). The EZ-BLE PROc Module is a fully-integrated, 15.0 mm x 23.0 mm x 1.55 mm, programmable, Bluetooth® Smart module designed to reduce your time-to-market.

For more information, visit:

www.cypress.com/EZ-BLEModule - EZ-BLE Module home pages

www.cypress.com/EZ-BLEEval - EZ-BLE PROc Evaluation Board kit page

www.cypress.com/go/AN96841 - Getting started guide

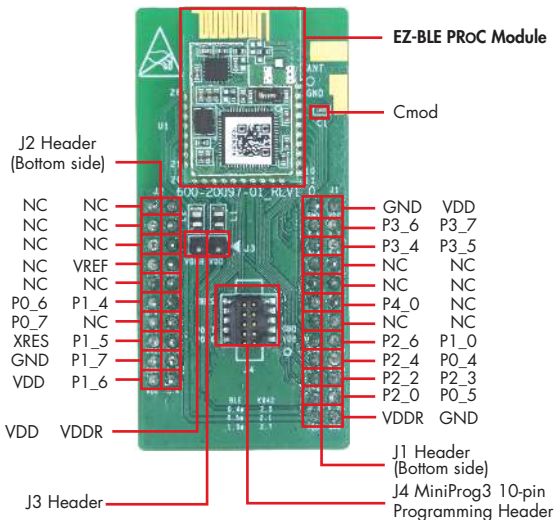

Fig 1: CYBLE-202013-EVAL Pinout Description

Note: To use the CYBLE-202013-EVAL board, you must separately purchase either the CY8CKIT-002 MINIPROG3 or the CY8CKIT-042-BLE PIONEER KIT.

EZ-BLE™ PROC™ EVALUATION BOARD

1: Connect the CYBLE-202013-EVAL to the CY8CKIT-002 (MiniProg3)

Connect a jumper on the J3 header

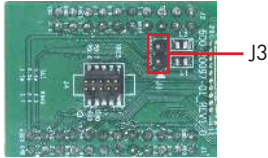

Fig 2: J3 Header

Connect the MiniProg3 to the J4 10-pin header



Fig 3: Programming/Debugging with MiniProg3

OR Plug the CYBLE-202013-EVAL on the CY8CKIT-042-BLE baseboard.

Note: Jumper on CYBLE-202013-EVAL's J3 header can be connected or disconnected.



Fig 4: Programming and debugging with CY8CKIT-042-BLE Pioneer Kit Baseboard

Pin Mapping between CY8CKIT-042-BLE (Base) and CYBLE-202013-EVAL (Eval)

(Base)	(Eval)	(Base)	(Eval)	(Base)	(Eval)	(Base)	(Eval)
GND	GND	P0_7	P0_7	P2_1	P0_5	P2_7	P1_0
VDDD, VDDA	VDD	P1_4	P1_4	P2_2	P2_2	P3_4	P3_4
VDDR	VDDR	P1_5	P1_5	P2_3	P2_3	P3_5	P3_5
XRES	XRES	P1_6	P1_6	P2_4	P2_4	P3_6	P3_6
VREF	VREF	P1_7	P1_7	P2_5	P0_4	P3_7	P3_7
P0_6	P0_6	P2_0	P2_0	P2_6	P2_6	P4_0	P4_0

2: Create a project using the CYBLE-202013-11 MPN and program/debug using PSoC® Creator™ 3.3 DP1

Visit www.cypress.com/support for technical support.