

**EPC9149: 36 - 60 V Input, 9 - 15 V,  
83 A Output Fixed Conversion Ratio  
1 kW LLC,  $\frac{1}{8}$ <sup>th</sup> Brick Size Module  
Quick Start Guide**

*EPC2218 and EPC2024*

Revision 3.2

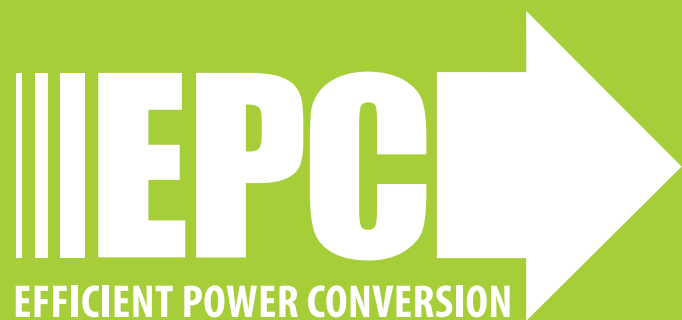

## DESCRIPTION

The EPC9149 demonstration board is a 1 kW, 48 V input to 12 V output LLC converter that operates as a DC transformer with fixed conversion ratio of 4:1. The simplified schematic diagram is shown in Figure 1. It features the 100 V rated **EPC2218** and 40 V rated **EPC2024** GaN FETs, the uP1966E and LMG1020 gate drivers as well as the Microchip dsPIC33CK32MP102 16-bit digital controller. Other features include:

- Peak efficiency: 97.5 % at 400 W
- High full-load efficiency: 96.7% @ 12 V delivering 83.3 A output
- 22.9 × 58.4 mm (0.90 × 2.30 inches)
- Low profile: 10 mm total converter thickness without heatsink
- Temperature rise: 70°C @ 12 V with 83.3 A output (with heatsink kit installed)
- Fixed switching frequency: 1 MHz
- Soft startup into full resistive load
- High power density: 1227 W/in<sup>3</sup> (excluding pins)

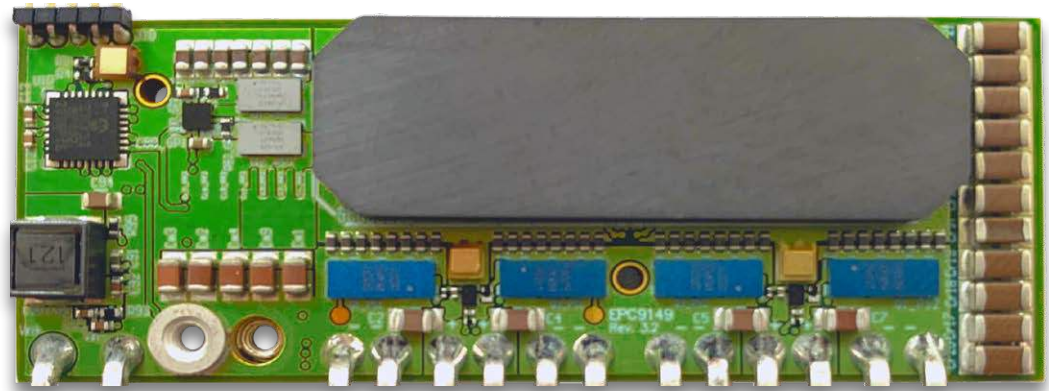

EPC9149 board

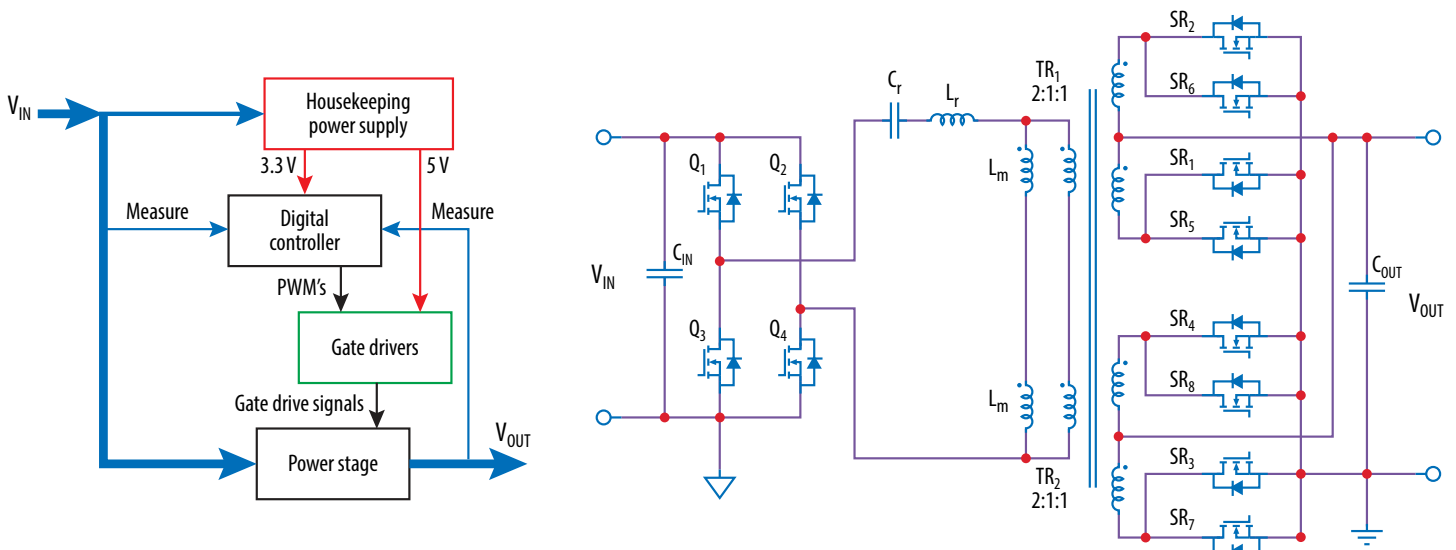

Figure 1: Simplified schematic diagram of the EPC9149 LLC Module

## REGULATORY INFORMATION

This converter is intended for evaluation purposes only. It is not a full-featured converter and cannot be used in final products. No EMI test was conducted. It is not FCC approved.

## FIRMWARE UPDATES

Every effort has been made to ensure all control features function as specified. It may be necessary to provide updates to the firmware. Please check the EPC website for the latest firmware updates.

Table 1: Electrical Characteristics (T<sub>a</sub> = 25 °C unless specified otherwise)

Symbol	Parameter	Conditions	Min	Typ	Max	Units
V <sub>IN</sub>	Input Voltage		36	48	60	V
V <sub>OUT</sub>	Output Voltage	Fixed ratio of 4:1 based on V <sub>IN</sub>		12		
I <sub>OUT</sub>	Output Current	Continuous*	0		83.3	A
f <sub>s</sub>	Switching Frequency			1		MHz
T <sub>rise</sub>	Temperature Rise	V <sub>IN</sub> = 48 V, I <sub>OUT</sub> = 83.3 A, thermal system installed, 400 LFM forced air, measured at heat-spreader		70		°C
V <sub>IN,on</sub>	Input UVLO turn on voltage			7.5		V
V <sub>IN,off</sub>	Input UVLO turn off voltage			5.5		
t <sub>OUT,rise</sub>	Output voltage rise time			3		ms

\* Requires adequate cooling

## HIGHLIGHTED PARTS

This converter is intended for evaluation purposes only. It is not a full-featured converter and cannot be used in final products. No EMI test was conducted. It is not FCC approved.

### Power Stage

The EPC9149 features a primary side full bridge and a dual secondary side center tapped half bridge configuration based on EPC2218 and EPC2024 eGaN fets. Available from EPC's website ([epc-co.com](http://epc-co.com)) are [EPC2218's datasheet](#) and [EPC2024's datasheet](#).

### Onboard power supply

The EPC9149 board includes logic and gate driver house-keeping power supplies that are powered from the main input supply voltage to the LLC board.

### Input and output voltage sense

Input and output voltages are measured by resistor dividers and fed back to the microcontroller to be used for control purposes.

### Transformer core

This module uses a customized transformer core with ML91S material from Hitachi metals (part number: U-36-4.57-12.2) which offers low core loss at high frequency operation. The drawing and dimensions of this core is shown in Figure 12. Two half core sections are inserted from top and bottom side of the board as shown in Figure 2 below. Proper spacers are also added in between to achieve the required magnetizing inductance.

Three layers of 2.5mils Kapton tap adding up to 7.5mils total thickness was used as spacer on each center pillar as shown in Figure 12. Very thin straps help to wrap the cores tightly together.

## MECHANICAL SPECIFICATIONS

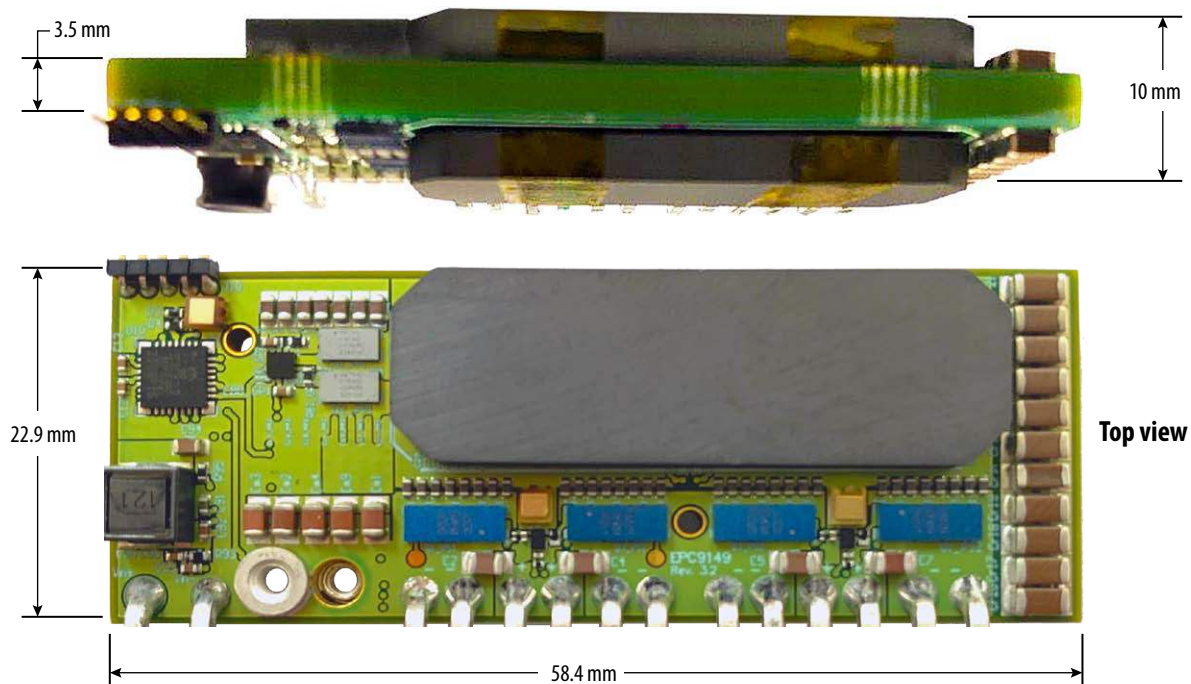

Figure 2: EPC9149 mechanical dimensions

**QUICK START PROCEDURE**

The EPC9149 LLC converter module is easy to set up for evaluation. Refer to Figures 3-4 and follow the procedure below for proper connection and measurement setup:

1. EPC9533 is the motherboard for EPC9149 where the main input and output power connections are located.
2. Attach the standoffs for EPC9533.
3. With power off, connect the input power supply to  $V_{IN+}$  and  $V_{IN-}$  as shown in Figure 3.
4. With power off, connect the load to  $V_{OUT+}$  and  $V_{OUT-}$  as shown in Figure 3.
5. Connect the input and output kelvin connections shown in Figure 3 to the respective measurement instruments.
6. Apply the input voltage and once operational, adjust the load within the operating range and observe the efficiency, temperature and other characteristics.
7. For shutdown, please follow the above steps in reverse. **(The input supply can be turned off as well)**

In order to measure the input and output currents, proper shunts can be connected in series with the corresponding connections. (input supply and load, respectively)

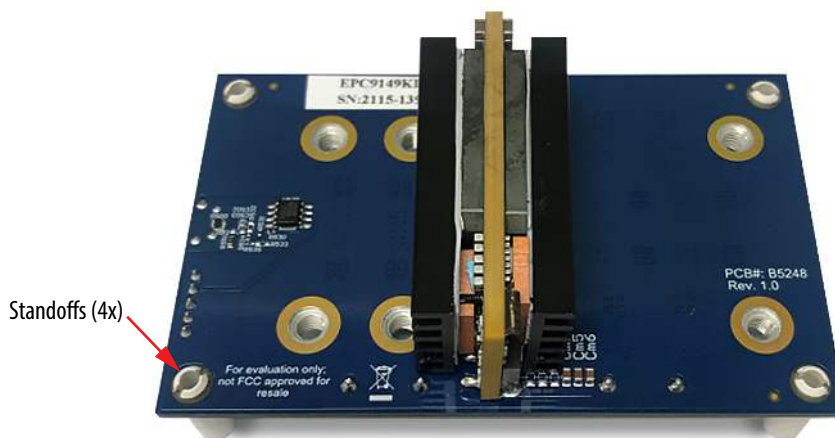
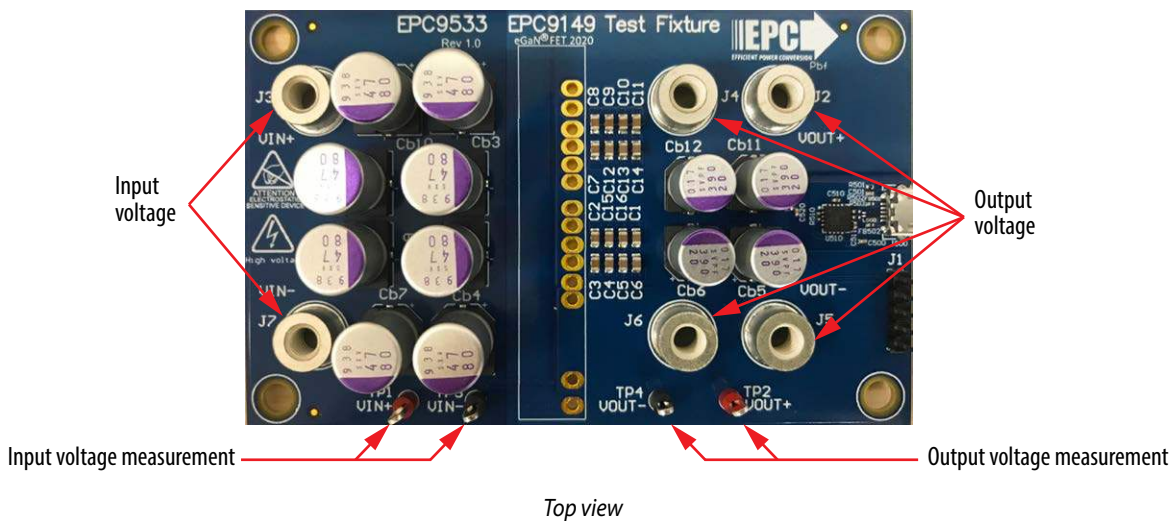

Figure 3: EPC9149 and motherboard assembly showing the input and output connections

### ELECTRICAL and THERMAL PERFORMANCE

The module provides maximum efficiency of 97.5% and full load efficiency of 96.7%.

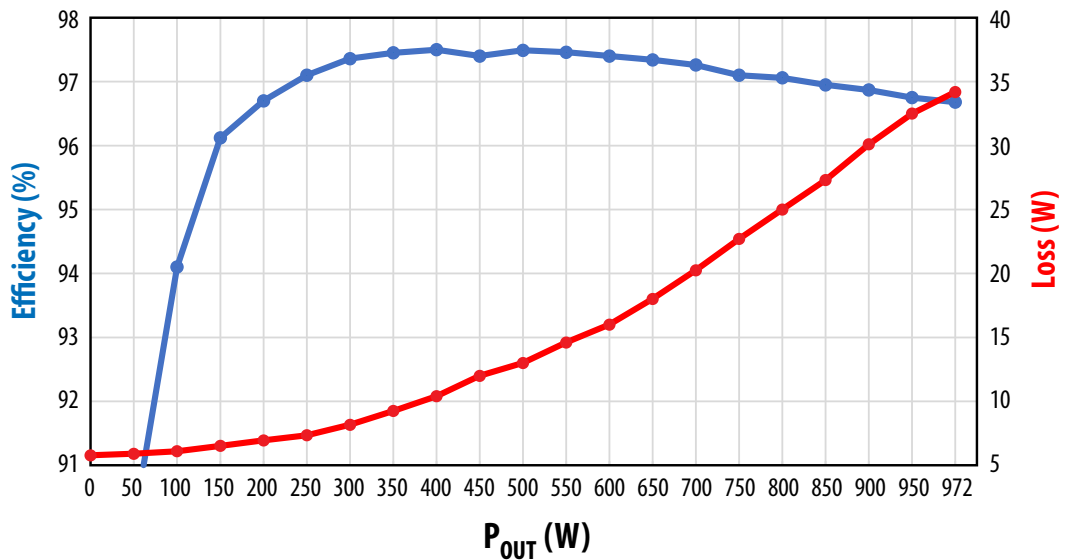

Figure 4: Total system efficiency and loss @ 12V output, 48V input voltage, 400LFM forced air cooling.

### Thermal performance

The measured thermal performance of the EPC9149 is shown in Figure 7, with the heatsink kit installed. The temperature rise for the hottest portion of the board is 70 °C when operating at full load with 400 LFM forced air cooling.

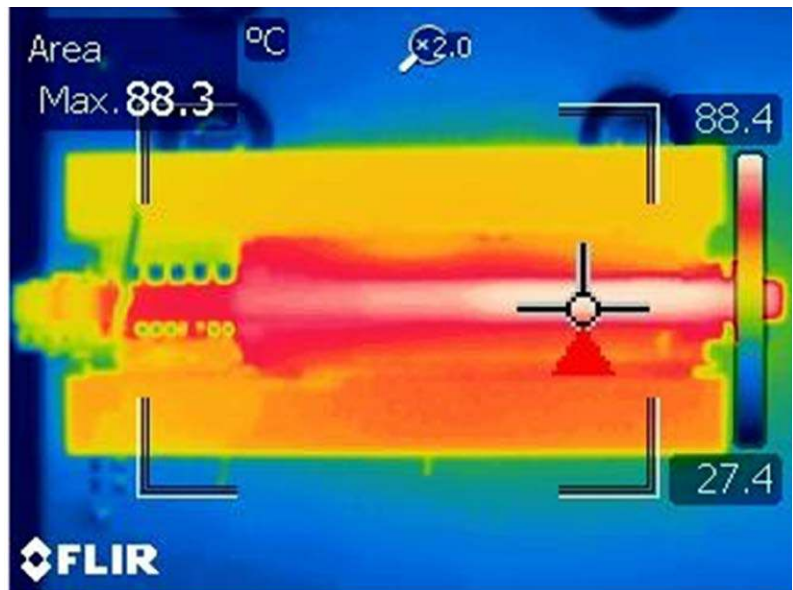
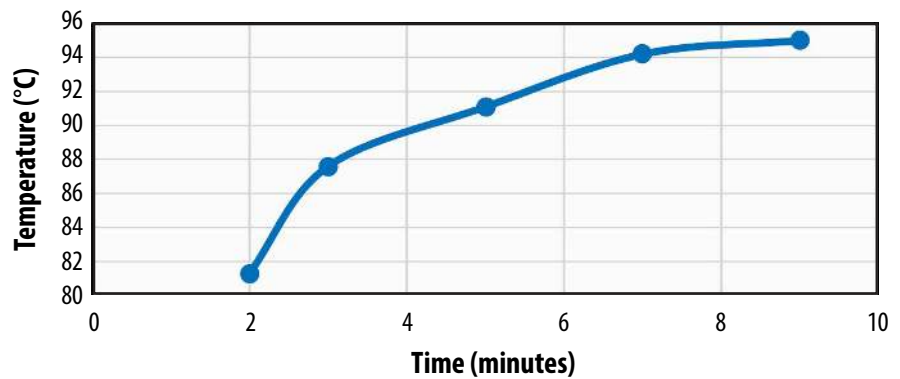

Figure 5: Thermal image of the EPC9149 operating at 48 V<sub>IN</sub>, 12 V and 83.3 A output, thermal steady state reached after 10 minutes, Top: primary FET junction temperature and Bottom: highest board temperature.



## THERMAL DERATING

Without sufficient thermal management, the output current capability is reduced. If the user decides to uninstall the heatsink, the module temperature should be monitored to ensure the maximum temperature does not exceed the rating.

## THERMAL MANAGEMENT

Thermal management is very important to ensure proper and reliable operation. The EPC9149 is intended for bench evaluation at normal ambient temperature. The addition of a heat-spreader or heatsink and forced air cooling can significantly increase the current rating of the power devices, but care must be taken to not exceed the absolute maximum die temperature of 150°C.

A combination of custom shape heat spreaders and a finned heatsink for the top and bottom side of the EPC9149 board are designed. The thermal solution assembly is shown in Figure 6. Copper heat spreaders (item 1 and 3) are placed on top of both primary and secondary side FETs to spread their heat to the outer structure. Two 1 mm height copper shims (item 2) are used to fill the gaps and help with cooling the board surface. It only requires a gap filler TIM to be added underneath of the heat spreader pieces to provide insulation and high thermal conductivity between the components and the metal surface of heat spreaders. Several mechanical shims help mounting the heat spreader on the PCB surface and maintaining required clearance between the heat spreader and component surfaces. Mechanical screws are inserted on the board to hold the entire mechanical structure together.

A step-by-step assembly guideline are presented. The needed parts are listed below.

- 2x heatsinks for top and bottom side (not identical)
- 2x Copper (Cu) heat spreaders for primary FETs (item #1)
- 2x M1.4 16 mm screws and 2x M1.4 nuts
- 2x M2 10 mm screws
- TIM pads TG-A1780 0.5 mm
- TIM pads TG-A6300 0.5 mm
- TIM gap filler Bergquist GF4000

Drawings and dimensions of these parts are provided in the Mechanical Bill of Materials (BOM) and in Figures 10, 11 and 12.

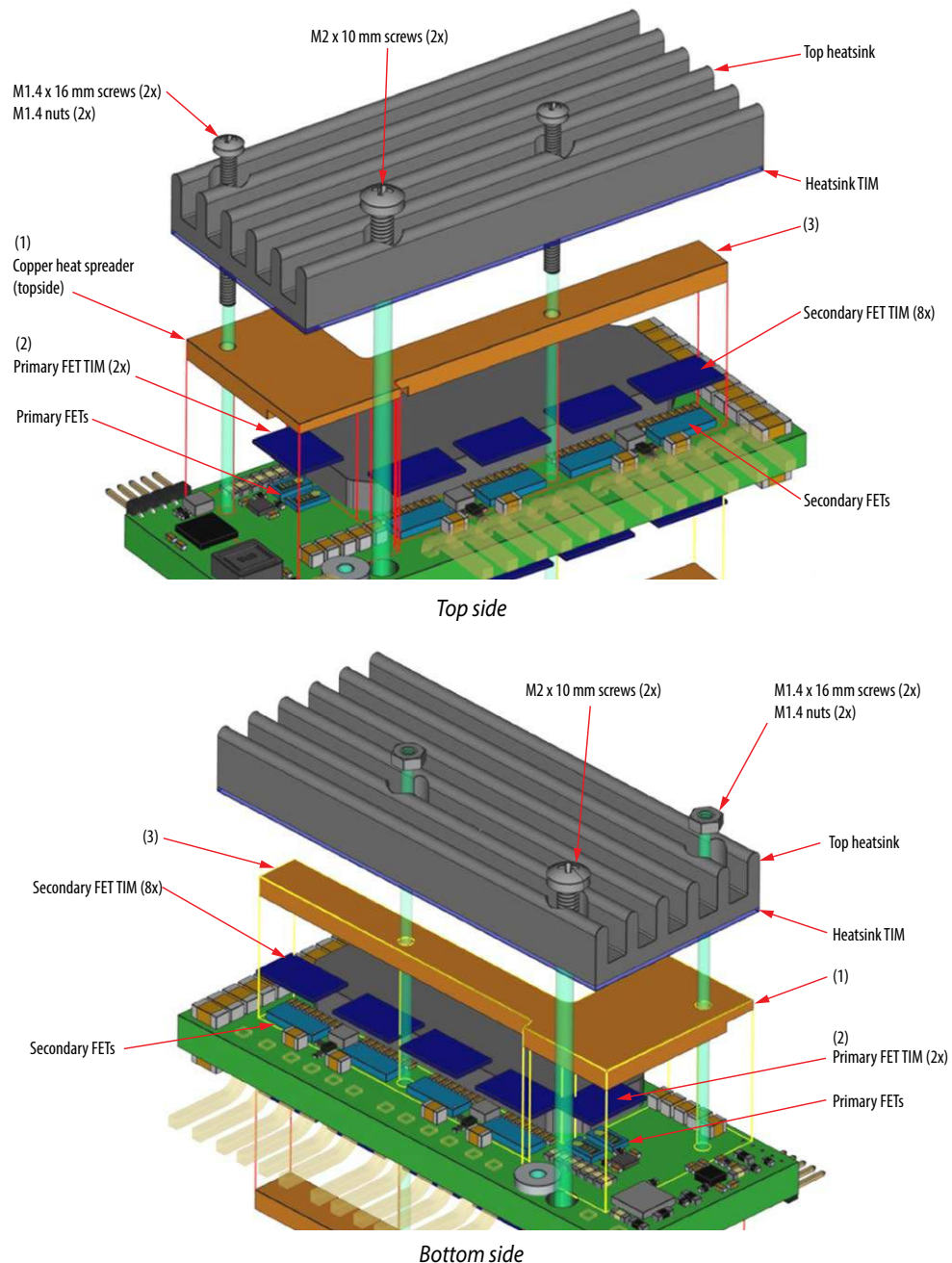
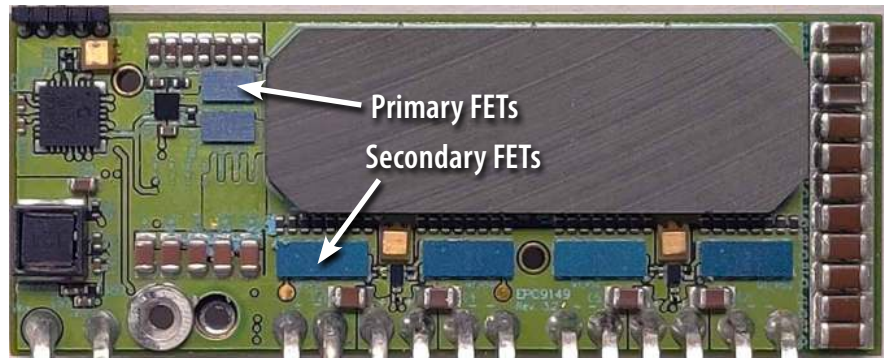

Figure 6: Thermal solution assembly process for the EPC9149 module

**THERMAL SOLUTION ASSEMBLY GUIDELINES**

1. Beginning at the top face of the PCB, note the position of the primary and secondary FETs



2. Add a small amount of **TIM gap filler** (Bergquist GF4000) on PCB next to Primary FETs

3. Place **TIM pads** (TG-A1780) on the primary and secondary FETs (Figure 12)

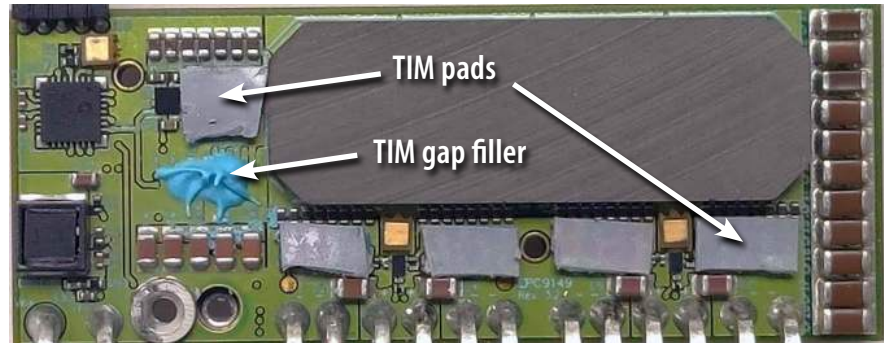

4. Place **heat spreaders** on the FETs, making sure the holes align with the drill holes on the PCB

**Note:** The two Cu heat spreaders for top and bottom sides are not identical (Figure 11)

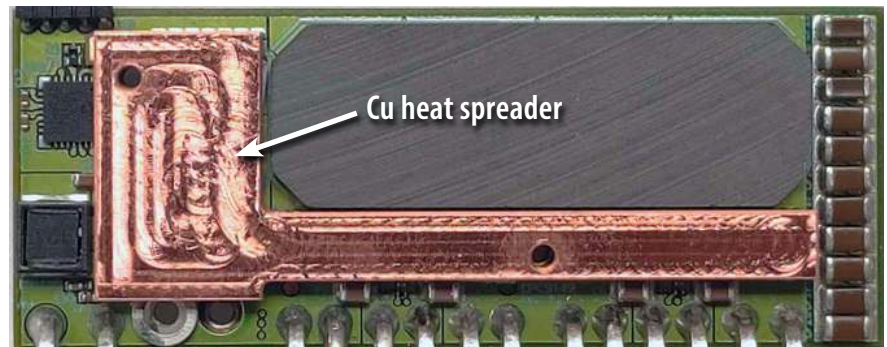

5. Place **TIM pad** (TG-A6200) on the backside of the heatsink (flat side) and align it to PCB holes (Figure 12)

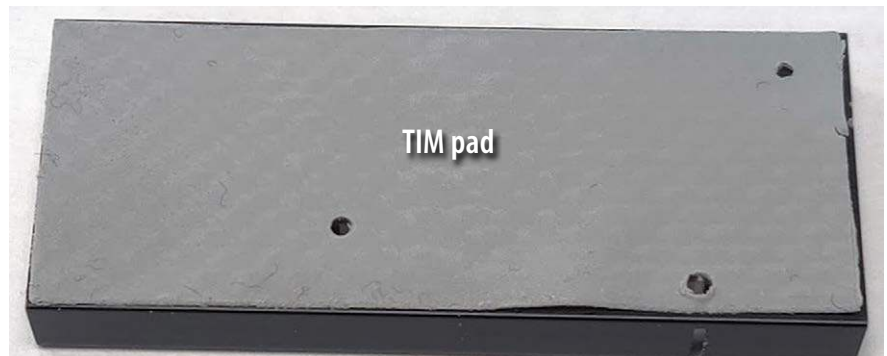

6. Use **M1.4** and **M2 screws** for assembly as shown in schematic; M2 is connected to threaded flange on PCB, do not fully tighten the M2 screw yet

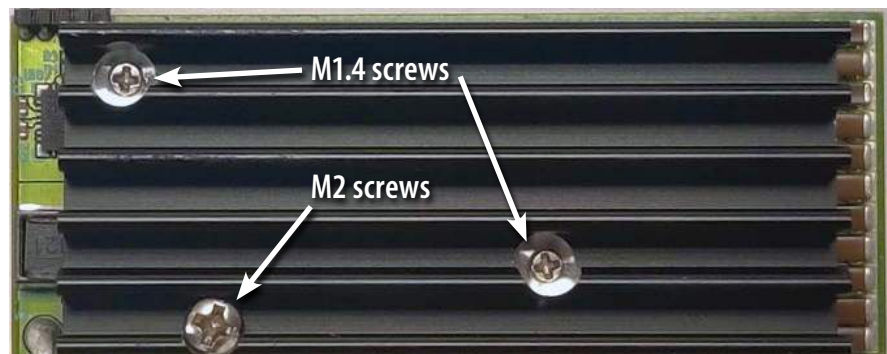



- Turn the PCB to the backside and note the placement of the FETs

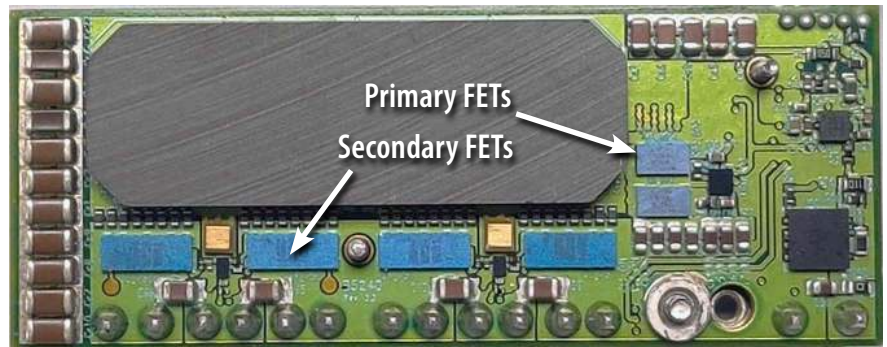

- Add a small amount of **TIM gap filler** (Bergquist GF4000) next to Primary FETs
- Place **TIM pad** (TG-A1780) cutouts to cover primary and secondary FETs (Figure 12)



- Place copper heat spreader on FETs, holes must align with PCB holes and the M1.4 screws

**Note:** The two Cu heat spreaders for top and bottom sides are not identical (Figure 11)

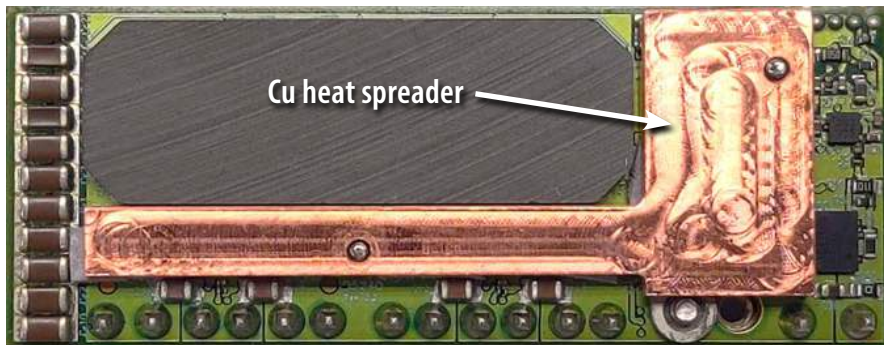

- Place TIM (TG-A6200) on backside of heatsink and align it to screw holes (Figure 12)



- Use **M1.4 nuts** and an **M2 screw** to assemble heatsink to the PCB as shown; M2 can be connected to threaded flange on PCB

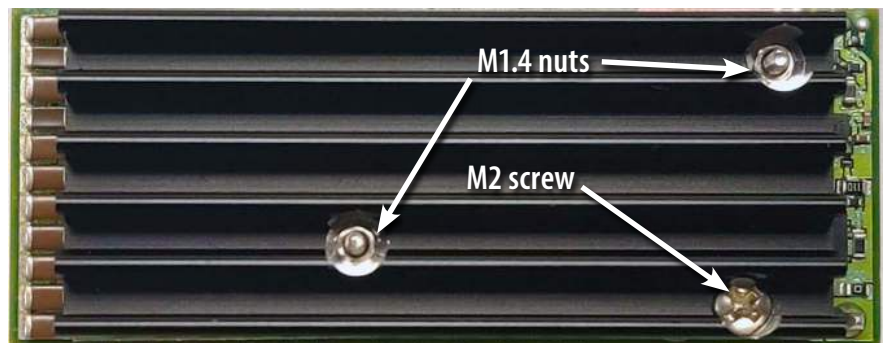



13. Tighten screws in sequence while keeping heatsink parallel to PCB

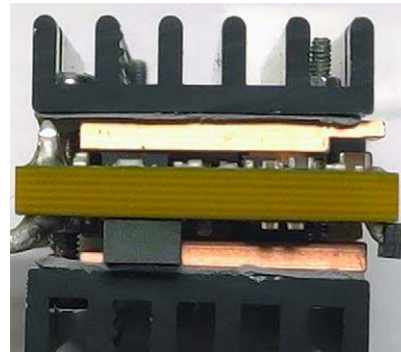

The choice of TIM needs to consider the following characteristics:

- **Mechanical compliance** – The TIM becomes compressed during heatsink attachment and exerts a force on the FETs. A maximum compression of 2:1 is recommended for maximum thermal performance and to constrain the mechanical force that maximizes thermal mechanical reliability.
- **Electrical insulation** – The backside of the eGaN FETs are substrate that are connected to source and the upper FET will thus be connected to the switch-node. The TIM must therefore provide insulation to prevent short-circuiting the upper FET to the ground.
- **Thermal performance** – The choice of thermal material will affect the thermal performance. Higher thermal conductivity materials will result in higher thermal performance.

EPC recommends T-Global: A1780- 500  $\mu$ m for the thermal interface material between FETs and heat spreaders and T-Global: A6200 for heatsinks. The gap filler TIM recommended is Bergquist GF4000.

## CONTROLLER

The EPC9149 LLC power module features a Microchip dsPIC33CK32MP102 Digital Signal Controller DSC. This 100 MHz single core device is equipped with dedicated peripheral modules for Switched-Mode Power Supply (SMPS) applications, such as a feature-rich 4-channel (8x output), 250 ps resolution pulse width modulation (PWM) logic, three 3.5 Msp/s Analog-To-Digital Converters (ADC), three 15 ns propagation delay analog comparators with integrated Digital-To-Analog Converters (DAC) supporting ramp signal generation, three operational amplifiers as well as Digital Signal Processing (DSP) core with tightly coupled data paths for high performance real-time control applications. The device used is the smallest derivative of the dsPIC33CK single core and dsPIC33CH dual core DSC families. The device used in this design comes in a 28 pin 4x4 mm UQFN package, specified for ambient temperatures from -40 to +125° C.

The dsPIC33CK device is used to drive the converter in a fully digital fashion. Input voltage and output voltage measurements are fed back to the dsPIC and read using two independent core ADCs.

## PROGRAMMING

The Microchip dsPIC33CK controller can be re-programmed using the MPLAB ICD4 or other Microchip programmer tools and through the 5-pin header on EPC9149 board shown below. RJ11 to ICSP adapter 02-10310-R1 from microchip is used to interface programmer and the main board (Fig. 11(b)). (Please refer to [www.microchip.com](http://www.microchip.com) for available options)

EPC9997 board is designed to be specifically used as an ICSP adapter as shown in Fig. 9(a) as well.

**Please make sure the programming is performed only when the module is not running and no input voltage is applied.**

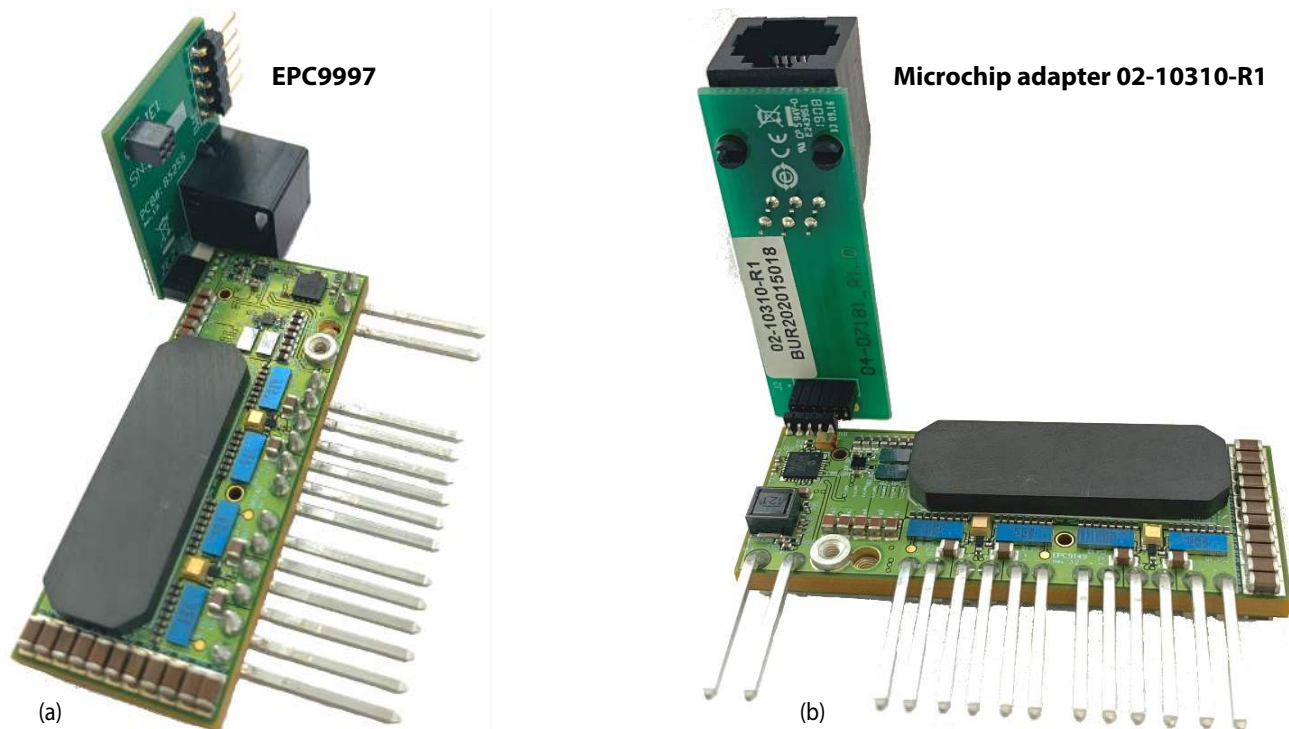

Figure 9: Programming connection options

### Programming with HEX file

Download the latest MPLAB® X IPE from Microchip website and follow the five steps below:

<https://www.microchip.com/mplab/mplab-integrated-programming-environment>

#### 1. Enable Advanced Mode:

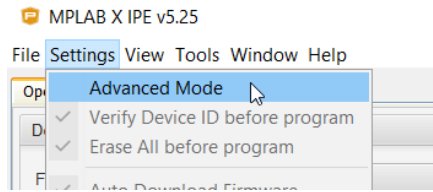

#### 5. Erase device, and then program device:

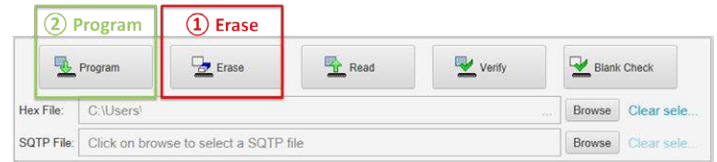

#### 2. Select Device: dsPIC33CK32MP102 and then apply:

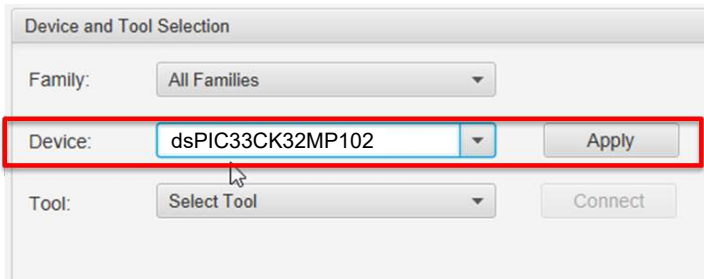

#### 3. Select programming tool and then connect:

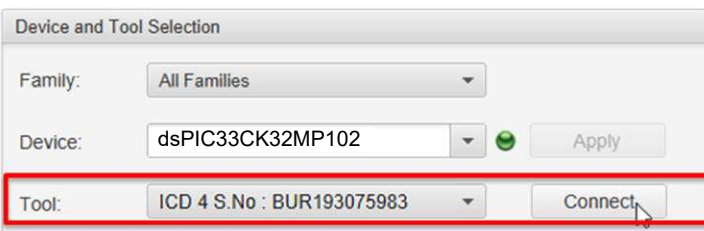

#### 4. Click 'Browse' to select the provided .hex file:

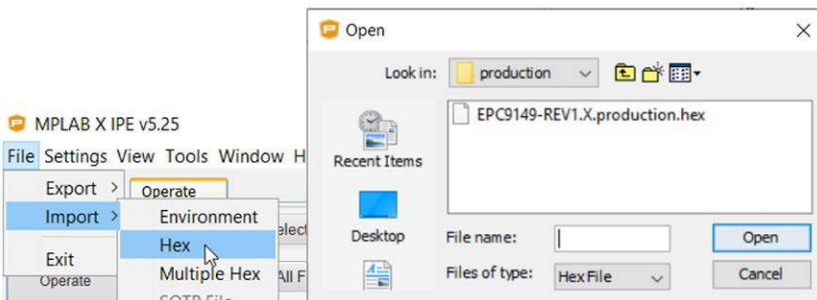

**Optional: Enable 'Power target circuit from programming tool' from left panel 'Power' tab so that no additional power supply is necessary during programming:**

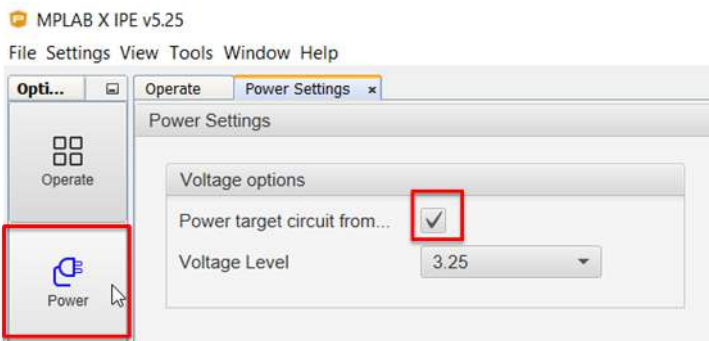



THERMAL MECHANICAL DRAWINGS

Table 2: Bill of Materials - Thermal-Mechanical components

Item	Qty	Part Description	Manufacturer	Part #
1	1	Heat Sink Top Side	Fischer Elektrik	SK 476 50 SA
2	1	Heat Sink Bottom Side	Fischer Elektrik	SK 476 50 SA
3	1	Integrated Heat Spreader (Top)	Prototype-Shortrun	Custom part
4	1	Integrated Heat Spreader (Bottom)	Prototype-Shortrun	Custom part
5	2	Primary TIM pad	T-Global	TG-A1780 X 0.5 mm
6	8	Secondary TIM pad	T-Global	TG-A1780 X 0.5 mm
7	2	Heat Sink TIM pad	T-Global	TG-A6200 X 0.5 mm
8	2	M2-0.40x10mm Screws	Metric Screws US	10047
9	2	M1.4x16mm Screws	Metric Screws US	21856
10	2	M1.4 Hex Nuts	Metric Screws US	20680

Item	Qty	Part Description	Manufacturer	Part #
1	1	Heat Sink Top Side	Fischer Elektrik	SK 476 50 SA

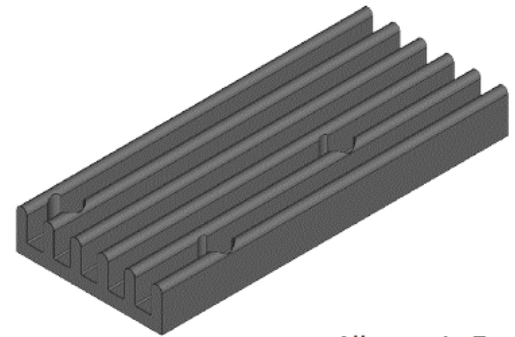
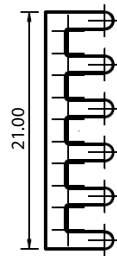
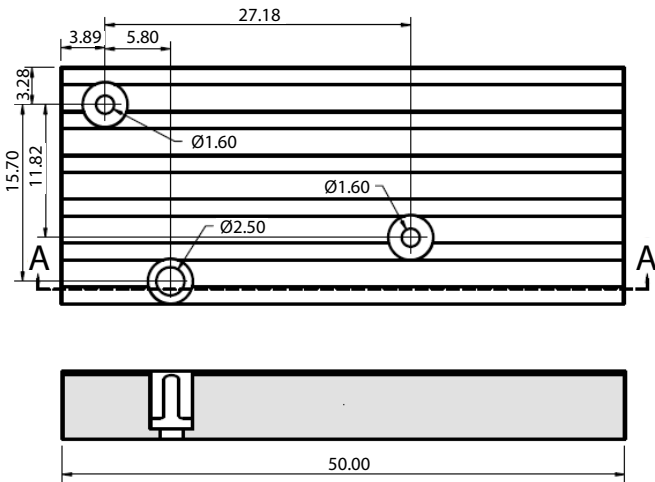

(a)

All □ Ø4 ↴5  
All units in mm

Item	Qty	Part Description	Manufacturer	Part #
2	1	Heat Sink Bottom Side	Fischer Elektrik	SK 476 50 SA

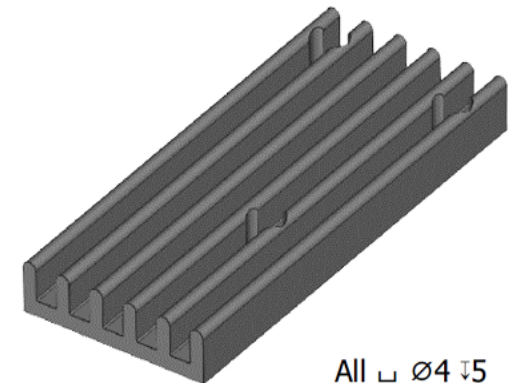
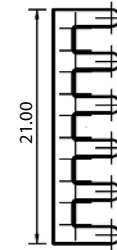
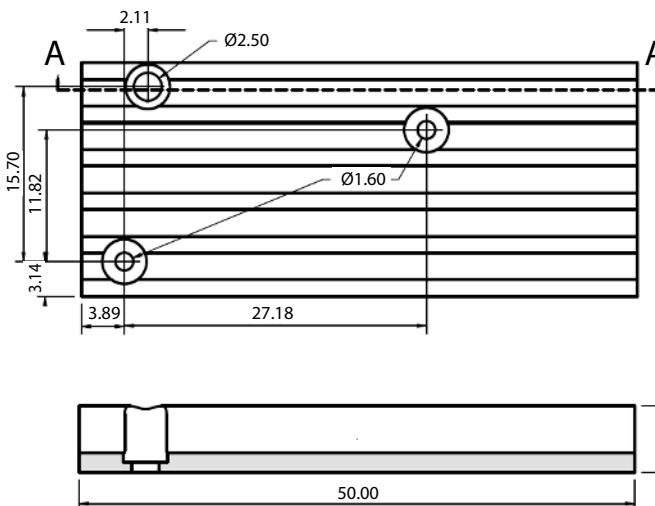

(b)

All □ Ø4 ↴5  
All units in mm

Figure 10: (a) Top side heatsink drawing, (b) Bottom side heatsink

Item	Qty	Part Description	Part #
3	1	Integrated Heat Spreader (Top)	Custom part

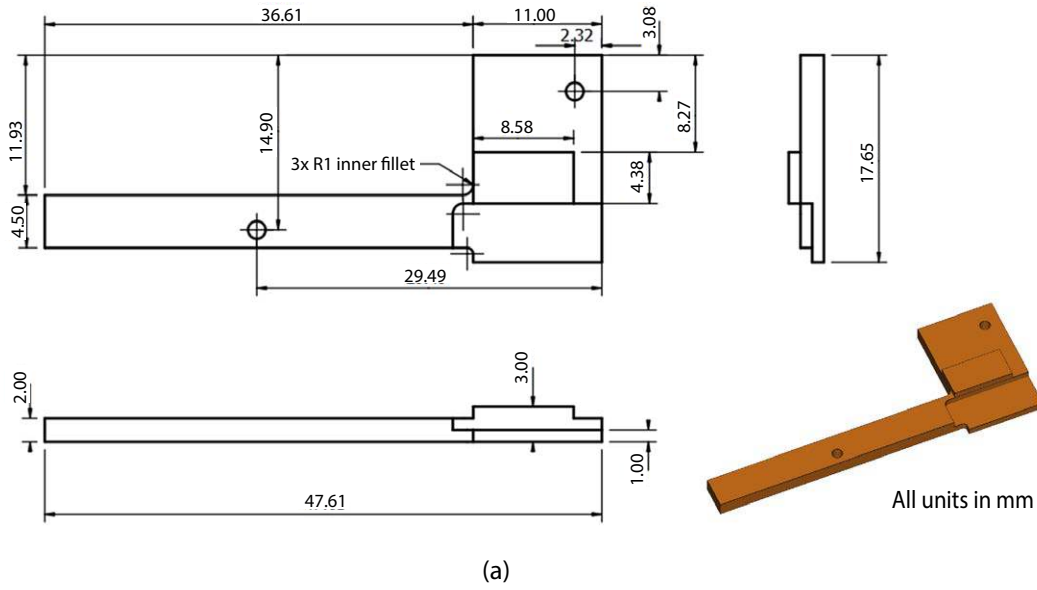

Item	Qty	Part Description	Part #
4	1	Integrated Heat Spreader (Bottom)	Custom part

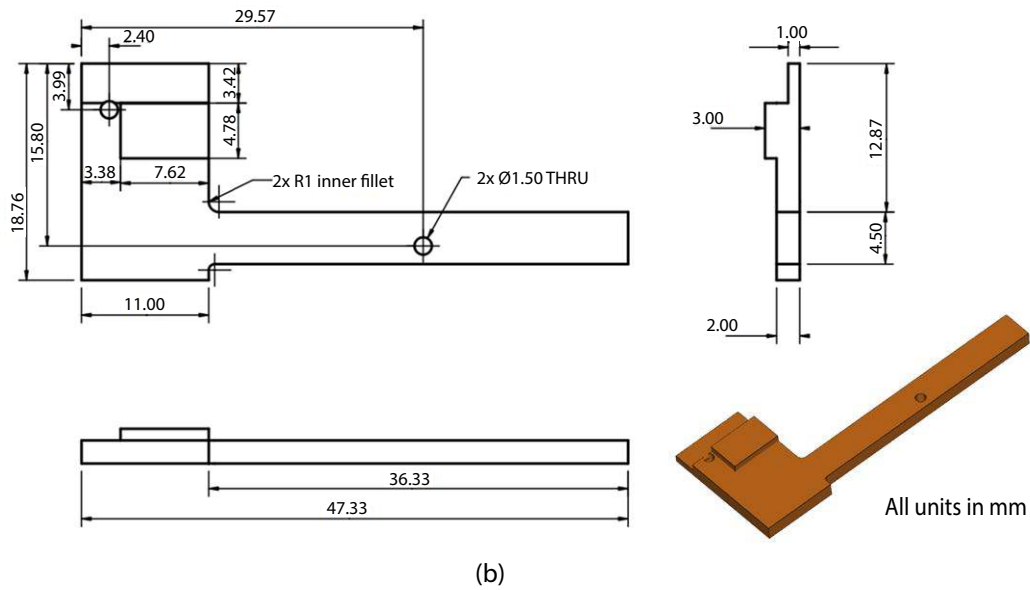

Figure 11. Integrated heat spreader drawing for (a) top-side and (b) bottom-side

Item	Qty	Part Description	Manufacturer	Part #
5	2	Primary TIM pad	T-Global	TG-A1780 X 0.5 mm
6	8	Secondary TIM pad	T-Global	TG-A1780 X 0.5 mm
7	2	Heat Sink TIM pad	T-Global	TG-A6200 X 0.5 mm

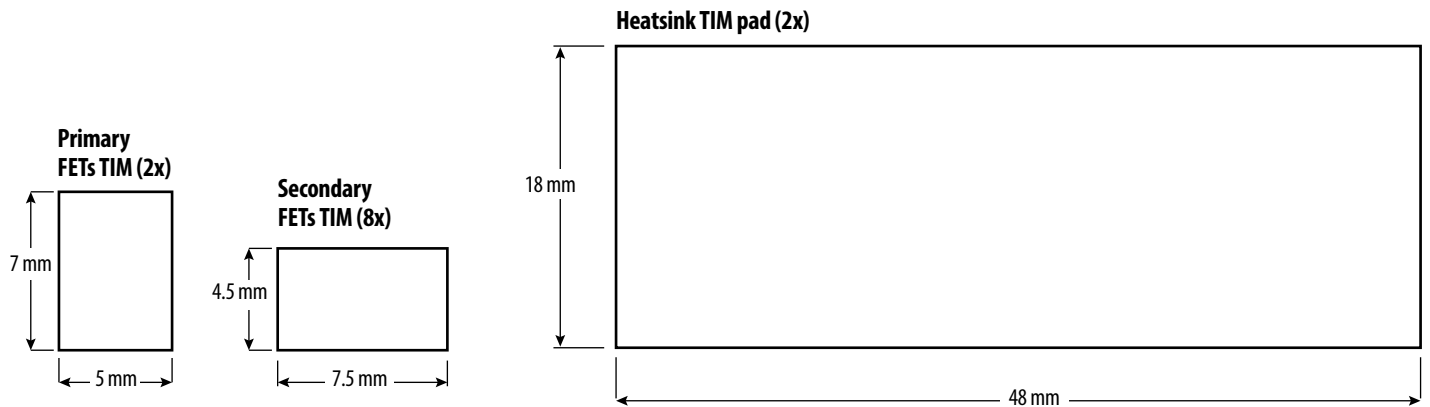

Figure 12: Drawings and dimensions of TIM pad cutouts for primary FETs, secondary FETs and heatsinks.

Item	Qty	Part Description	Manufacturer	Part #
8	2	M2-0.40x10mm Screws	Metric Screws US	10047
9	2	M1.4x16mm Screws	Metric Screws US	21856
10	2	M1.4 Hex Nuts	Metric Screws US	20680

### CORE DRAWING AND DIMENSIONS

All units in mm

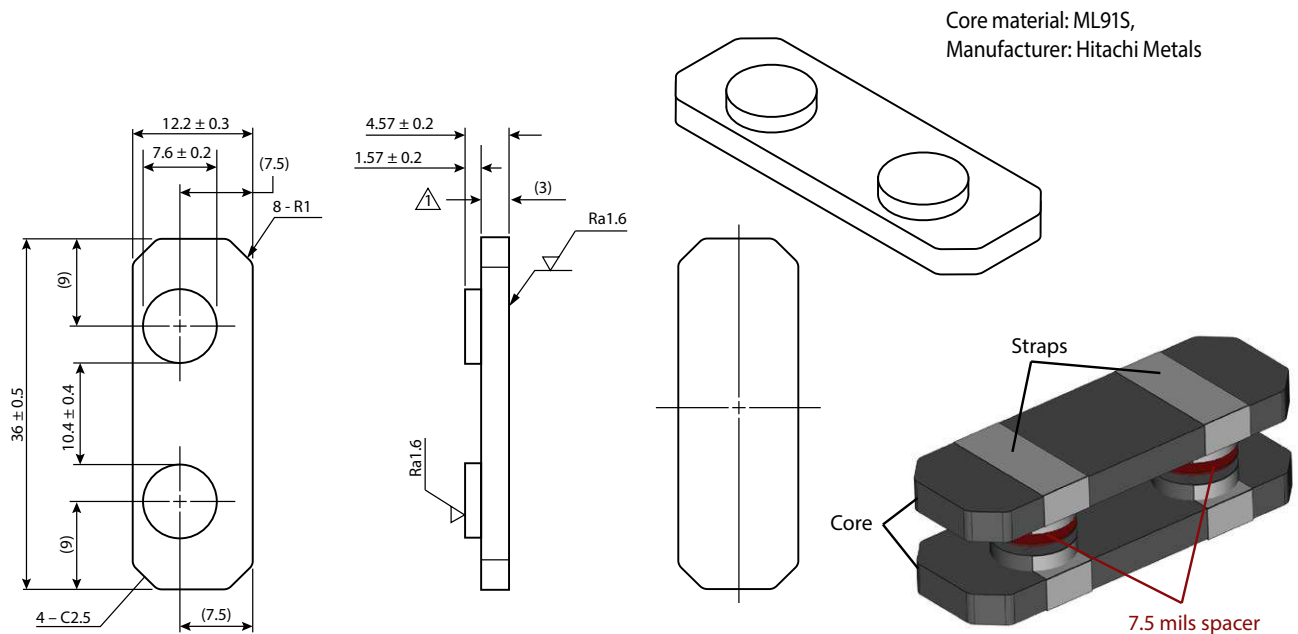

Figure 13: Drawing with dimensions of the transformer core



Table 3: Bill of Materials - EPC9149 module electrical

Item	Qty	Reference	Part Description	Manufacturer	Part #
1	2	C1, C6	CAP CER 0402 10 nF 25 V X7R 5%	Kemet	C0402C103J3REC
2	8	C2, C4, C5, C7, C58, C63, C65, C66	22 µF ±20% 25 V Ceramic Capacitor X5R 0805	Murata	GRT21BR61E226ME13L
3	1	C10	10000 pF ±10% 16 V Ceramic Capacitor X7R 0402	Kemet	C0402C103K4RECAUTO
4	5	C11, C12, C13, C81_GP1, C81_GP2	0.1 µF, 25 V, 0402, X7R	Yageo	CC0402KRX7R8BB104
5	64	C14_PS1, C14_PS2, C15_PS1, C15_PS2, C16_PS1, C16_PS2, C17_PS1, C17_PS2, C18_PS1, C18_PS2, C19_PS1, C19_PS2, C20_PS1, C20_PS2, C24_PS1, C24_PS2, C25_PS1, C25_PS2, C26_PS1, C26_PS2, C27_PS1, C27_PS2, C28_PS1, C28_PS2, C29_PS1, C29_PS2, C30_PS1, C30_PS2, C31_PS1, C31_PS2, C32_PS1, C32_PS2, C33_PS1, C33_PS2, C34_PS1, C34_PS2, C35_PS1, C35_PS2, C36_PS1, C36_PS2, C44_PS1, C44_PS2, C45_PS1, C45_PS2, C46_PS1, C46_PS2, C47_PS1, C47_PS2, C48_PS1, C48_PS2, C49_PS1, C49_PS2, C50_PS1, C50_PS2, C51_PS1, C51_PS2, C52_PS1, C52_PS2, C53_PS1, C53_PS2, C54_PS1, C54_PS2, C55_PS1, C55_PS2	2.2 µF ±10% 25 V Ceramic Capacitor JB 0402	TDK	C1005JB1E225K050BC
6	2	C21, C22	CAP CER 1 µF 25 V X5R 0402	Murata	GRT155R61E105ME01D
7	1	C23	CAP CER 22 µF 6.3 V 0402	Samsung	CL05A226MQ5N6J8
8	4	C40_GS11, C40_GS12, C40_GS21, C40_GS22	CAP CER 4.7 µF 6.3 V X5R 0201	Murata	GRM035R60J475ME15D
9	4	C41_GS11, C41_GS12, C41_GS21, C41_GS22	CAP CER 33 pF 25 V C0G/NP0 0201	Murata	GRM0335C1E330JA01D
10	2	C80_GP1, C80_GP2	CAP CER 1 µF 25 V X5R 0402	TDK	C1005X5R1A475K050BC
11	1	C90	CAP CER 22 µF 6.3 V 0402	Taiyo Yuden	HMK107C7224KAHTE
12	1	C91	CAP CER 4.7 µF 6.3 V X5R 0201	TDK	C1005X6S1C105K050BC
13	1	C92	CAP CER 33PF 25 V C0G/NP0 0201	TDK	C1005X7S2A103K050BB
14	1	C93	CAP CER 4.7 µF 10 V X5R 0402	TDK	CGA2B3X7S2A332M050BB
15	1	C94	CAP CER 0.22 µF 100 V X7S 0603	Kemet	C1206C224K3JAC7800
16	1	C95	1 µF ±10% 16 V Ceramic Capacitor X6S 0402	Murata	GRM155R71H103KA88D
17	14	Ci1_PP1, Ci1_PP2, Ci2_PP1, Ci2_PP2, Ci3_PP1, Ci3_PP2, Ci4_PP1, Ci4_PP2, Ci5_PP1, Ci5_PP2, Ci6_PP1, Ci6_PP2, Ci7_PP1, Ci7_PP2	CAP CER 10000 pF 100 V X7S 0402	Taiyo Yuden	HMK107C7224
18	10	Cm1, Cm2, Cm3, Cm4, Cm5, Cm6, Cm7, Cm8, Cm9, Cm10	750 pF ±5% 50 V Ceramic Capacitor C0G, NP0 0402	TDK	C2012X7S2A105M125AB
19	22	Cr1, Cr2, Cr3, Cr4, Cr5, Cr6, Cr7, Cr8, Cr9, Cr10, Cr11, Cr12, Cr13, Cr14, Cr15, Cr16, Cr17, Cr18, Cr19, Cr20, Cr21, Cr22	Cap Cer 220 nF, 25V U2J 1206	Kemet	C1206C224K3JAC7800
20	4	FB_GS11, FB_GS12, FB_GS21, FB_GS22	FERRITE BEAD 240 Ω 0201 0.35 A 380 mΩ	Murata	BLM03AX241SN1D
21	1	J10	5 pin header		
22	1	L90	120 µH Shielded Wirewound Inductor 950 mA 100 mΩ	Bourns	SRR4828A-121M
23	4	Q1_PP1, Q1_PP2, Q2_PP1, Q2_PP2	100 V 60 A 3.2 mΩ	EPC	EPC2218
24	8	Q1_PS1, Q1_PS2, Q2_PS1, Q2_PS2, Q3_PS1, Q3_PS2, Q4_PS1, Q4_PS2	40 V 60 A 1.5mE	EPC	EPC2024
25	1	R1	39 kΩs ±0.1% 0.2 W, 1/5 W Chip Resistor 0603	Panasonic	RC0603FR-07110KL
26	1	R2	4.87 kΩs ±0.1% 0.063 W, 1/16 W Chip Resistor 0402	Panasonic	ERA-2AEB4871X
27	1	R3	RES SMD 20 Ω 1% 1/16 W 0402	Yageo	RC0402FR-0720RL
28	1	R4	RES SMD 48.7 KΩ 0.1% 1/16 W 0402	Panasonic	ERA-2AEB183X
29	1	R5	RES SMD 3.48 KΩ 0.1% 1/16 W 0402	Panasonic	ERA-2AEB4751X
30	1	R11	FERRITE BEAD 180 Ω 0603 1LN	Murata	BLM18PG181SN1D
31	1	R16	10K 0402	Yageo	RC0402JR-0710KL
32	1	R21	0 Ωs Jumper 1/16 W Chip Resistor 0402	Yageo	RC0402JR-070RL
33	4	R40_GS11_Off, R40_GS12_Off, R40_GS21_Off, R40_GS22_Off	RES 0.47 Ω 1% 1/10 W 0201	ROHM	UCR006YVPLR470
34	4	R40_GS11_On, R40_GS12_On, R40_GS21_On, R40_GS22_On	RES SMD 2 Ω 5% 1/20 W 0201	Panasonic	ERJ-1GNJ2ROC
35	4	R41_GS11, R41_GS12, R41_GS21, R41_GS22	RES 10K Ω 1% 1/20 W 0201	Panasonic	RMCF0201FT10K0
36	4	R80_GP1, R80_GP2, R82_GP1, R82_GP2	RES SMD 1 Ω 5% 1/10 W 0402	Yageo	RC0402FR-071RL
37	1	R90	0 Ωs Jumper 0.1 W, 1/10 W Chip Resistor 0603	Panasonic	ERJ-3GEY0R00V
38	1	R91	86.6 k 0603	Yageo	RC0603FR-0786K6L
39	1	R92	16.5 k 0402	Yageo	RC0402FR-0716K5L
40	1	R93	RES SMD 1 Ω 1% 1/16 W 0402	Yageo	RC0402JR-0768KL
41	1	R94	11.3 kΩs ±0.5% 0.063 W, 1/16 W Chip Resistor 0402	Yageo	RT0402DRD0711K3L
42	1	R95	3.65 k 0603	Yageo	RC0402FR-073K65L
43	1	R96	127 k 0603	Yageo	RC0603FR-07127KL
44	2	SOB, SOT	Round Standoff Threaded M2x0.4 Steel 0.039" (1.00 mm)	Würth	9774010243R
45	1	U10	dsPIC Automotive, AEC-Q100, dsPIC™ 33CK Microcontroller IC 16-Bit 100 MHz 32KB (32K x 8) FLASH 28-UQFN (4x4)	Microchip	DSPIC33CK32MP102T-I/M6
46	1	U20	Linear Voltage Regulator IC 1 Output 500 mA 6-WSON (2x2)	TI	TLV7533PDRVR
47	4	U40_GS11, U40_GS12, U40_GS21, U40_GS22	LMG1020 Low side GaN driver	Texas Instruments	LMG1020YFF
48	2	U80_GP1, U80_GP2	eGaN 100 V Half Bridge Gate Driver	uPI	uP1966E
49	1	U90	Buck Regulator 100 V, 300 mA	Texas Instruments	LM5018SD/NOPB

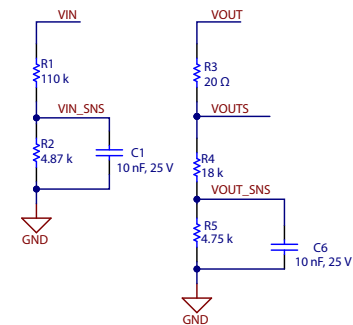
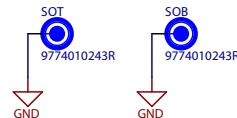
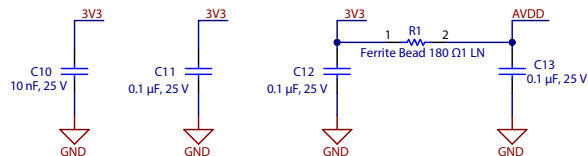
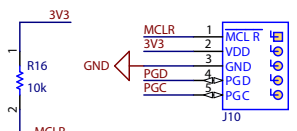
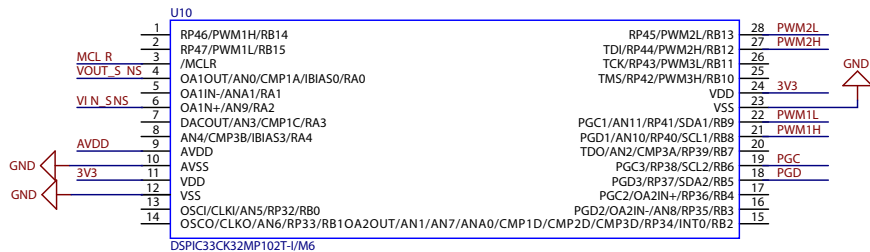
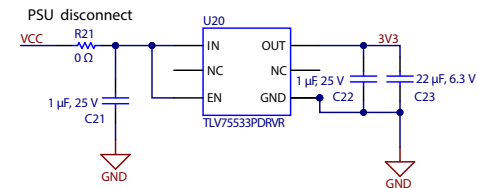
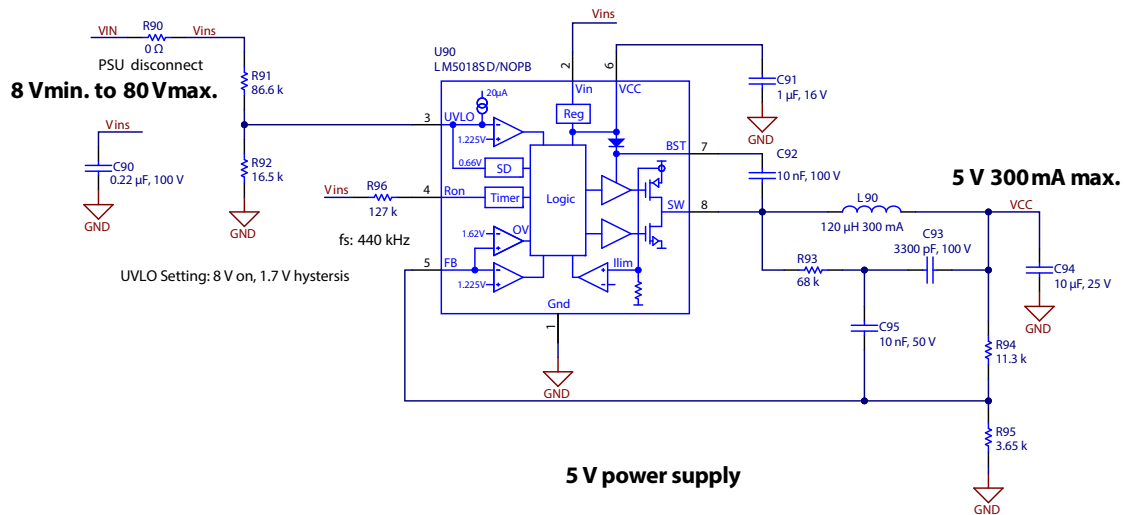
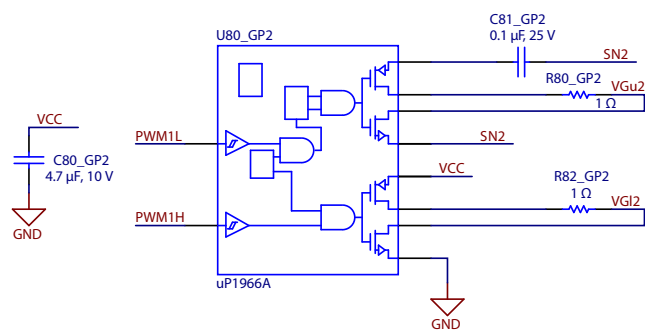
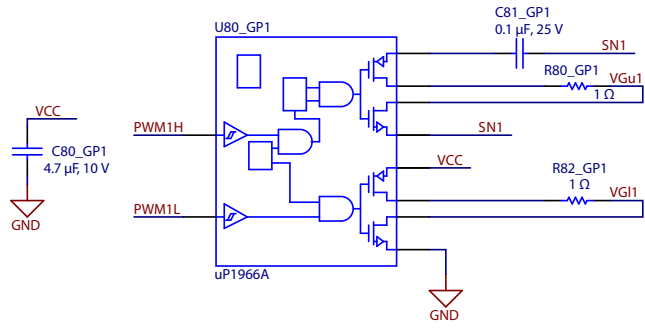
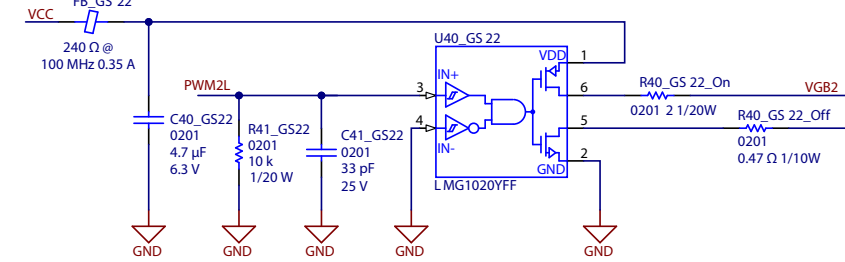
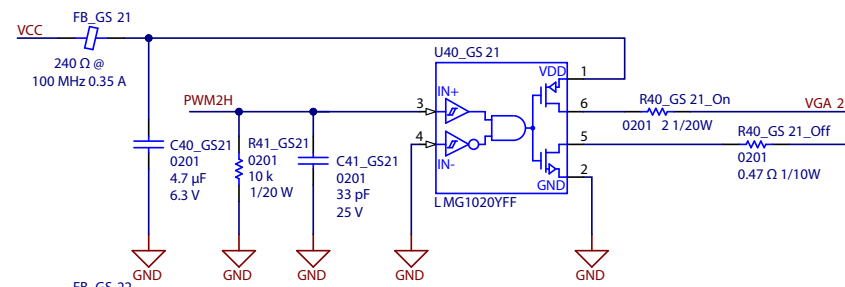
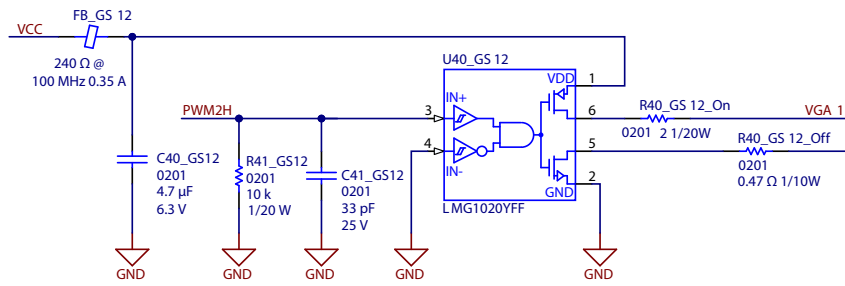
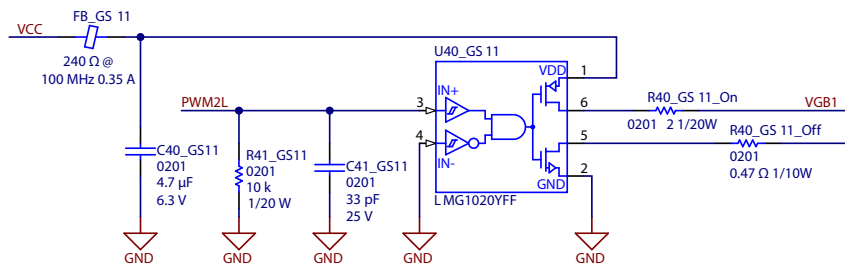

Figure 14: **Control stage:** Microcontroller, input and output voltage sensing, 5V bias supply for the drivers and 3.3V regulator for the dSPIC supply



**Primary-side Gate Drivers**



**Secondary-side Gate Drivers**

Figure 15: **Driver stage:** For the primary and secondary side FETs



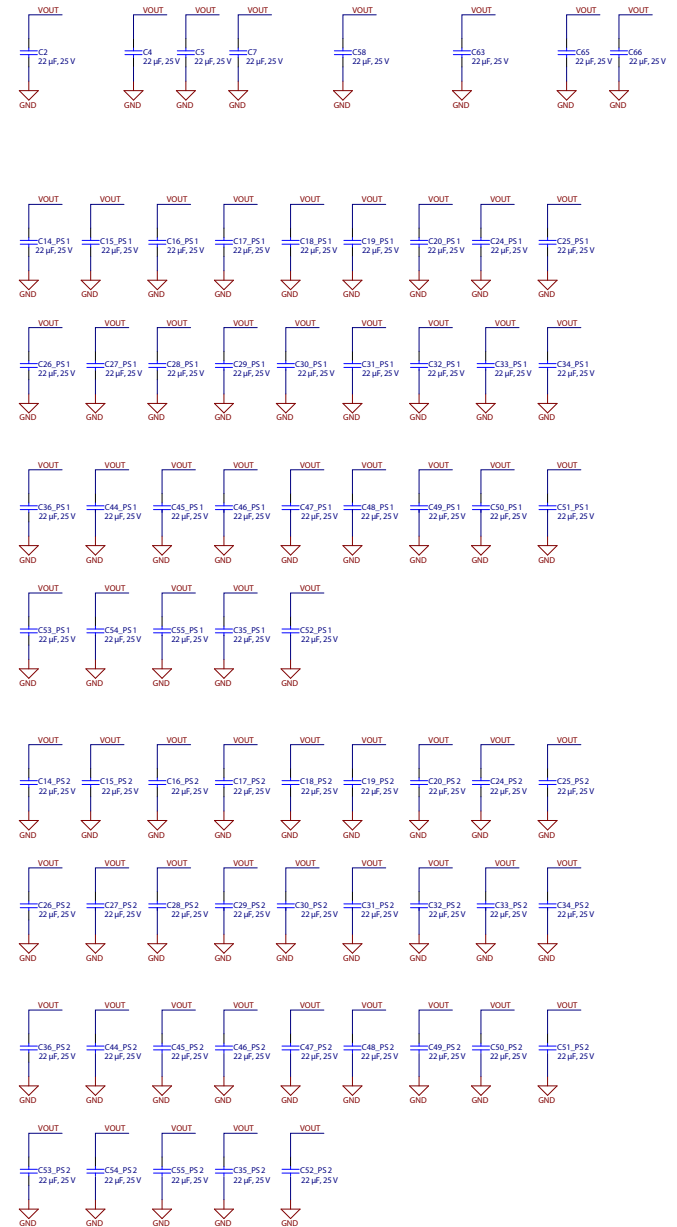
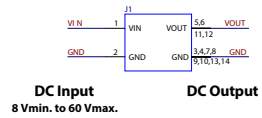
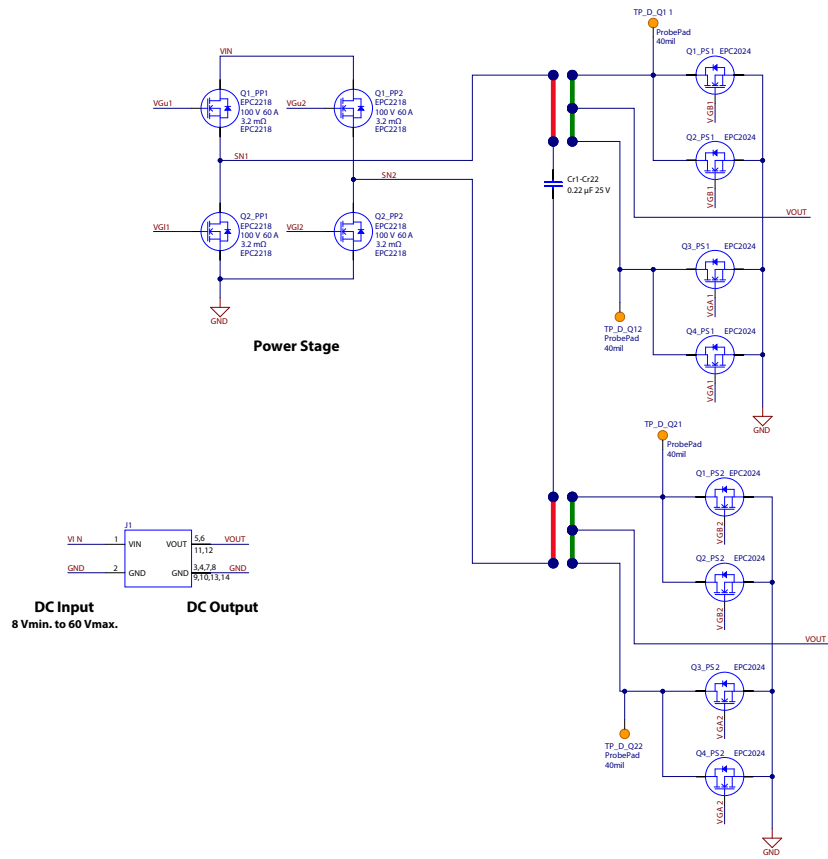
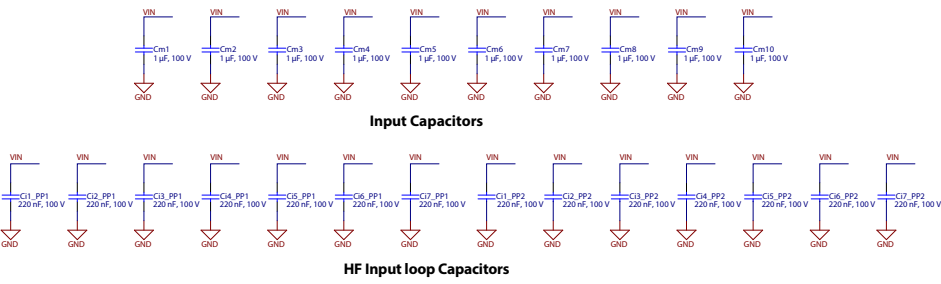
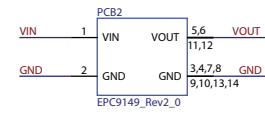
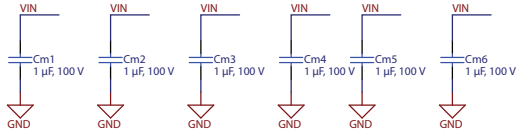
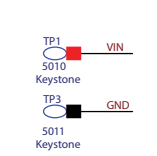
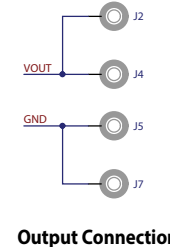
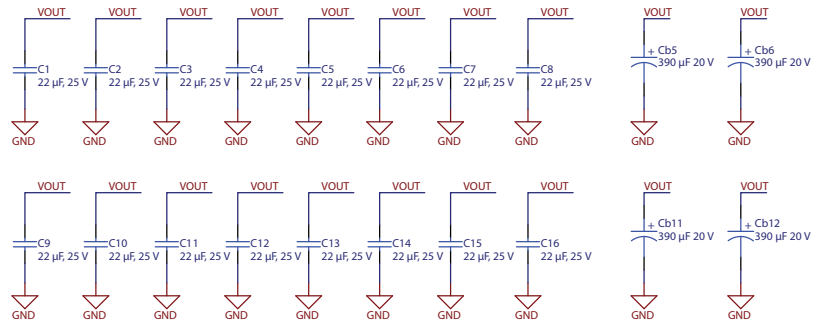
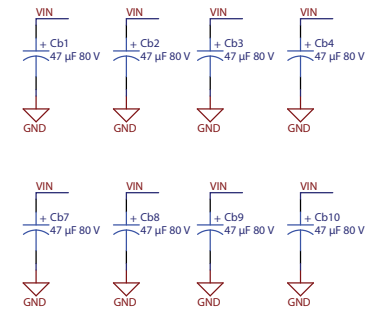
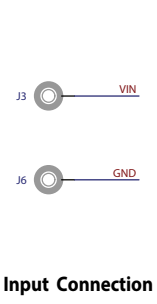
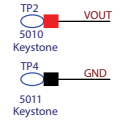

Figure 16: Power stage: Topology including FETs, transformer and input, output and resonant capacitors



EPC9149 Rev2\_0 LLC resonant converter



**Input Voltage Measurement**

**Input Capacitors**

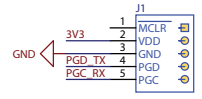
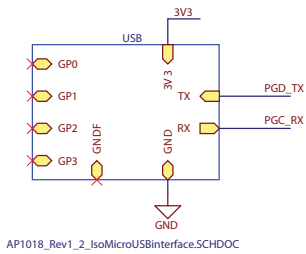

Figure 17: EPC9533 power circuit schematic

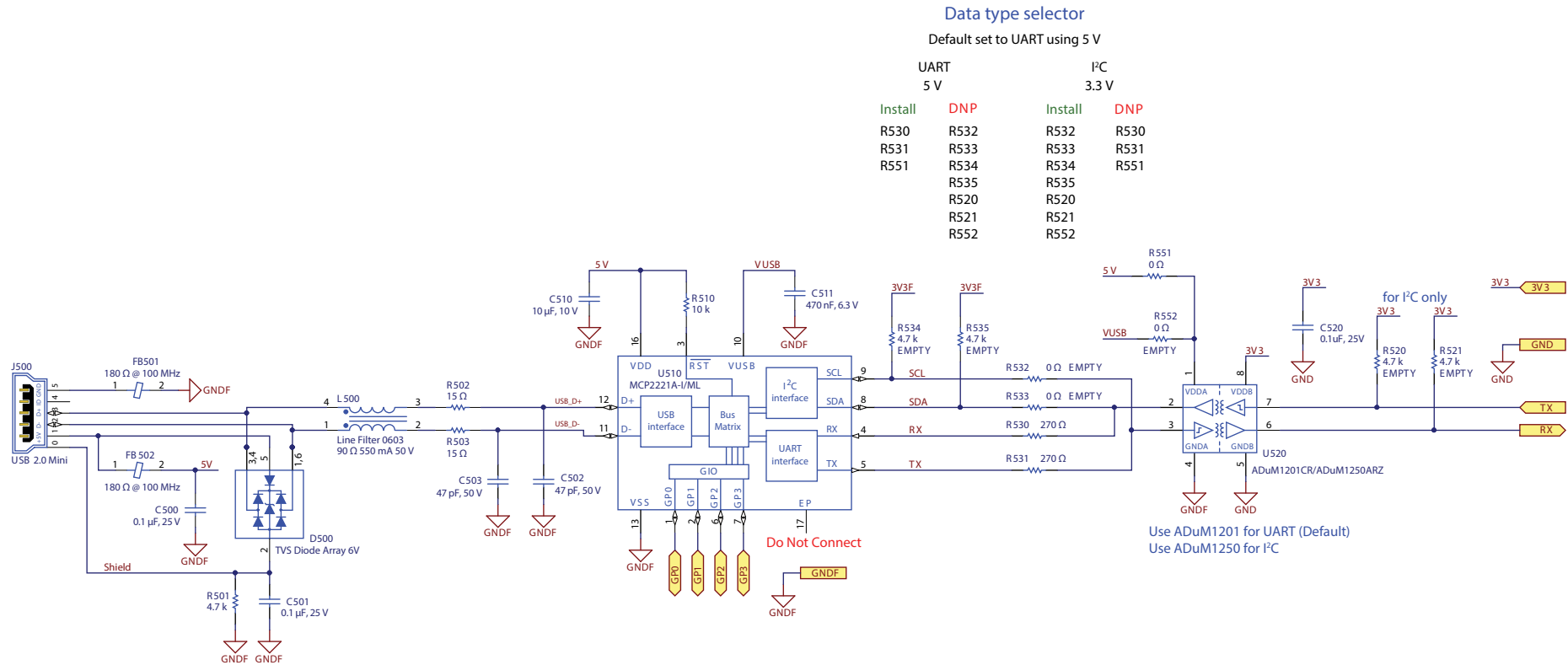

Figure 18: Isolated USB circuit on the EPC9533 motherboard



EPC would like to acknowledge Microchip Technology Inc. ([www.microchip.com](http://www.microchip.com)) for their support of this project.

Microchip Technology Incorporated is a leading provider of smart, connected and secure embedded control solutions. Its easy-to-use development tools and comprehensive product portfolio enable customers to create optimal designs, which reduce risk while lowering total system cost and time to market. The company's solutions serve customers across the industrial, automotive, consumer, aerospace and defense, communications and computing markets.

The EPC9149 system features the [dsPIC33CK32MP102](#) 16-Bit Digital Signal Controller with High-Speed ADC, Op Amps, Comparators and High-Resolution PWM. Learn more at [www.microchip.com](http://www.microchip.com).

## For More Information:

Please contact [info@epc-co.com](mailto:info@epc-co.com)  
or your local sales representative

Visit our website:  
[www.epc-co.com](http://www.epc-co.com)

Sign-up to receive  
EPC updates at  
[bit.ly/EPCupdates](http://bit.ly/EPCupdates)  
or text "EPC" to 22828



EPC Products are distributed through Digi-Key.  
[www.digikey.com](http://www.digikey.com)

### Demonstration Board Notification

**The EPC9149 board is intended for product evaluation purposes only. It is not intended for commercial use nor is it FCC approved for resale.** Replace components on the Evaluation Board only with those parts shown on the parts list (or Bill of Materials) in the Quick Start Guide. Contact an authorized EPC representative with any questions. This board is intended to be used by certified professionals, in a lab environment, following proper safety procedures. Use at your own risk.

As an evaluation tool, this board is not designed for compliance with the European Union directive on electromagnetic compatibility or any other such directives or regulations. As board builds are at times subject to product availability, it is possible that boards may contain components or assembly materials that are not RoHS compliant. Efficient Power Conversion Corporation (EPC) makes no guarantee that the purchased board is 100% RoHS compliant.

The Evaluation board (or kit) is for demonstration purposes only and neither the Board nor this Quick Start Guide constitute a sales contract or create any kind of warranty, whether express or implied, as to the applications or products involved.

Disclaimer: EPC reserves the right at any time, without notice, to make changes to any products described herein to improve reliability, function, or design. EPC does not assume any liability arising out of the application or use of any product or circuit described herein; neither does it convey any license under its patent rights, or other intellectual property whatsoever, nor the rights of others.