

SEATING TOOL KIT	SFP PRODUCT		
	CONFIGURATION	DESCRIPTION	APPLICATION SPECIFICATION
1725609-3*	1 x 2	Cage Assembly Using Surface Mount Connector (Supplied as Separate Parts)	114-13120
1725609-1*	1 x 4		
1725609-2*	1 x 6		
1490197-2	2 x 1	Standard Profile Cage Assembly With Press-Fit Connector (Supplied as One Unit)	114-13103
1490197-1	2 x 4		
1804875-1	2 x 6		
1725616-1	2 x 1	Low-Profile Cage Assembly With Press-Fit Connector (Supplied as One Unit)	114-13103
1725618-1	2 x 4		
1804419-1	2 x 6		
2018887-1	1 x 4	Cage Assembly W/Heat Sinks Using Surface Mount Connector (Supplied as One Unit)	114-13120
2018887-2	1 x 6		
2018887-3	1 x 2		
1725761-1	1 x 4	Cage Assembly with Press-Fit Connector (Supplied as one Unit)	114-13121
1725761-2	1 x 6		

*These seating tool kits cannot be used to seat the connector or single port cage assembly.

Figure 1

1. INTRODUCTION

SFP cage assembly seating tool kits listed in Figure 1 are used to seat SFP products described in Figure 1 onto the pc board. The cage assemblies and press-fit connectors contain compliant pin contacts to allow solderless pc board installation. Read these instructions thoroughly before using the seating tool kit.

i NOTE
 Dimensions on this sheet are in metric units [with U.S. customary units in brackets]. Figures are not drawn to scale.

Reasons for reissue are provided in Section 8, REVISION SUMMARY.

2. DESCRIPTION (See Figure 1)

Each seating tool kit consists of a seating tool and a wall support. The seating tool and wall support are also available separately. The seating tool has cutouts (two located on each side) to accept the protruding part of the standoffs of the cage assembly. The wall support must be installed into the port(s) of the cage assembly.

The top of the seating tool provides a surface to accept the force applied by the application tool to seat the product onto the pc board. During seating, the back and sides of the seating tool protect the cage assembly from damage. The wall support supports the individual port(s) of the cage assembly.

3. REQUIREMENTS

3.1. PC Board Support Fixture (Customer Supplied)

A pc board support must be used to provide proper support for the pc board and to protect the pc board and product from damage. The support fixture must be designed for specific needs using the following recommendations:

- it should be at least 25.4 mm [1 in.] longer and wider than the pc board
- it should have flat surfaces with holes or a channel large enough and deep enough to receive any protruding components of the product

3.2. Application Tool

Power for seating tools must be provided by an application tool (with a ram) capable of supplying a downward force of 44.5 N [10 lb-force] per contact. For available application tools, call PRODUCT INFORMATION at the number at the bottom of page 1.



CAUTION

Over-driving of the product will deform parts critical to the quality of the connection. Maximum force occurs prior to the product bottoming on the pc board.

4. SETUP

When setting up equipment to seat the product, pay particular attention to the following:

- the seating tool must be matched to the product



CAUTION

If the seating tool and product are mismatched or are improperly aligned, damage could occur to the tooling, product, or both.

- the wall support must be properly installed, and the seating tool, product, and application tool ram must be properly aligned before cycling the application tool
1. Set tool seating height to the dimension shown in Figure 2 (application tool *shut height* will equal the tool seating height PLUS the combined thicknesses of the pc board and support fixture). After seating, a gap of no more than 0.10 mm [.004 in.] between the cage assembly standoffs and the pc board is allowed.



NOTE

Use the tool seating height as a reference starting point. This height may need to be adjusted to obtain the amount allowed (maximum of 0.10 mm [.004 in.]) between the standoffs of the cage assembly and the pc board.

2. Slide the wall support into the port(s) of the cage assembly until the wall support is secure.

5. SEATING (Figure 2)



NOTE

For a cage assembly using a surface mount connector, the connector must be mounted on the pc board BEFORE seating the cage assembly.

1. Place the pc board on the support fixture.
2. Orient the seating tool over the product so that the back is aligned with the back of the product. Then lower the seating tool onto the product, making sure that the cutouts slide over the protruding components of the product, until the seating tool bottoms on the top of the product.

3. Place the product on the pc board so that the contacts and alignment posts are aligned and started into the matching holes in the pc board.
4. Center the seating tool (with the product) under the ram of the application tool. Slowly lower the ram until it just meets the seating tool. Verify alignment of pc board support, pc board, product, and seating tool.



CAUTION

Damage to the pc board, seating tool, or product may occur if the seating tool is not properly seated on the product before cycling the application tool.

5. Cycle the application tool to seat the product on the pc board. Then retract the ram, and carefully remove the seating tool by pulling it straight from the product.

NOTE: Not to scale

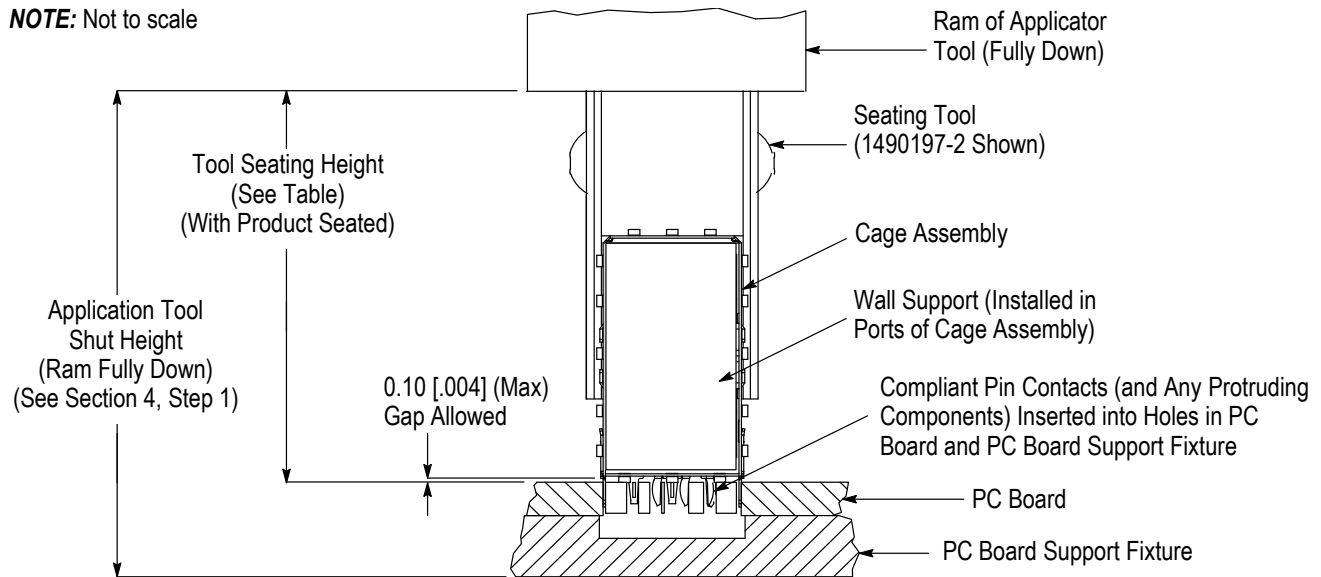

SFP PRODUCT		SEATING HEIGHT (mm [in.])	
CONFIGURATION	PROFILE	TOOL	PRODUCT
1 x 2, 1 x 4, 1 x 6	---	38.61 [1.52]	9.7 [.382]
2 x 1, 2 x 4, 2 x 6	Standard	40.64 [1.60]	25.5 [1.004]
	Low	37.59 [1.48]	22.55 [.888]

Figure 2

6. Check the product for proper seating according to the following:
 - a. the widest section of each compliant pin is inside its intended pc board hole
 - b. each alignment post is in its intended pc board hole
 - c. the product is seated on the pc board with a seating height-measured from the top of the product (not including the panel ground springs) to the top of the pc board-given in Figure 2
 - d. if present, the gap between the standoffs and the pc board is no more than 0.10 mm [.004 in.]



NOTE

For detailed application requirements of the product, refer to the relative application specification listed in Figure 1.

6. MAINTENANCE AND INSPECTION

The seating tool is assembled and inspected before shipment. It is recommended that the seating tool be inspected immediately upon arrival at your facility to ensure that it has not been damaged during shipment, and that it conforms to the dimensions provided in Figure 3.

6.1. Daily Maintenance

It is recommended that each operator be made aware of, and responsible for, the following steps of daily maintenance.

1. Remove dust, moisture, and contaminants with a clean, soft brush or a lint-free cloth. DO NOT use objects that could damage the components.
2. When the seating tool and wall support are not in use, store them in a clean, dry area.

6.2. Periodic Inspection

Regular inspections should be performed by quality control personnel. A record of scheduled inspections should remain with the seating tool or be supplied to personnel responsible for the seating tool kit. Inspection frequency should be based on amount of use, working conditions, operator training and skill, and established standards.

7. REPLACEMENT AND REPAIR

Customer-replaceable parts are listed in Figure 3.

A complete inventory should be stocked and controlled to prevent lost time when replacement of parts is necessary. Parts other than those listed should be replaced by TE Connectivity to ensure quality and reliability. Order replacement parts through your TE Representative, or call 1-800-522-6752, or send a facsimile of your purchase order to 717-986-7605, or write to:

CUSTOMER SERVICE (038-035)
TYCO ELECTRONICS CORPORATION
PO BOX 3608
HARRISBURG PA 17105-3608

8. REVISION SUMMARY

Revisions to this instruction sheet include:

- Updated document to corporate requirements
- Added new seating tool kits to table in Figures 1, 2, and 3

Kits 1725609-[] and 2018002-6

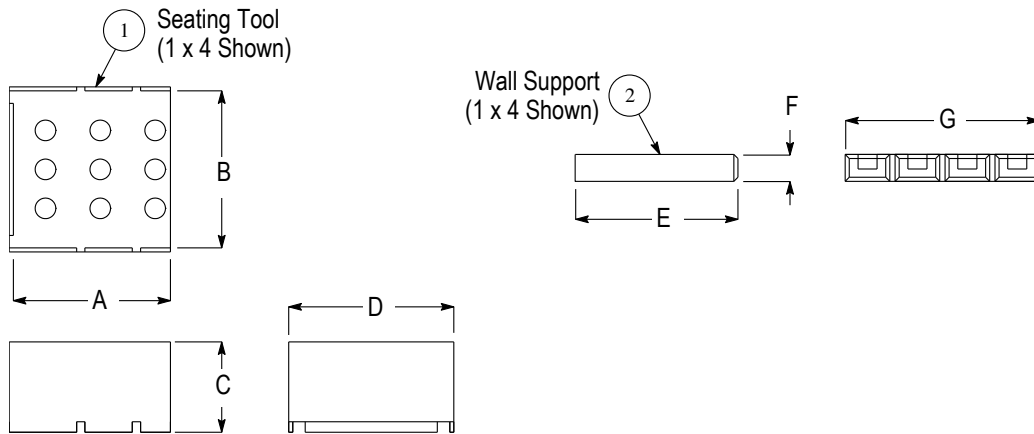

REPLACEMENT PARTS

ITEM	PART NUMBER FOR KIT (By Product Configuration)					
	1 X 2	1 X 4	1 X 6	1 X 4	1 X 6	QTY PER KIT
1	1725608-3	1725608-1	1725608-2	1725761-1	1725761-2	1
2	1725606-3	1725606-1	1725606-2	1725606-1	1725606-2	1

KIT (By Product Configuration)	DIMENSION (mm [in.])						
	A	B	C	D	E	F	G
1 x 2 (Kit 1725609-3)	43.43 [1.710]	14.73 [.580]	33.02 [1.300]	17.78 [.700]	50.8 [2.00]	8.38 [.330]	27.94 [1.100]
1 x 4 (Kit 1725609-1)	43.43 [1.710]	57.40 [2.260]	33.02 [1.300]	60.45 [2.380]	50.8 [2.00]	8.38 [.330]	55.88 [2.200]
1 x 6 (Kit 1725609-2)	43.43 [1.710]	86.10 [3.390]	33.02 [1.300]	88.9 [3.50]	50.8 [2.00]	8.38 [.330]	84.33 [3.320]
1 x 4 (Kit 1725761-1)	57.40 [2.26]	57.40 [2.26]	33.02 [1.300]	60.45 [2.380]	50.8 [2.00]	8.38 [.330]	55.88 [2.200]
1 x 6 (Kit 1725761-2)	57.40 [2.26]	86.10 [3.39]	33.02 [1.300]	88.9 [3.50]	50.8 [2.00]	8.38 [.330]	84.33 [3.320]

WALL SUPPORTS FOR CAGED ASSEMBLIES WITH HEAT SINKS

PRODUCT CONFIGURATION	PART NUMBER	E	F	G
1 x 4	2018887-1	50.8 [2.00]	8.38 [.330]	56.39 [2.220]
1 x 6	2018887-2	50.8 [2.00]	8.38 [.330]	84.33 [3.320]
1 x 2	2018887-3	50.8 [2.00]	8.38 [.330]	27.94 [1.100]

Figure 3 (cont'd)

Kits 1490197-[], 1725616-1, 1725618-1, 1804875-1, and 1804419-1

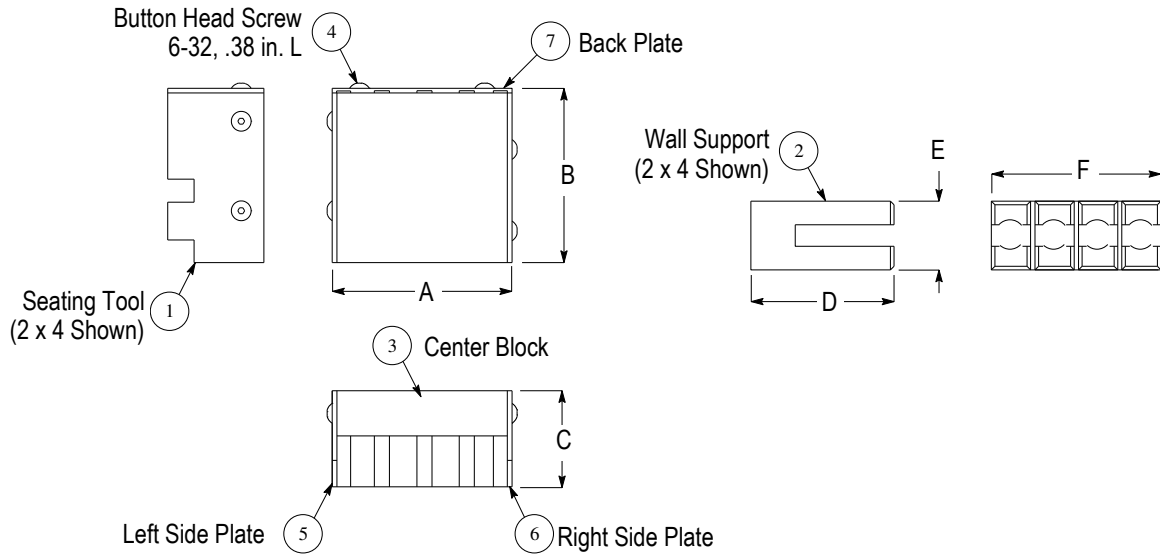

REPLACEMENT PARTS

ITEM	SFP PRODUCT PROFILE	PART NUMBER FOR KIT (By Product Configuration)			QTY PER KIT
		2 x 1	2 x 4	2 x 6	
1	Standard & Low	1725182-2	1725182-1	1804874-1	1
2	Standard	1725407-1	1725543-1	1804873-1	1
	Low	1725615-1	1725617-1	1804417-1	1
3	Standard & Low	1725193-1	1725183-1	1804876-1	1
4	Standard & Low	1-21002-7	1-21002-7	1-21002-7	6
5	Standard & Low	1725186-1	1725186-1	1725186-1	1
6	Standard & Low	1725185-1	1725185-1	1725185-1	1
7	Standard & Low	1725192-1	1725184-1	1804877-1	1

KIT (By Product Configuration)	SFP PRODUCT PROFILE	DIMENSION (mm [in.])					
		A	B	C	D	E	F
2 x 1	Standard	18.03 [.710]	58.67 [2.310]	32.51 [1.280]	50.8 [2.00]	24.38 [.960]	12.95 [.510]
	Low					21.34 [.840]	
2 x 4	Standard	60.45 [2.380]	58.67 [2.310]	32.51 [1.280]	50.8 [2.00]	24.38 [.960]	56.39 [2.220]
	Low					21.34 [.840]	
2 x 6	Standard	89.15 [3.510]	58.67 [2.310]	32.51 [1.280]	50.8 [2.00]	24.38 [.960]	84.33 [3.320]
	Low					21.34 [.840]	

Figure 3 (end)