

Tous droits strictement reserves. Reproduction ou communication a des tiers interdite sous quelque forme que ce soit sans autorisation écrite du propriétaire. Propriete de c fci. Droits de reproduction FCI.

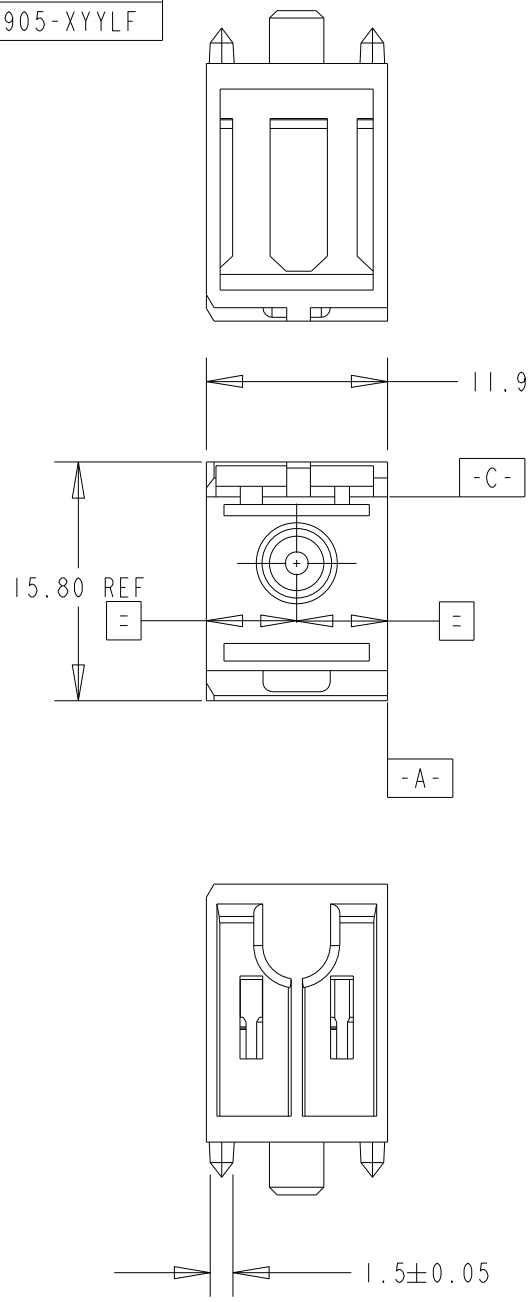

All rights strictly reserved. Reproduction or issue to third parties in any form whatever is not permitted without written authority from the proprietor. Property of FCI. Copyright FCI.

PRODUCT NUMBER
10051905-XY
10051905-XYLFL



P/N	DIMENSION				TERMINAL	HOUSING
	DIM A	DIM B	DIM C	DIM D		
10051905-101	Ø 3.60	8.10 <sup>+0.15</sup>	Ø 3.60	3.50	10051444-X01LF	88911-101
10051905-101LF						

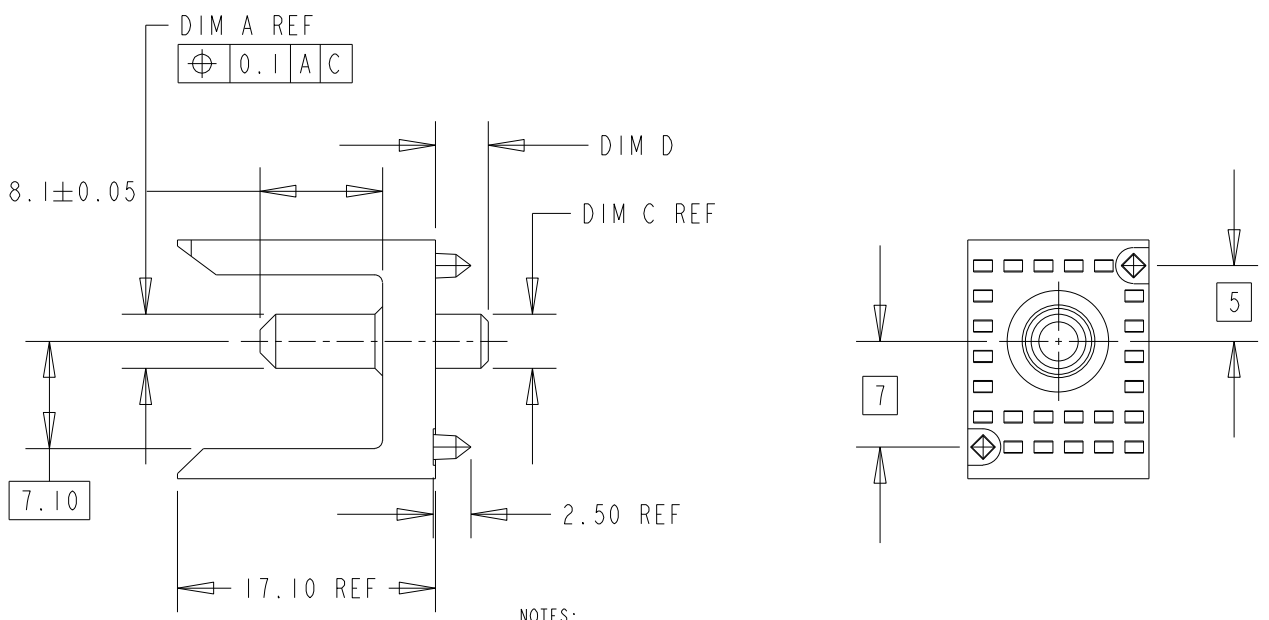

- NOTES:
- "X" INDICATES PLATING INFORMATION IN BOTH TERMINAL AND ASSEMBLY PART NUMBER.
  - MARKING:  
FOR METRAL & P/N SEE DRAWING 59550.
  - PACKAGING: GS-14-1013
  - SEE "KEY" FOR CONTACT CODE CROSS REFERENCE INFORMATION.
  - THIS PRODUCT MEET EUROPEAN UNION DIRECTIVES AND OTHER COUNTRY REGULATIONS AS DESCRIBED IN GS-22-008.
  - THE HOUSING WILL WITHSTAND EXPOSURE TO 260° PEAK TEMPERATURE FOR 10 SECOND IN A WAVE SOLDER APPLICATION.

rev	ecn no	dr	date
A	DG05-0014	LHS	01/24/05
B	DG05-0226	CLU	07/15/05
-	-	-	-
-	-	-	-
-	-	-	-
-	-	-	-

Material		Spec ref		
Mat code		tolerance	projection	MM
Heattreat		XX ±.3	⊕	
Plating/Finish		XX ±.13		
Dr	Collins Lu	05/27/05	size	A4
Eng	Collins Lu	05/28/05	Product family	Scale
Chr	Victor Lin	05/30/05	Model Name	10051905
Appr	Joseph Hsia	05/30/05	Model Revision	ECN
			REL Level	released
<b>A</b>	title	STR POWER HEADER ASS'Y		Rev.
<b>FCI</b>		dwg no	10051905	B
Pro/E file	catalog no	CUSTOMER	sheet 1 of 2	

Tous droits strictement réservés. Reproduction ou communication à des tiers interdite sous quelque forme que ce soit sans autorisation écrite du propriétaire. Propriété de FCI. Droits de reproduction FCI.

**A**  
FCI

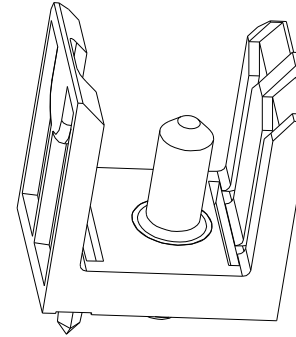
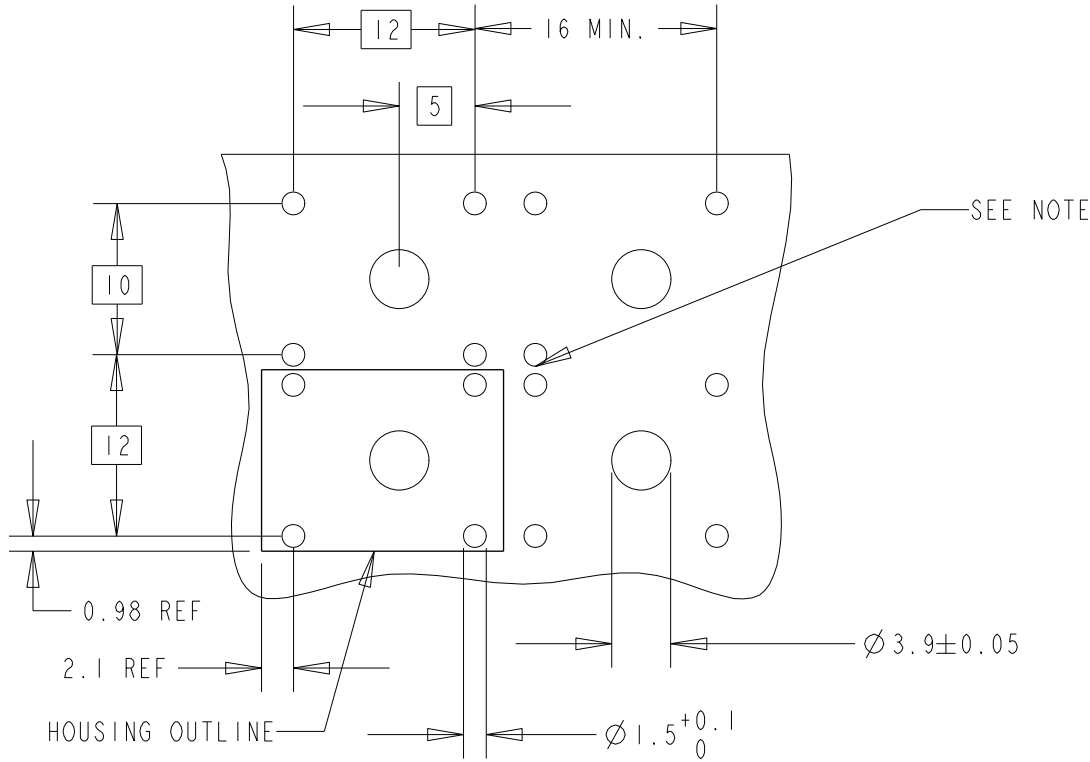

RECOMMENDED HOLE PATTERN COMPONENT SIDE

SCALE 2.000

All rights strictly reserved. Reproduction or issue to third parties in any form whatever is not permitted without written authority from the proprietor. Property of FCI. Copyright FCI.

rev	ecn no	dr	date
-	-	-	-
-	-	-	-
-	-	-	-
-	-	-	-
-	-	-	-
-	-	-	-
-	-	-	-

Material			Spec ref		
Mat code			tolerance	projection	MM
Heattreat					
Plating/Finish			size	A4	Scale
Dr	05/29/05	14-Jun-05			
Eng	Collins Lu	05/29/05	Product family		
Chr	Victor Lin	05/30/05	Model Name	10051905	ECBCN DG05-0014
Appr	Joseph Hsia	05/30/05	Model Revision	REL Level released	
<b>A</b> FCI		title		dwg no	10051905
Pro/E file		catalog no		CUSTOMER	Rev. B
				sheet 2 of 2	