

SIDE VIEW FOR EACH VERSION

UTSX7-----PSCR

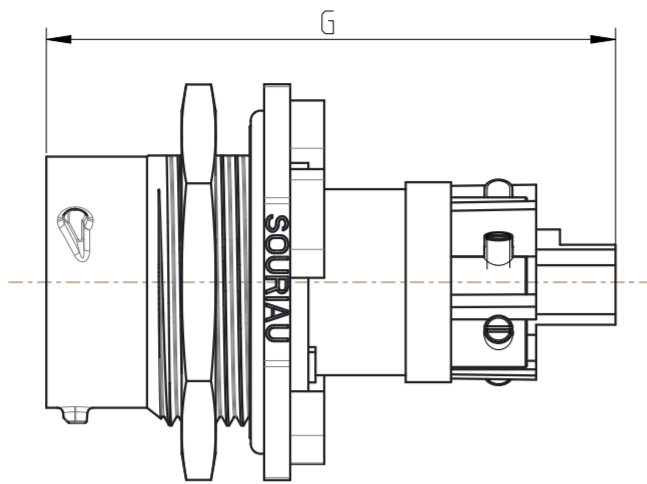

UTSX7-----SSCR

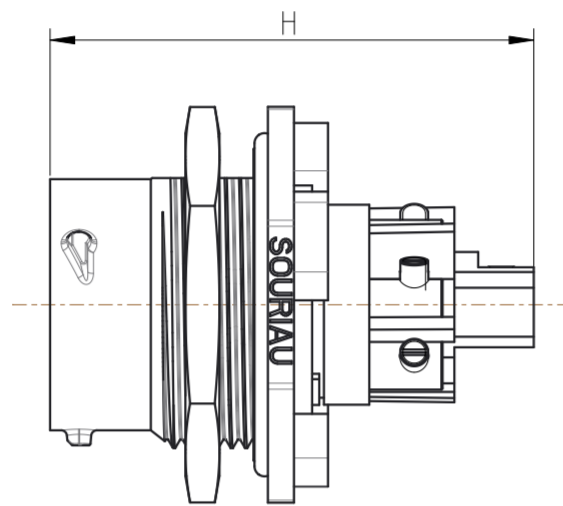

SEALING CONDITION

Sealing in MATED conditions with COUNTERPART:
 -IP6x : No ingress of dust
 -IPx8 1 bar during 1 week: immersion under 10 m of water.
 -IPx9K : exposure to high pressure water of cleaning equipment (IEC 60529)

PANEL CUT OUT

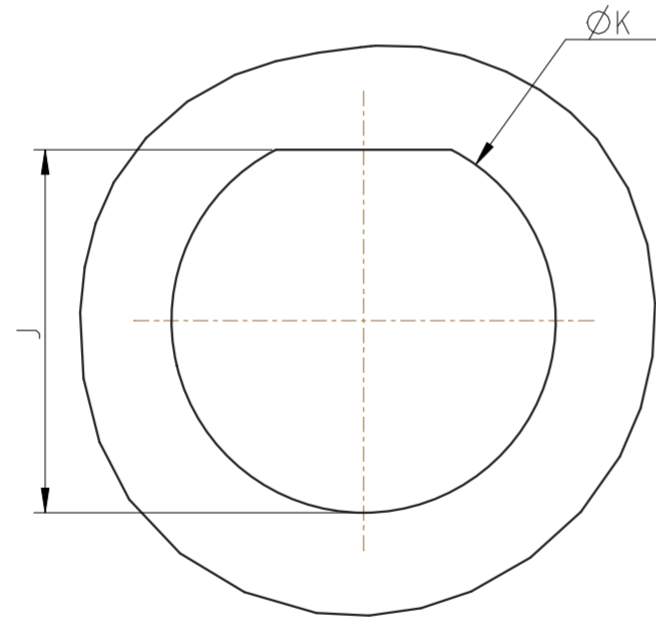

PANEL THICKNESS

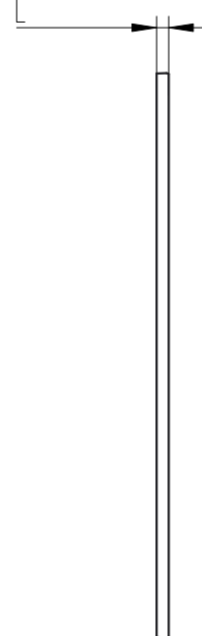

COMMON QUOTES FOR ALL VERSION

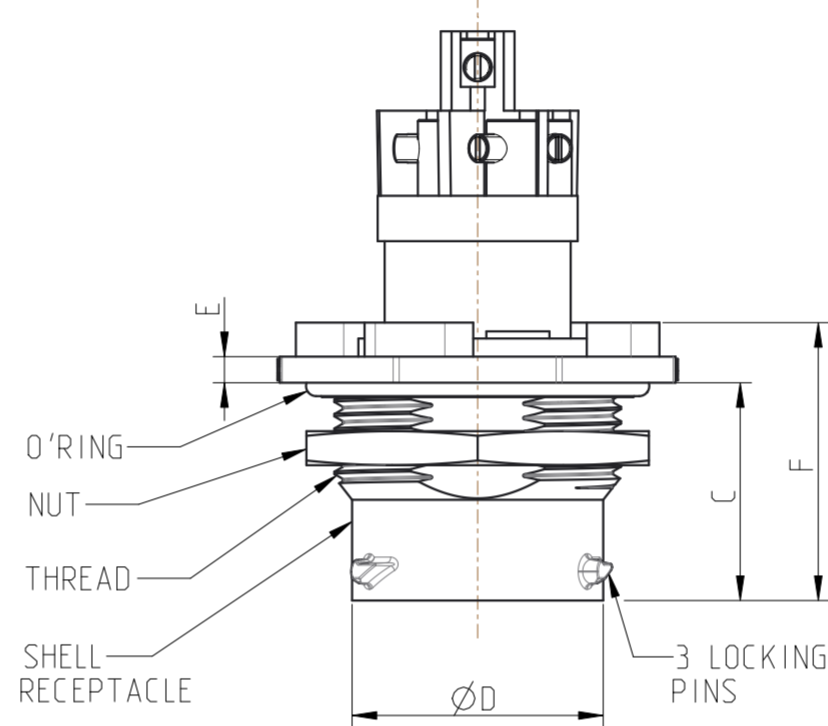
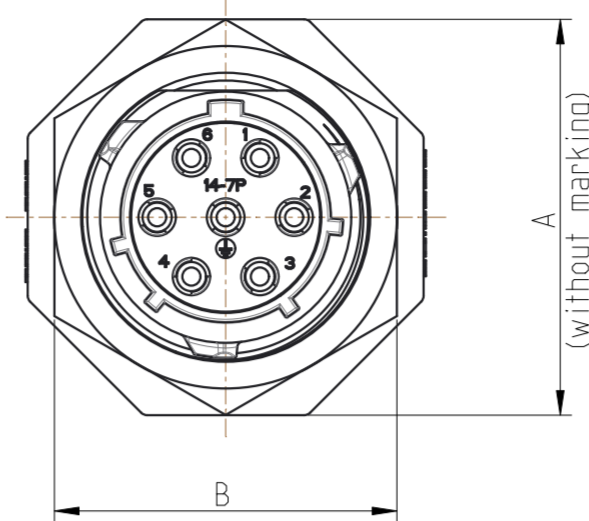

MATERIAL :

- SHELL : PA UL94 V0, UL746C F1 Black color
- INSERT : PA UL94 V0, UL746C F1
- NUT : Aluminium alloy + Anodic oxidation
- O'RING : Nitril
- CONTACT SPRING: copper alloy
- CONTACT BODY : brass, gold and nickel plated
- SCREW : stainless steel

PERFORMANCE CHARACTERISTICS :

Operating temperature: -40°C up to 105°C
 Insulation resistance: 5000 MΩmin
 Corrosion salt spray: 500 hours
 Durability: 250 matings and unmatings
 Sealing conditions: SEE TABLE

NOTA:

- 1- Contact to be ordered separately for version UTSX7----- : refer to corresponding catalogue.
- 2- Insert arrangement refer to:
 UTX_LAYOUT (Standard Version)
 Only for layout 12-4 and 14-7

Country	Jurisdiction & Control List
FR	NOT LISTED

SOURIAU shall not be liable for any non-conformity or damage due to a use of the Products which does not comply with the Specifications issued by either of the Parties or by a third party (professional recommendation, technical notice.)

P/N : CROSS REF TABLE

BASIC SERIES	UTSX	7	14	7	P	SCR	*P/N for example
SHELL TYPE	7	Jam nut receptacle					
SHELL SIZE	12	14					
INSERT ARRANGEMENT	See NOTA 2						
SCREW TERMINATION						TYPE OF CONTACTS	
						P: MALE S: FEMALE	

SHELL SIZE	±0.2	±0.2	±0.3	±0.2	±0.3	±0.2	MAX	MAX	±0.2	±0.15	±2	UNEFC CLASS 2A
	A	B	C	ØD	E	F	G	H	J	ØK	L	THREAD
12	31.75	27.15	19.3	19.15	2.2	24.5	46.5	38.3	21.4	22.7	3	7/8 20
14	34.90	30.20		22.31			52.5	44.4	24.5	25.9		1"20

DETAIL CONTACT

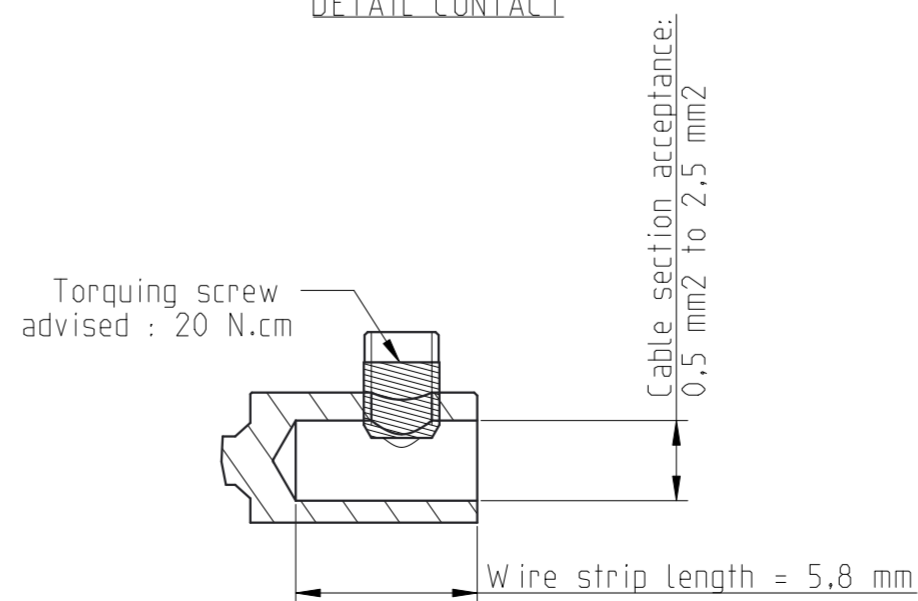

B	15/09/2021	Mass column deleted	25782C
ISS	DATE	Latest modification - by:	Q.LECOMTE
Designed by:		J.GAMBIER	Date: 1 02/11/2020

TITLE		JAM NUT RECEPTACLE WITH SCREW CONTACT- SIZE 12 & 14	
Scale		3/1	
Dimensions in mm		General Linear Tolerances: ± 0.2	
FORMAT		A2	

NPRDS / PROJECT		GBB	
www.souriau.com		This document is the property of SOURIAU. It must not be reproduced or communicated without permission.	
SOURIAU DRG N°		UTSX-0007A-C	
SHEET		1 / 1	