

DEB71



Earth Leakage Monitoring Relay



Benefits

- **Adjustable trip level.** Adjustable leakage threshold from 30mA to 5A or from 300mA to 30A.
- **2 outputs.** Two relay outputs provide, besides the alarm signal an additional warning output.
- **Level indication.** LED Bar shows at a glance the real time leakage level.
- **Nuisance tripping safe.** EN 60947-2 Annex M conformity.
- **Anti tampering.** Sealable front lid provides protection against possible tampering.
- **Remote R/T button.** Input for external reset switch allows remote system restart in case of tripping.
- **Single / Threephase mains.** The DEB71 can be used on both three phase or single phase.

Description

The DEB71 is an adjustable modular residual current relay which, in conjunction with the MCB and the CT, provides protection against possible risks arising from insulation or grounding faults, by interrupting the mains on faulty loads or lines.

The setpoint of the leakage current is adjustable. The device is equipped with two changeover relay outputs.

One output triggers at 60% of fault current setpoint value providing a warning to user, the other output is used to shut down the system to prevent accidents.

Applications

The DEB is a flexible device and can be used for all the applications where the loss of insulation, and/or grounding failure, could lead to severe consequences.

Structure

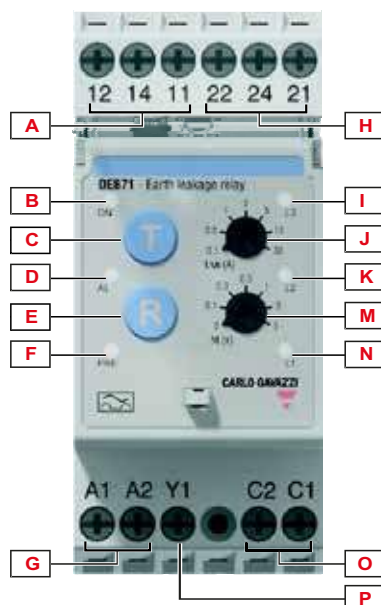

Element	Component	Function
A	Output 1	Main alarm SPDT relay output: 11 C, 12 NC, 14 NO
B	LED ON	Power ON GREEN LED
C	Test pushbutton	When pressed it will test the system integrity
D	LED AL	Alarm RED LED. It turns ON when current exceeds 80% of $I_{\Delta n}$
E	Reset pushbutton	Restores operation after an alarm has been triggered
F	LED PRE	Warning YELLOW LED. Lit when leakage level exceeds 60% of set $I_{\Delta n}$
G	Power supply terminals	Power supply from 24VAC to 240VAC
H	Output 2	Warning alarm output: 21 C, 22 NC, 24 NO
I	LED L3	$\geq 60\% I_{\Delta n}$ LED Bar
J	Alarm set	$I_{\Delta n}$ current alarm threshold setting
K	LED L2	$\geq 40\% I_{\Delta n}$ LED Bar
M	Delay set	Δt alarm delay setting from 0 to 5s
N	LED L1	$\geq 20\% I_{\Delta n}$ LED Bar
O	Sensor input	Input for external Core Balance Transformer (CTG)
P	Remote R/T	Input for remote R / T pushbutton (in conjunction with A2)

Features

General

Material	PA66 or Noryl
Colour	RAL7035 (light grey)
Front cover material	Transparent polycarbonate
Sealing / locking	Sealing slot
Mechanical form type	According to DIN 43880
Assembly	DIN rail mounting (according to EN 50022)
Protection degree	IP20
Weight	150 g
Terminals	Screw terminals. Cable size AWG30 to AWG12 (0.06 mm ² to 3.3 mm ²) stranded or solid
Tightening torque	0.4Nm to 0.8Nm (from 4lb-in to 7lb-in)

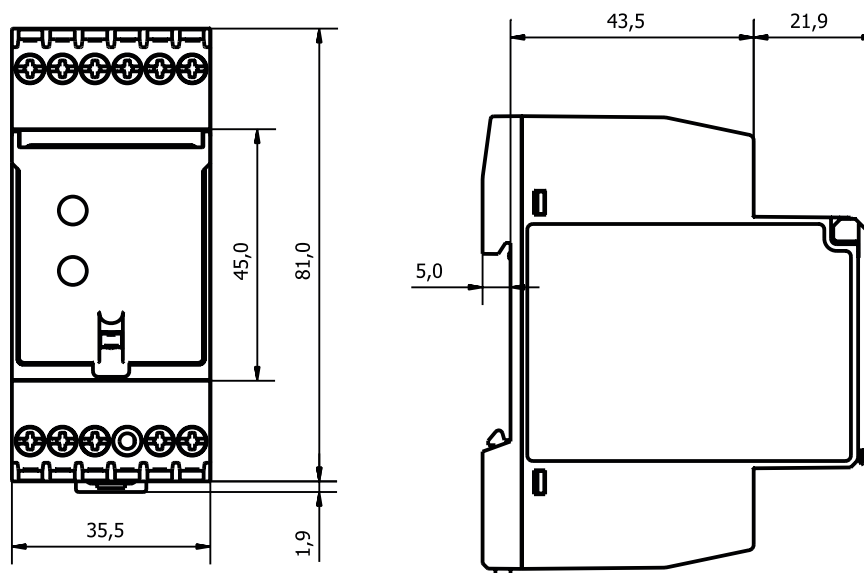

Power supply

Auxiliary power supply	24 to 240 Vac \pm 10%
Frequency	50 to 60 Hz \pm 10%
Consumption	< 2.5 VA
Overvoltage category	III

Environmental

Working temperature	-25° C to 60° C (-13° F to 140° F)
Storage temperature	-40° C to 80° C (-40° F to 176° F)
Relative humidity	5-95% non condensing
Pollution degree	2
Operating max altitude	2000 m amsl (6560ft)
Salinity	No saline environment
UV resistance	No UV exposure

Vibration/Shock resistance

Test condition	Test	Level
Tests with the device outside the box	Vibration response (IEC60255-21-1)	Class 1
	Vibration endurance (IEC 60255-21-1)	Class 1
	Shock (IEC 60255-21-2)	Class 1
	Bump (IEC 60255-21-2)	Class 1
Tests with the device inside the box	Vibration random (IEC60068-2-64)	Class 1
	Shock (IEC 60255-21-2)	Class 1
	Bump (IEC 60255-21-2)	Class 1

Class 1: normal use in industrial plants, normal transportation conditions.

Compatibility and conformity

CE-marking	Complies to European LV directive 2014/35/EU and EMC directive 2014/30/EU EN 60947-2 Annex M, EN 62020
Approvals	 UL508, CSA Standard C22.2 No. 14-10 – Industrial control equipment, RoHS Directive
Other standards	IEC TR 60755

Inputs

Current measuring input

Typology	Residual current measuring from Core Balance Transformer (CBT)
Type	A
CBT type	Only Carlo Gavazzi CTG family types can be used. Select model according to mains cable diameter
Measuring ranges (IΔn)	See the table below
Warning threshold	60% I Δ n
Alarm threshold	80% I Δ n
Current overloads (continuous)	See the table below
Resolution (% of the selected IΔn)	2%
Accuracy (% of the selected IΔn)	10%
Repeatability (% of the selected IΔn)	2%
Alarm delay setting Δt	0, 0.1s, 0.3s, 0.5s, 1s, 3s, 5s On DEB71DM24A5 when 30mA I Δ n is selected, the time is forced to 0 in order to comply with EN 60947-2



Code	Measuring ranges (IΔn)	Current overloads (continuous)
DEB71DM24A5	30 mA	150 mA
	100 mA	500 mA
	300 mA	1500 mA
	500 mA	2.5 A
	1 A	5 A
	2 A	10 A
	5 A	10 A
DEB71DM24A30	300 mA	1500 mA
	500 mA	2.5 A
	1 A	5 A
	2 A	10 A
	5 A	25 A
	10 A	30 A
	30 A	40 A

Remote Test/Reset input

Typology	Input for push-button on connectors Y1, A2
Logic levels	Open state: >100kOhm Closed state: <100Ohm
Refresh time	≤ 500ms

Outputs

Output 1	
Typology	Relay SPDT on contacts 11(C), 12(NC), 14(NO) ⁽¹⁾ AC1: 5 A @ 250 VAC ⁽²⁾ DC12: 5 A @ 24 VDC ⁽²⁾ AC15: 2.5 A @ 250 VAC DC13: 2.5 A @ 24 VDC
Electrical lifetime	10 ⁵ operations @ 250 VAC resistive load
Assignment	Associated to MAIN alarm
Logic	Energised when MAIN alarm OFF
Reaction time	215 ms with Δt 0 s (from CT variation detection to relay switching)
Output 2	
Typology	Relay SPDT on contacts 21(C), 22(NC), 24(NO) ⁽¹⁾ AC1: 5 A @ 250 VAC ⁽²⁾ DC12: 5 A @ 24 VDC ⁽²⁾ AC15: 2.5 A @ 250 VAC DC13: 2.5 A @ 24 VDC
Electrical life	10 ⁵ operations @ 250 VAC resistive load
Assignment	Associated to WARNING alarm
Logic	Energised when WARNING alarm OFF
Reaction time	215 ms with Δt 0 s (from CT variation detection to relay switching)

⁽¹⁾ Terminals are numbered, according to the EN60947-1, as fast acting even though they can be delayed by setting. Normally Open / Closed are intended when device is not powered.

⁽²⁾ 5A is actually the connector current limit.

Operating diagram

The DEB71 is a modular residual current device which is used to detect when a failure, of an electric circuit, causes a current leak to earth.

The mains cables are passed through an external CBCT (Core Balance Current Transformer), with the exception of the PE which has to be routed outside, as shown in the hereafter suggested connection diagram. Before starting the operation it is necessary to set the required leakage tripping current $I_{\Delta n}$, from 30mA to 5A (DEB71DM24A5) or from 300mA to 30A (DEB71DM24A30).

A delay up to 5s can also be set.

Once the setting is completed, the front lid can be closed and sealed to prevent tampering.

Normal operation

When the circuit is powered the green LED (ON) will turn ON. If the current flowing to the load/s through the lines is the same flowing back from the load/s, the resulting current on the CBCT output will be zero. All other LEDs are OFF, both output relays are energised, external MCB is closed.

Alarm detection

In case of leak on the load or lines, the amount of current flowing back from the load is less than the one provided. This unbalancement causes a current flow on the CBCT output. The current is proportional to the leakage current.

If the leakage is below 20% of the set leakage threshold $I_{\Delta n}$, no indication is provided. When the leakage exceeds 20% and is below 40% the green LED (L1) is lit. Above 40%, but still below 60%, the yellow LED (L2) is also lit. Above 60% L3 yellow LED is lit. At this level the warning signal goes off: LED "PRE" will light and output 2 relay is de-energised (terminal 21 closed on 22).

When the leakage rises above 80%, of the set threshold, ALARM goes off after Δt delay elapsing: red LED "AL" is lit, output 1 is de-energised (terminal 11 closed on 12). The external MCB will open, disconnecting the mains from the load/s.

Reset

When the fault cause has been eliminated, operation can be restored by pressing the R pushbutton on the device front panel or by pressing the remote R/T pushbutton.

Test

System integrity has to be periodically tested by pressing the T pushbutton on the device front panel. It is also possible by pressing the remote R/T pushbutton for more than 2s.

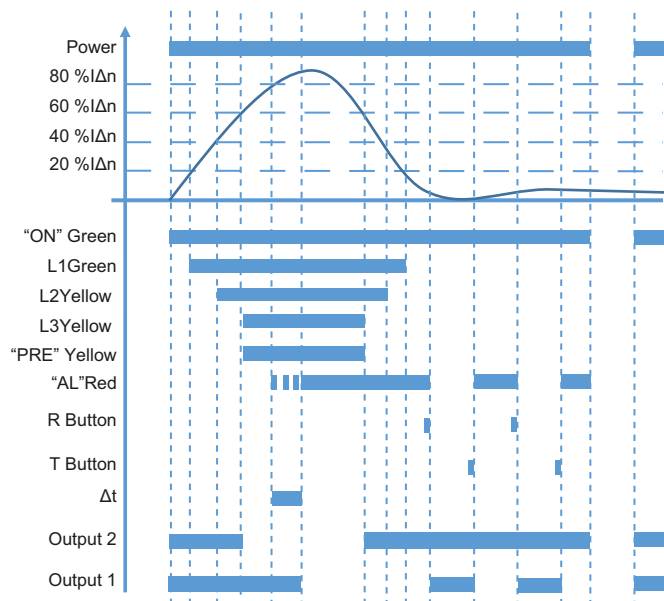

Connection Diagrams

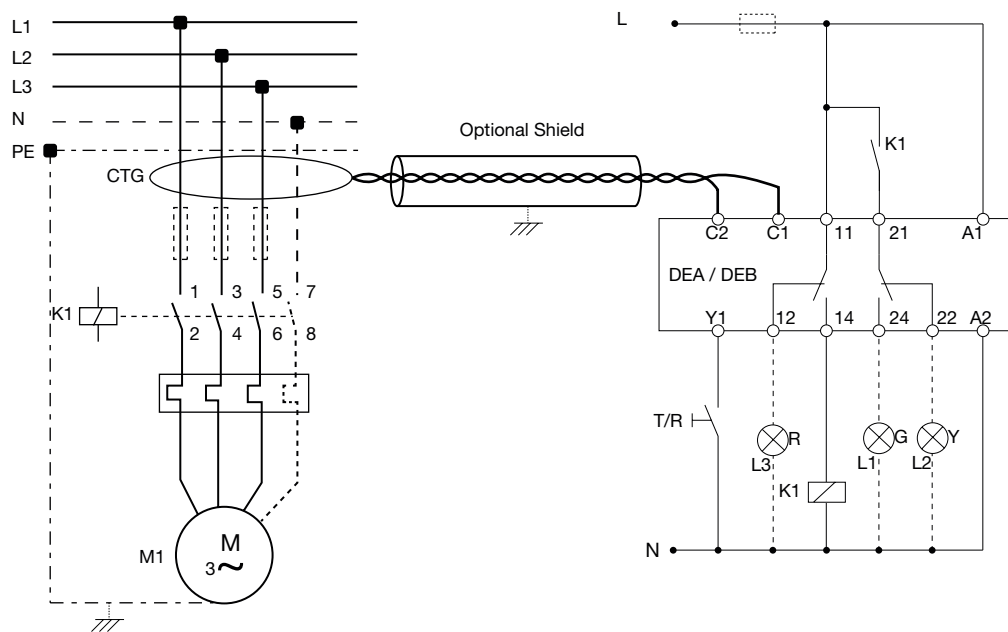

References

Order code



DEB71DM24A5

Adjustable current from 30mA to 5A



DEB71DM24A30

Adjustable current from 300mA to 30A

CARLO GAVAZZI compatible components

Purpose	Component name/code key	Notes
Core balance transformer, hole Ø 35 mm	CTG035	
Core balance transformer, hole Ø 50 mm	CTG050	
Core balance transformer, hole Ø 70 mm	CTG070	
Core balance transformer, hole Ø 120 mm	CTG120	
Core balance transformer, hole Ø 160 mm	CTG160	
Core balance transformer, hole Ø 210 mm	CTG210	

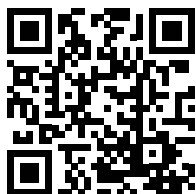

COPYRIGHT ©2016
Content subject to change. Download the PDF: www.productselection.net