

DESCRIPTION

These low capacitance diode arrays are multiple, discrete, isolated junctions fabricated by a planar process and mounted in a 14-PIN ceramic DIP package for use as steering diodes protecting up to eight I/O ports from ESD, EFT, or surge by directing them to the positive side of the power supply line and to ground (see Figure 1). An external TVS diode may be added between the positive supply line and ground to prevent over-voltage on the supply rail. They may also be used in fast switching core-driver applications. This includes computers and peripheral equipment such as magnetic cores, thin-film memories, plated-wire memories, etc., as well as decoding or encoding applications. These arrays offer many advantages of integrated circuits such as high-density packaging and improved reliability. This is a result of fewer pick and place operations, smaller footprint, smaller weight, and elimination of various discrete packages that may not be as user friendly in PC board mounting.

IMPORTANT: For the most current data, consult MICROSEMI's website: <http://www.microsemi.com>

APPEARANCE

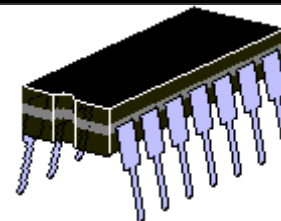

14-PIN Ceramic DIP

FEATURES

- Hermetic Ceramic Package
- Isolated Diodes to Eliminate Cross-Talk Voltages
- High Breakdown Voltage $V_{BR} > 60$ V at 10 μ A
- Low Leakage $I_R < 100$ nA at 40 V
- Low Capacitance $C < 8.0$ pF
- Switching Speeds less than 20 ns
- Options for screening in accordance with MIL-PRF-19500/474 for JAN, JANTX, JANTXV, and JANS are available by adding MQ, MX, MV, or MSP prefixes respectively to part numbers. For example, designate MX1N6508 for a JANTX screen.

MAXIMUM RATINGS

- Reverse Breakdown Voltage of 60 Vdc (Note 1 & 2)
- Continuous Forward Current of 300 mA dc (Note 1 & 3)
- Peak Surge Current ($t_p=1/120$ s) of 500 mA dc (Note 1)
- 400 mW Power Dissipation per Junction @ 25°C
- 600 mW Power Dissipation per Package @ 25°C (Note 4)
- Operating Junction Temperature range -65 to +150°C
- Storage Temperature range of -65 to +200°C

NOTE 1: Each Diode

NOTE 2: Pulsed: $P_w = 100$ ms max; duty cycle $\leq 20\%$

NOTE 3: Derate at 2.4 mA/°C above +25°C

NOTE 4: Derate at 4.8 mW/°C above +25°C

APPLICATIONS / BENEFITS

- High Frequency Data Lines
- RS-232 & RS-422 Interface Networks
- Ethernet: 10 Base T
- Computer I/O Ports
- LAN
- Switching Core Drivers
- IEC 61000-4 Compatible (see circuit in figure 1)
61000-4-2 ESD: Air 15 kV, contact 8 kW
61000-4-4 (EFT): 40 A - 5/50 ns
61000-4-5 (surge): 12 A 8/20 μ s

MECHANICAL AND PACKAGING

- 14-PIN Ceramic DIP
- Weight 2.05 grams (approximate)
- Marking: Logo, part number, date code
- Pin #1 to the left of the indent on top of package
- Carrier Tubes; 25 pcs (standard)

ELECTRICAL CHARACTERISTICS (Per Diode) @25°C unless otherwise specified

PART NUMBER	MAXIMUM FORWARD VOLTAGE V_{F1} $I_F = 100$ mA (Note 1)	MAXIMUM FORWARD VOLTAGE V_{F2} $I_F = 500$ mA (Note 1)	MAXIMUM REVERSE CURRENT I_{R1} $V_R = 40$ V	MAXIMUM CAPACITANCE (PIN TO PIN) C_t $V_R = 0$ V $F = 1$ MHz	MAXIMUM FORWARD RECOVERY TIME t_{fr} $I_F = 500$ mA	MAXIMUM REVERSE RECOVERY TIME t_{rr} $I_F = I_R = 200$ mA $i_{rr} = 20$ mA $R_L = 100$ ohms
	V	V	μ A	pF	ns	ns
1N6508	1	1.7	0.1	8.0	40	20

NOTE 1: Pulsed: $P_w = 300$ μ s +/- 50 μ s, duty cycle $\leq 2\%$, 90 μ s after leading edge.

SYMBOLS & DEFINITIONS

Symbol	DEFINITION
V_{BR}	Minimum Breakdown Voltage: The minimum voltage the device will exhibit at a specified current.
V_F	Maximum Forward Voltage: The maximum forward voltage the device will exhibit at a specified current.
I_R	Maximum Leakage Current: The maximum leakage current that will flow at the specified voltage and temperature.
C_t	Capacitance: The capacitance of the TVS as defined @ 0 volts at a frequency of 1 MHz and stated in picofarads.

SCHEMATIC

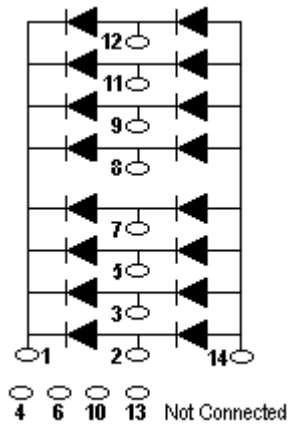

PACKAGE DIMENSIONS

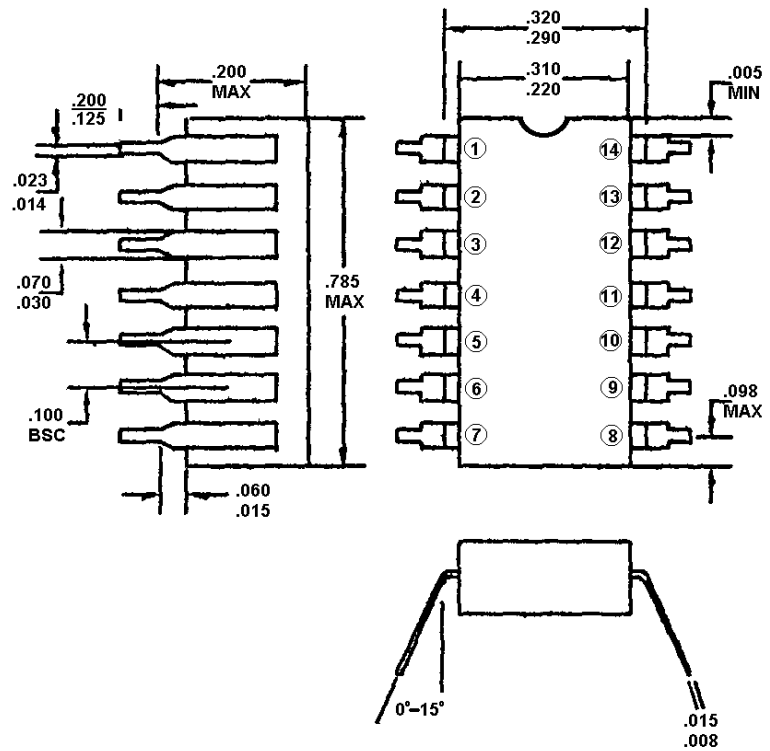

CIRCUIT

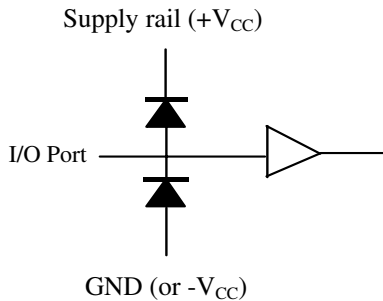

Steering Diode Application
FIGURE 1