

© 2008 Tyco Electronics. All rights reserved.

 <p><b>Raychem</b> Wire and Harnessing Products 300 Constitution Drive Menlo Park, CA 94025, USA</p>		TITLE: <b>HEXASHIELD ADAPTOR FOR                  CODE 54 CONNECTOR – O/NO 20                  PLAIN CLAMPING NUT</b>		
UNLESS OTHERWISE SPECIFIED DIMENSIONS ARE IN MILLIMETERS. INCH DIMENSIONS ARE SHOWN IN BRACKETS		Tyco Electronics reserves the right to amend this drawing at any time. Users should evaluate the suitability of the product for their application.		DOCUMENT NO. <b>HXS121-AY-90-21-A1-1</b>
DRAWN: IRT	DATE: JAN 08	CAGE CODE: 06090	DCR # ECO-08-019355	FILE: 87003/121
		SCALE: NONE	SHEET: 1 OF 3	

# CUSTOMER DRAWING

REV:  
ADATE:  
Aug 21, 2008

## KIT DESCRIPTION

ITEM	DESCRIPTION	MATERIAL
1	BODY ASSEMBLY	ALUMINIUM ALLOY
2	CLAMPING NUT – PLAIN	ALUMINIUM ALLOY
3	CONIC RING	ALUMINIUM ALLOY

## ORDER INFORMATION

Order Number	Shell Size		Ferrule Quantity (See Application)
	Type A	Type B	
21	20	37	1

## PART NUMBERING

HXS121 - A C - 90 - 21 - A1 - 1

- SEQUENTIAL NUMBER \_\_\_\_\_
- SEE APPLICATION FOR MATING INFORMATION
- MATERIAL CODE: \_\_\_\_\_
- A = ALUMINIUM ALLOY
- PLATING CODE: \_\_\_\_\_
- B = CADMIUM OLIVE DRAB TO SAE-AMS-QQ-P416
- C = ELECTROLESS NICKEL TO SAE-AMS-C-26074
- BODY STYLE \_\_\_\_\_
- 90 = 90°
- ORDER NUMBER \_\_\_\_\_
- FERRULE QUANTITY CODE – SEE APPLICATION \_\_\_\_\_
- 1 = PLAIN CLAMPING NUT \_\_\_\_\_

## APPLICATION

- This adaptor is designed to be mounted on the following connectors:

MIL-DTL-26482 Series II )  
MIL-DTL-83723 Series I and III ) Shell Size 20 Type A  
MIL-DTL-5015 )  
HE312 )

SAE-AS81703 Series III )  
HE312 ) Shell Size 37 Type B  
DBAD )

- It is qualified to the Raychem specification RB-114, when installed on metallic MIL-Specification circular connectors only.
  - It is designed primarily for open wire bundle installations but is also designed to accept Raychem heat shrink moulded
- © 2008 Tyco Electronics. All rights reserved.

 <b>Raychem</b> Wire and Harnessing Products 300 Constitution Drive Menlo Park, CA 94025, USA				TITLE: <b>HEXASHIELD ADAPTOR FOR CODE 54 CONNECTOR – O/NO 20 PLAIN CLAMPING NUT</b>			
UNLESS OTHERWISE SPECIFIED DIMENSIONS ARE IN MILLIMETERS. INCH DIMENSIONS ARE SHOWN IN BRACKETS				Tyco Electronics reserves the right to amend this drawing at any time. Users should evaluate the suitability of the product for their application.		DOCUMENT NO. <b>HXS121-AY-90-21-A1-1</b>	
DRAWN: IRT	DATE: JAN 08	CAGE CODE: 06090	DCR # ECO-08-019355	FILE: 87003/121	SCALE: NONE	SHEET: 2 OF 3	

If this document is printed it becomes uncontrolled. Check for the latest revision

# CUSTOMER DRAWING

REV:  
A

DATE:  
Aug 21, 2008

parts where strain relief and sealing is required – see illustration on sheet 3.

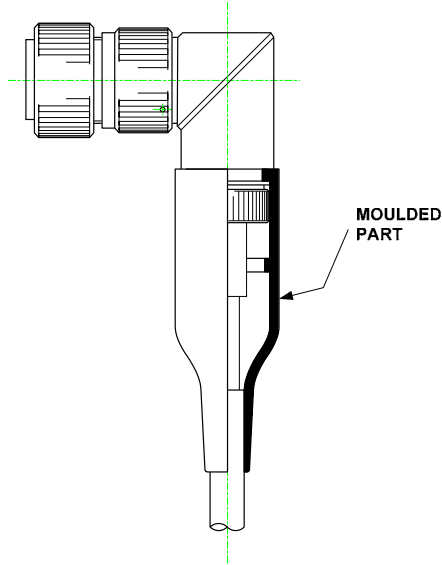

- Use in conjunction with the ferrule HET-A-05X **ONLY**, which are purchased separately. Refer to HET-A-05X S.C.D. for relevant details.

## **INSTALLATION**

- See Installation Procedure RPIP-696-07 (45° or 90° bodies) for assembly.
- See Installation Procedure RPIP-696-00 for cable termination.

## **PACKAGING**

- All components are supplied in a plastic bag.

## **NOTES!**

1. Assembly to be permanently marked with Code Identity Number and Part Number.  
(e.g. 06090 HXS121-AC-90-21-A1-1)

© 2008 Tyco Electronics. All rights reserved.

 <b>Raychem</b> Wire and Harnessing Products 300 Constitution Drive Menlo Park, CA 94025, USA				TITLE: <b>HEXASHIELD ADAPTOR FOR                  CODE 54 CONNECTOR – O/NO 20                  PLAIN CLAMPING NUT</b>			
UNLESS OTHERWISE SPECIFIED DIMENSIONS ARE IN MILLIMETERS. INCH DIMENSIONS ARE SHOWN IN BRACKETS		Tyco Electronics reserves the right to amend this drawing at any time. Users should evaluate the suitability of the product for their application.		DOCUMENT NO. <b>HXS121-AY-90-21-A1-1</b>			
DRAWN: IRT	DATE: JAN 08	CAGE CODE: 06090	DCR # ECO-08-019355	FILE: 87003/121	SCALE: NONE	SHEET: 3 OF 3	

If this document is printed it becomes uncontrolled. Check for the latest revision