

ESP32-A1S Module

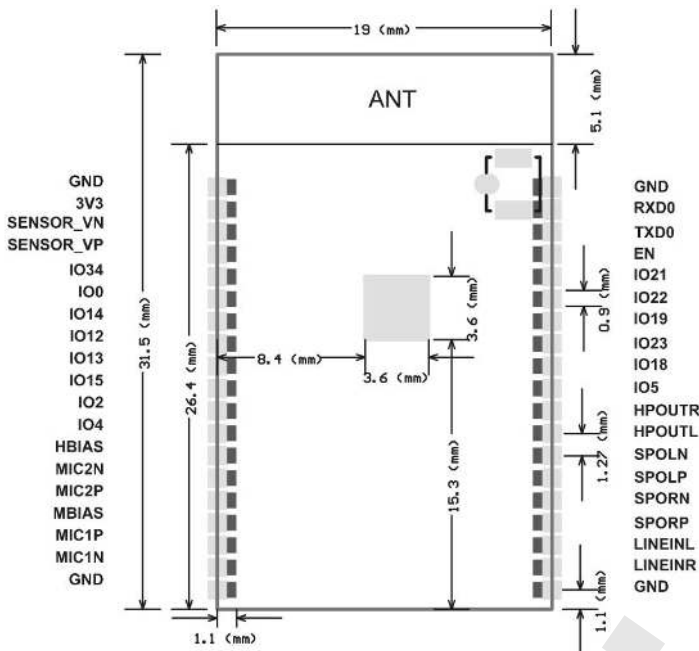

Features

- The smallest 802.11b/g/n Wi-Fi BT SoC Module
- Low power 32-bit CPU, can also serve the application processor
- Built-in AC101 Codec audio decoding chip, can support playing music and recording
- Built-in 520 KB SRAM, external 4MPSRAM
- Supports UART/SPI/I2C/PWM/ADC/DAC
- Support for firmware upgrade (FOTA)
- Antenna supports on-board antenna or IPEX block output
- Supports a variety of mainstream compression and lossless audio formats, including M4A, AAC, FLAC, OGG, OPUS, MP3, WAV, etc.
- Supports audio input methods such as MIC and Line-in.

Overview

ESP32-A1S is an ultra-small, powerful module. Built-in advanced low-power dual-core 32-bit CPU and Codec AC101 audio decoding chip, can be widely used in various IoT applications, suitable for home smart devices, smart Audio, story machine solutions, etc., are the ideal solution for IoT applications.

ESP32-A1S internal circuit is highly integrated, supports a variety of peripherals, can support secondary development, and quickly realize product differentiation.

ESP32-A1S adopts SMD package to realize rapid production of products and provide customers with high-reliability connection mode. It is especially suitable for modern, large-scale, low-cost production methods, and is convenient for various IoT hardware terminal applications.

Product Specifications

Module Model	ESP32-A1S
Package	SMD-38
Size	32mm*19mm*3mm
SPI Flash	Default 32Mbit
RAM	520KB SRAM +4M PSRAM
Bluetooth	Bluetooth 4.2 BR/EDR and BLE standards, support A2DP, AVRC protocol, etc.
Wi-Fi	802.11 b/g/n/, Support DLNA protocol
Audio Output	Support 1 channel headphone output and 1 channel left and right speaker output
Audio Input	Support LINEIN and 2-way MIC input
Custom IO port	14
UART Baudrate	Default 115200 bps
Audio Format	MP3、WAV、M4A、AAC、FLAC、OGG、OPUS
Antenna	Onboard PCB antenna or IPEX antenna
Transmit Power	802.11b: 17±2 dBm (@11Mbps) 802.11g: 14±2 dBm (@54Mbps) 802.11n: 13±2 dBm (@MCS7)
Receiving Sensitivity	CCK, 1 Mbps : -90dBm CCK, 11 Mbps: -85dBm 6 Mbps (1/2 BPSK): -88dBm 54 Mbps (3/4 64-QAM): -70dBm MCS7 (65 Mbps, 72.2 Mbps): -67dBm
Power Dissipation	350mA
Security	WPA/WPA2/WPA2-Enterprise/WPS
Power Supply Range	3.3V± 0.3V
Operating Temperature	-20 °C ~ 85 °C
Storage Environment	-40 °C ~ 90 °C , < 90%RH
Weight	2.5±0.05g

Module pin definition

GPIO	Features	Types	Remarks
TXD0	GPIO1/CLKOUT2	I/O	Download serial port
RXD0	GPIO3/CLKOUT3	I/O	
EN		I	Reset function
IO21	U0CTS/VSPIQ	I/O	
IO22	U0RTS/VSPiWP	I/O	
IO19	VSIQ/U0CTS	I/O	
IO23	VSPiDHS1STROBE	I/O	
IO18	VSPiCLK/HS1DATA7	I/O	
IO5	VSPiCS0	I/O	
HPOUTR		O	Headphone output
HPOUTL		O	
SPOLN		O	Speaker left channel output
SPOLP		O	
SPORN		O	Speaker right channel output
SPORP		O	
LINEINL		I	Headphone input
LINEINR		I	
SENSOR_VN	GPIO34/ADC1_3RTCIO3	I	
SENSOR_VP	GPIO36/ADC1_0/RTCIO0	I	
IO34	ADC1_6/RTCIO4	I	
IO0		I/O	Must be hanging when using internal codec
IO14	ADC2_6/RTCIO16/SDCLK/HS PICKJ/HS2CLK	I/O	
IO12	ADC2_5/RTCIO15/HSPiQ/SD DATA2/HS2DATA2	I/O	
IO13	ADC2_4/RTCIO14/HSPiD/SD DATA3/H2DATA3	I/O	
IO15	ADC2_3/RTCIO15/HSPiCS0/SDCMD/HS2CMD	I/O	
IO2	ADC2_2/RTCIO12/SDDATA0/	I/O	

	HS2DATA0		
IO4	ADC2_3/RTCIO10/HSPIHD/S DDATA1/HS2DATA1	I/O	
HBIAS		O	MIC2 control pin
MIC2N		I	MIC2 input
MIC2P		I	
MBIAS		O	MIC1 control pin
MIC1P		I	MIC1 input
MIC1N		I	

Strapping pin

System startup mode			
PIN	Default	Normal operation	Download
GPIO0	Pull up	NC	0
GPIO2	Pull down	Irrelevant item	0
Built-in LDO (VDD_SDIO) voltage			
PIN	Default	3.3V	1.8V
MTDI/GPIO12	Pull down	0	1

Note: the built-in flash working voltage is 3.3 V, and the model chip with built-in flash needs to pull down or suspend the MTDI when it is powered on.

Module schematic

ESP32 AC101 I2SPin connection

AC101	ESP32
I2S_SDOUT	IO35
I2S_SDIN	IO25
I2S_LRCK	IO26
I2S_BCLK	IO27
I2S_MCLK	IO0

ESP32 AC101 I2C Pin connection

AC101	ESP32
SCL	IO32
SDA	IO33

Minimum system diagram

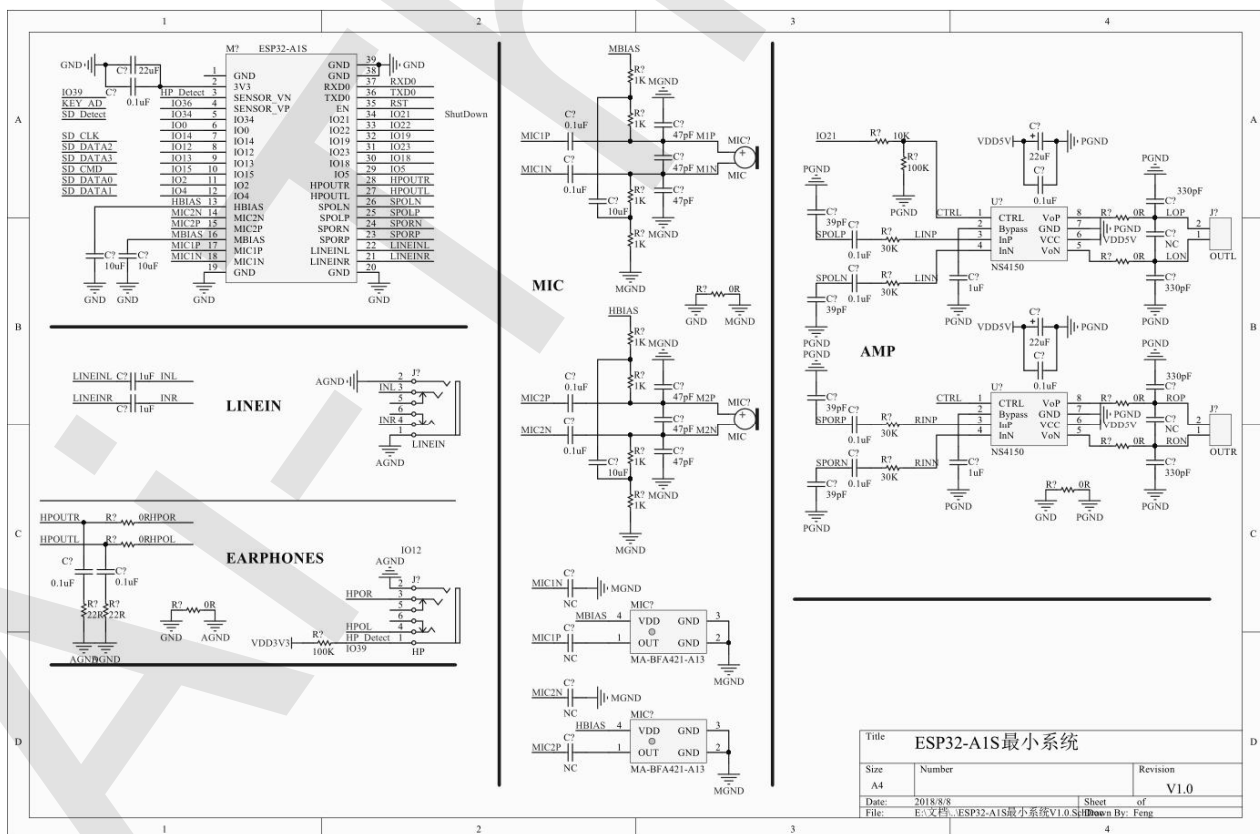

Download

<http://wiki.ai-thinker.com/esp32-a1s>

Contact US

Shenzhen Ai-Thinker Technology Co., Ltd

**Address: 7/F, Fengze Building B, Huafeng Industrial Park 2th, Hangkong street, Xixiang Raod, Baoan, Shenzhen
China**

Website: www.ai-thinker.com

Tel: 0755-29162996

E-mail: support@aithinker.com