

Amplifier Built-in
Leak Detection Sensor

EX-F70_{SERIES} EX-F60_{SERIES}



EX-F70 SERIES EX-F60 SERIES



High-speed detection even a little liquid leak

EX-F70 SERIES

Reliable detection

The unique effect of capillarity enables reliable detection of small leaks and viscous liquids.

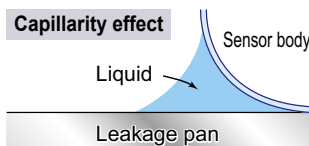

New type of detection method

When a leak occurs, the beam from the beam-emitting part scatters through the leaked liquid and is not transmitted to the beam-receiving part.

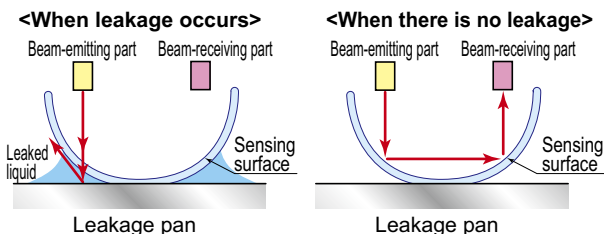

The beam from the beam-emitting part scatters through the leaked liquid and is not transmitted to the beam-receiving part.

The beam from the beam-emitting part reflects off of the surface of the sensor and is transmitted to the beam-receiving part.

Compact, space-saving

This slim (10 mm 0.394 in) side-mounting sensor is especially good for use in confined spaces.

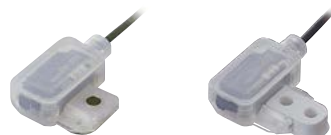
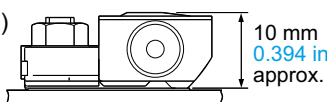

SUS mounting bracket type
EX-F71□

PVC mounting bracket type
EX-F72□

No need for sensitivity adjustment

No need for sensitivity adjustment with adjuster, so initial mounting is easy.

Easy operation check

This sensor is equipped with a NORMAL indicator (green) which lights up when mounting correctly, and a FAULT indicator (red) which lights up when sensing the leaked liquid or when mounted incorrectly (forgetting to mount exclusive mounting bracket). So, the operation can be checked easily.

Safe design

If the sensor is not mounted correctly, if the cable is broken or disconnected, or if the sensor is not operating correctly, the output is the same as when the beam is not received (LEAK). Design deals with human errors such as, forgetting to mount, etc.

Easy installation & reset

Facilitates easy installation: the SUS mounting bracket type can be installed using only a single screw and the PVC mounting bracket type can be installed using only two screws or an adhesive. No component replacement required for resetting after leak detection. The simple shape makes it easy to wipe off the leaked liquid.

PVC mounting bracket available

EX-F72□

A mounting bracket made of PVC (polyvinyl chloride) is available. This mounting bracket can be used normally in environments that would corrode normal metal brackets.

EX-F60 SERIES**PFA enclosure gives excellent chemical resistance**

The sensor enclosure and the cable sheath are made from PFA which is highly resistant to chemicals. Accurate sensing is achieved even if there are leaks of chemicals such as sulfuric acid, hydrochloric acid or ammonia.

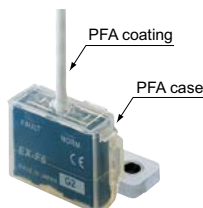
**Easy installation & reset**

The simplified shape makes it easy to clean up after liquid leaks, simply by wiping off the liquid, and no parts need to be replaced.

Compact, space-saving

Even with its built-in amplifier, the size is compact at W26 × H19 × D9 mm **W1.024 × H0.748 × D0.354 in**, so that it can be used even in narrow spaces.

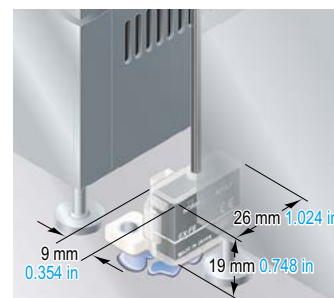
**EX-FC1****Wire-saving unit made especially for connecting leak detection sensors!****Saves wiring! Connects up to 8 leak detection sensors**

EX-FC1 is a simple wire-saving unit for exclusive use with **EX-F71/F72, EX-F61/F62** leak detection sensors. (It can be used with general sensors as well.)

EX-FC1 integrates the outputs from up to 8 leak detection sensors into a single OR output, so significant wiring and space savings are achieved.

* Even with only one leak detection sensor connected, an OFF signal is output if the sensor detects liquid leakage, or if the unit has been installed incorrectly.

Slim & compact

Space savings are significant, as the ultra-thin & compact **EX-FC1** has main unit body dimensions of only W20 × H80 × D52 mm **W0.787 × H3.150 × D2.047 in**.

Connects easily with one-touch connector

Connections are made by simply inserting the leak detection sensor cable leads into the snap male connector **SL-CP1**, then push until the connector snap-locks! This saves the time and the trouble of stripping the insulation from each lead before attaching to terminals.

**ORDER GUIDE****Leak detection sensors**

Type	Appearance	Sensing object	Cable length	Model No.	Output
General purpose	SUS mounting bracket type	Water, Fluorinert™ (Note 1, 2)	2 m 6.562 ft	EX-F71	NPN open-collector transistor
				EX-F71-PN	PNP open-collector transistor
	PVC mounting bracket type			EX-F72	NPN open-collector transistor
				EX-F72-PN	PNP open-collector transistor
Chemical-resistant	PFA mounting bracket type	Agent, such as Sulfuric acid, Hydrochloric acid, Phosphoric acid or Ammonia etc. (Note 1, 3, 4)	3 m 9.843 ft	EX-F61	NPN open-collector transistor
				EX-F61-PN	PNP open-collector transistor
	PVC mounting bracket type			EX-F62	NPN open-collector transistor
				EX-F62-PN	PNP open-collector transistor

- Notes: 1) Highly viscous liquid may not be detected stably.
 2) Fluorinert is the world wide trademark of 3M.
 3) The agents mentioned above are examples. For details, please contact our office.
 4) PVC mounting brackets may not be suitable for use depending on the concentration of the detection target. For details, please contact our office.

5 m 16.404 ft cable length type

5 m **16.404 ft** cable length type (standard: 2 m **6.562 ft** or 3 m **9.843 ft**) is also available.

When ordering this type, suffix "-C5" to the model No. (e.g.) 5 m **16.404 ft** cable length type of **EX-F71-PN** is "**EX-F71-PN-C5**".

Simple wire-saving unit for leak detection sensor

Appearance	Model No.	Output
	EX-FC1	Relay contact 1 a

OPTIONS

Designation	Model No.	Description
Unit mounting bracket	MS-DIN-3	Mounting bracket for EX-FC1
Connector end cap	SC-PK	Connector end cap for EX-FC1 8 pcs. per set

Unit mounting bracket

- **MS-DIN-3**

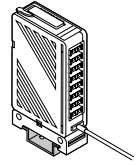

Accessories

- **MS-EX-F7-1**
(SUS mounting bracket)

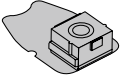

- **MS-EX-F7-2**
(PVC mounting bracket for adhesive fixing)

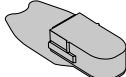

- **MS-EX-F7-3**
(PVC mounting bracket for two-point fixing)

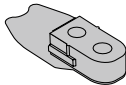

- **MS-EX-F6-1**
(PFA mounting bracket)

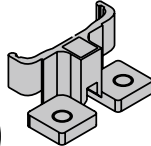

- **MS-EX-F6-2**
(PVC mounting bracket)

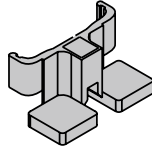

- **SL-CP1**
(Snap male connector)
10 pcs. per set

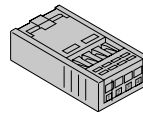

- **MS-SL-2**
(Unit mounting base)

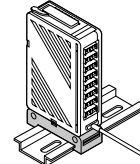

Connector end cap

- **SC-PK**

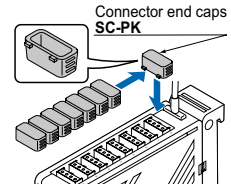

SPECIFICATIONS

Sensors

Item	Model No.	Type	General purpose		Chemical-resistant	
			SUS mounting bracket type	PVC mounting bracket type	PFA mounting bracket type	PVC mounting bracket type
			NPN output	EX-F71	EX-F72	EX-F61
		PNP output	EX-F71-PN	EX-F72-PN	EX-F61-PN	EX-F62-PN
CE marking directive compliance			EMC Directive, RoHS Directive			
Sensing object			Water, Fluorinert™ (Note 2, 3)		Agent, such as Sulfuric acid, Hydrochloric acid, Phosphoric acid or Ammonia etc. (Note 2, 4, 6)	
Supply voltage			12 to 24 V DC ±10 %		Ripple P-P 10 % or less	
Current consumption			10 mA or less (PNP output type: 15 mA or less)		15 mA or less	
Output			<NPN output type> NPN open-collector transistor <ul style="list-style-type: none"> • Maximum sink current: 50 mA • Applied voltage: 30 V DC or less (between output and 0 V) • Residual voltage: 1.0 V or less (at 50 mA sink current) 0.4 V or less (at 16 mA sink current) 		<PNP output type> PNP open-collector transistor <ul style="list-style-type: none"> • Maximum source current: 50 mA • Applied voltage: 30 V DC or less (between output and +V) • Residual voltage: 1.0 V or less (at 50 mA source current) 0.4 V or less (at 16 mA source current) 	
Utilization category			DC-12 or DC-13			
Output operation			In normal state: ON, When leak detected or the sensor is mounted improperly: OFF			
Short-circuit protection			Incorporated			
Response time			50 ms or less			
FAULT indicator			Red LED (lights up when the leak liquid is detected, or the sensor is mounted improperly)			
NORMAL indicator			Green LED (lights up when the sensor is mounted properly)			
Pollution degree			3 (Industrial environment)			
Protection			IP67 (IEC)			
Ambient temperature			-10 to +60 °C +14 to +140 °F (No dew condensation or icing allowed), Storage: -20 to +70 °C -4 to +158 °F (Note 5)			
Ambient humidity			35 to 85 % RH, Storage: 35 to 85 % RH			
Ambient illuminance			Incandescent light: 1,000 lx or less at the light-receiving face			
Emitting element			Infrared LED (non-modulated)			
Material			Enclosure: Polypropylene		Enclosure: PFA	
Cable			0.1 mm ² 3-core PVC cabtyre cable, 2 m 6.562 ft long		0.1 mm ² 3-core PFA cabtyre cable, 3 m 9.843 ft long	
Cable extension			Extension up to total 50 m 164.042 ft is possible with 0.3 mm ² , or more, cable.			
Weight			Net weight: 25 g approx.		Net weight: 60 g approx.	
Accessories			MS-EX-F7-1 (SUS mounting bracket) (Note 7): 1 pc.	MS-EX-F7-2, MS-EX-F7-3 (PVC mounting bracket) (Note 7): 1 pc. each for two-point-fixing and adhesive-fixing	MS-EX-F6-1 (PFA mounting bracket): 1 pc.	MS-EX-F6-2 (PVC mounting bracket): 1 pc.

Notes: 1) Where measurement conditions have not been specified precisely, the conditions used were an ambient temperature of +20 °C **+68 °F**.

2) Highly viscous liquid may not be detected stably.

3) Fluorinert is the world wide trademark of 3M.

4) The agents mentioned above are examples. For details, please contact our office.

5) Liquid being detected should also be kept within the rated ambient temperature range.

6) PVC mounting bracket may not be used depending on type or viscosity etc. of the agent. For details, please contact our office.

7) The mounting bracket for **EX-F71(-PN)** is not interchangeable with that of **EX-F72(-PN)** due to the different sensitivity settings of each sensor.

SPECIFICATIONS

Simple wire-saving unit

Designation	Simple wire-saving unit for leak detection sensor	
Item	Model No.	EX-FC1
CE marking directive compliance	EMC Directive, RoHS Directive	
Applicable connector	SL-CP1	
Supply voltage	12 to 24 V DC $\pm 10\%$ Ripple P-P 10 % or less	
Current consumption	50 mA or less (for the unit itself), 135 mA or less (including the sensor input current when all outputs of sensors are ON)	
Output	Relay contact 1a <ul style="list-style-type: none"> Switching capacity: 30 V 1 A DC (resistive load) Min. applied load: 10 mV 10 μA DC Electrical lifetime: 100,000 switching operations or more (rated load, switching frequency 20 operations/min.) Mechanical lifetime: 50 million switching operations or more (switching frequency 180 operations/min.) 	
	Utilization category	DC-12 or DC-13
	Output operation	The output relay is ON when the input signal from the sensor is ON (Note 2)
Response time	5 ms or less (excluding the response time of the sensor)	
Input No.	8 Nos.	
Indicators	Normal	Green LED $\times 8$ (light up when the sensor is connected to each channel and the connection setting switch is set to ON)
	Error	Red LED $\times 8$ (light up when the leak liquid is detected by a sensor connected to each channel or a sensor is mounted improperly)
	Output	Orange LED [lights up when the output relay is ON (normal)]
Pollution degree	3 (Industrial environment)	
Ambient temperature	-10 to +60 °C +14 to +140 °F (No dew condensation or icing allowed), Storage: -20 to +70 °C -4 to +158 °F	
Ambient humidity	35 to 85 % RH, Storage: 35 to 85 % RH	
Material	Enclosure: ABS, Unit mounting base: POM, Terminal part: PBT	
Cable	0.2 mm ² 4-core cabtyre cable, 2 m 6.562 ft long	
Cable extension	Extension up to total less than 10 m 32.808 ft is possible, with 0.3 mm ² , or more, cable.	
Weight	Net weight: 85 g approx.	
Accessories	SL-CP1 (Snap male connector): 8 pcs., MS-SL-2 (Unit mounting base): 1 pc.	

Notes: 1) Where measurement conditions have not been specified precisely, the conditions used were an ambient temperature of +20 °C **+68 °F**.

2) Even with only one leak detection sensor connected, an OFF signal is output if the sensor detects liquid leakage, or if the unit has been installed incorrectly.

I/O CIRCUIT AND WIRING DIAGRAMS

EX-F7□ EX-F6□

NPN output type

I/O circuit diagram

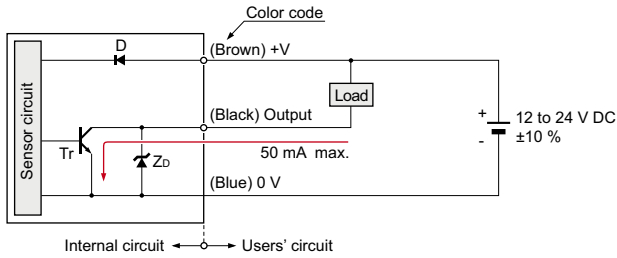

Symbols ... D : Reverse supply polarity protection diode
 ZD: Surge absorption zener diode
 Tr : NPN output transistor

Wiring diagram

EX-F7□

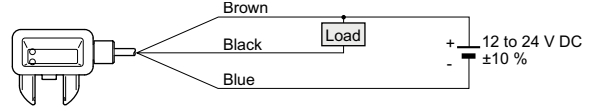

EX-F6□

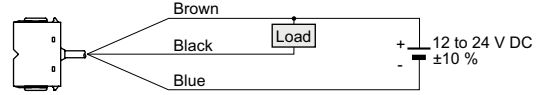

EX-F7□-PN EX-F6□-PN

PNP output type

I/O circuit diagram

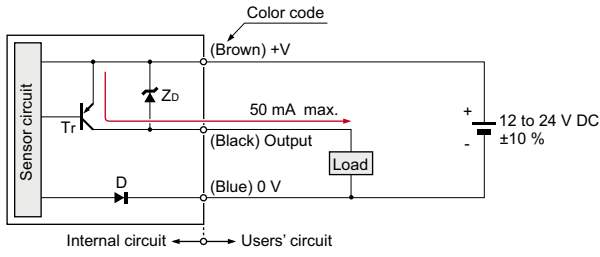

Symbols ... D : Reverse supply polarity protection diode
 ZD: Surge absorption zener diode
 Tr : PNP output transistor

Wiring diagram

EX-F7□-PN

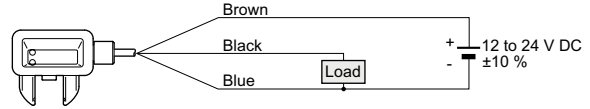

EX-F6□-PN

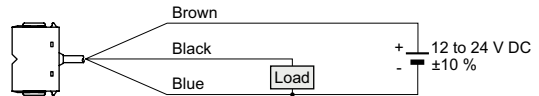

EX-FC1

Simple wire-saving unit for leak detection sensor

I/O circuit diagram (for one channel)

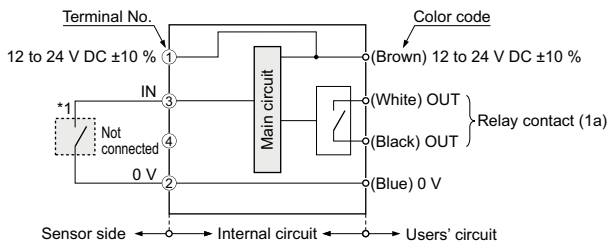

Note: The output does not incorporate a short-circuit protection circuit.
 Do not connect it directly to a power supply or a capacitive load.

* 1

Non-voltage contact or NPN open-collector transistor
 (Amplifier built-in leak detection sensor)

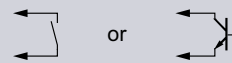

PRECAUTIONS FOR PROPER USE



- Never use this product as a sensing device for personnel protection.
- In case of using sensing devices for personnel protection, use products which meet laws and standards, such as OSHA, ANSI or IEC etc., for personnel protection applicable in each region or country.

EX-F71(-PN) EX-F72(-PN)

Mounting

EX-F71(-PN)

- Insert the M4 stud-bolt (length 10 mm **0.394 in** or more) welded on the user's facilities into the mounting hole of the SUS mounting bracket and screw with an M4 nut (please arrange separately). The tightening torque should be 0.98 N·m or less.

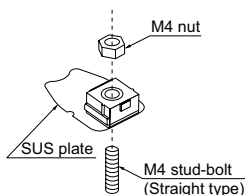

EX-F72(-PN)

<In case of using the two-point-fixing PVC mounting bracket>

- Insert M4 stud-bolts (length 10 mm **0.394 in** or more) welded on the user's facilities into the mounting holes of the two-point-fixing mounting bracket and screw with M4 nuts (please arrange separately). The tightening torque should be 0.49 N·m or less.

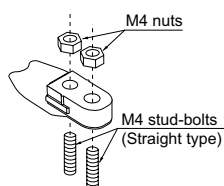

<In case of using the PVC mounting bracket for adhesive fixing>

- Use adhesive to stick fast the mounting bracket on the mounting surface. Please note that if the adhesive sticks out from the bottom surface of the mounting bracket or is 0.5 mm **0.020 in**, or more thick, the sensor body cannot be fitted to the mounting bracket.

How to fit the sensor body to the exclusive mounting bracket

- Match the notch in the sensor body with the projection of the exclusive mounting bracket and slide till a click is felt.
- When mounting, make sure to use the brackets included with the unit in order to eliminate human error (such as forgetting to install). If the included brackets are not used, stable sensing is rendered impossible. Also, because sensitivity settings differ between the **EX-F71(-PN)** and the **EX-F72(-PN)**, their brackets cannot be interchanged.

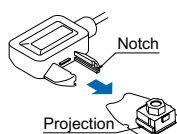

EX-F61(-PN) EX-F62(-PN)

Mounting

EX-F61(-PN)

- Insert the M4 stud-bolt (length 10 mm **0.394 in** or more) welded on the user's facilities into the mounting hole of the PFA mounting bracket and screw with an M4 nut (please arrange separately). The tightening torque should be 0.98 N·m or less.

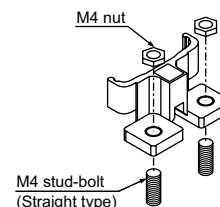

EX-F62(-PN)

- Please note that if the excess adhesive from the bottom surface of the exclusive mounting bracket is remained, the sensing capability may be affected. Use adhesive for vinyl chloride (PVC).

How to fit the sensor body to the exclusive mounting bracket

- Align the projections in the sensor body with the notches of the exclusive mounting bracket and slide till a click is felt.

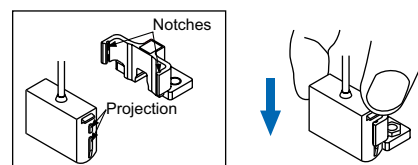

How to remove the sensor body from the exclusive mounting bracket

- Pinch the projections of the sensor body and pull the body upwards. Never pull the cable, since it may cause a cable break.



PRECAUTIONS FOR PROPER USE

EX-FC1

Mounting

- When mounting the unit, be sure to use the unit mounting base (**MS-SL-2**) (accessory).
- When installing the unit mounting base to the unit, insert the base aligned with the grooves of the unit and move until the unit stopper is locked.

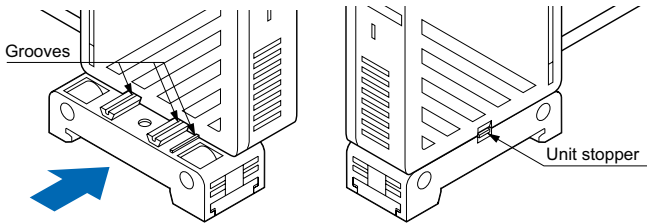

- Two installation positions are available for the unit mounting base so that the unit direction can be changed. Install the base at one of them.

Mounting position 1

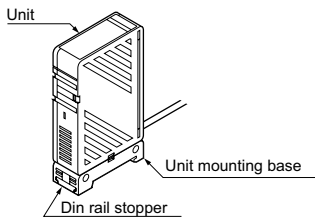

Mounting position 2

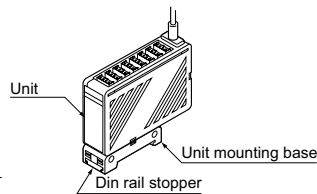

<In case of using a DIN rail or the mounting bracket (MS-DIN-3) (optional)>

- ① Fit the rear part of the unit mounting base on a 35 mm 1.378 in width DIN rail or the mounting bracket (**MS-DIN-3**) (optional).
- ② Press down the front part of the unit mounting base on the 35 mm 1.378 in width DIN rail or the mounting bracket (**MS-DIN-3**) (optional) and fit the front part of the base.

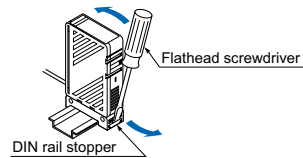
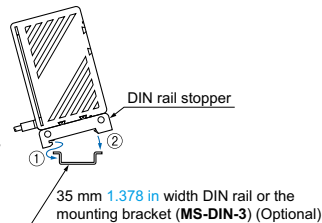

- * For removal, insert a flathead screwdriver into the DIN rail stopper and pull towards yourself.

<In case of using screws>

- Mount using M4 pan head screws with a tightening torque of 0.8 N·m or less. However, in case of side mounting, make sure to mount the unit such that the unit stopper faces front.

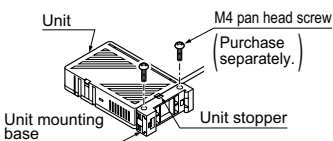

Part description

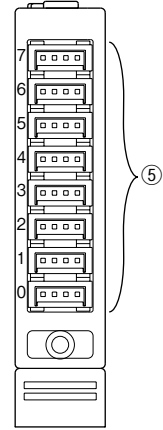
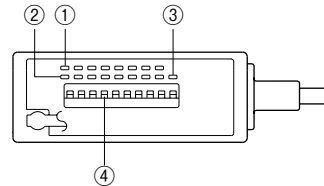

	Designation	Function
①	Normal indicator (Green LED × 8)	Lights up when sensors are connected to each channel and the connection setting switch is set to ON.
②	Error indicator (Red LED × 8)	Lights up when leak is detected by any sensor connected or any sensor is mounted improperly. [For details, refer to “ Connection setting switch ” (p.9).
③	Output indicator (Orange LED)	Lights up when the output relay is ON (Normal).
④	Connection setting switch	Set the switch to ON when the leak detection sensor is connected, set to OFF when the leak detection sensor is not connected.
⑤	Connector	Connect the leak detection sensors.

Connection

- Make sure to connect or disconnect the snap male connector (**SL-CP1**) in the power supply off condition.
- Take care that wrong wiring will damage the product.
- The terminal No. 4 of the snap male connector (**SL-CP1**) is not used. Take care not to connect to the terminal No. 4 by mistake. Further, if there are unused wires, please insulate them.

	Content
①	+V
②	0 V
③	IN
④	No connected

- For details of the hook-up method of the snap male connector (**SL-CP1**), refer to the Instruction Manual enclosed with **SL-CP1**.

Connection method

- By holding the **SL-CP1** with the cable connected, insert it into the connector of the **EX-FC1** reliably till it stops.

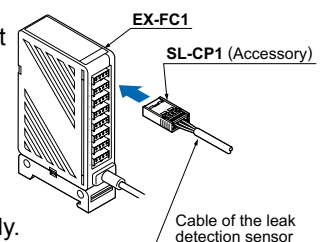

Disconnection method

- By holding **SL-CP1**, pull it from the **EX-FC1** horizontally.

Note: Do not pull out by holding the cable, as this can result in cable disconnection.

PRECAUTIONS FOR PROPER USE

EX-FC1

Connection setting switch

- The connection setting should be carried out in the power supply off condition after removing any electrostatic charge which may be present on your body.

Operation matrix for each indicator

Operation	Connection state of the leak detection sensor	State of the connection setting switch	Leak detected condition	Normal indicator (Green)	Error indicator (Red)	Output indicator (Orange)
Normal	Connected	ON	Not leaked	Lights up	Turns off	Lights up
			Leaked	Turns off	Lights up	Turns off
Error	Unconnected	OFF	—	Turns off	Turns off	Lights up
			Connected	OFF	Not leaked	Lights up
Error	Unconnected	ON	—	Turns off	Lights up	Turns off
			Connected	ON	Leaked	Lights up

- For the channel that the unit sensor is connected to and the connection setting switch is set to "ON" side, the error indicator (red) lights up for a moment when the power is turned on. This is not a malfunction for the unit because it is caused by characteristic of the sensor.
- Make sure to set the connection setting switch with the connector No. to which the leak detection sensor is connected, to "ON" side.
- In case both the normal indicator (green) and the error indicator (red) light up, the connection setting switch with the connector No. to which the leak detection sensor is connected, is not set to "ON" side. Set the connection setting switch with the connector No. to which the leak detection sensor is connected, to "ON" side.
- In case the error indicator (red) lights up, the leak detection sensor detects leak or the connection setting switch is set to "ON" side without connecting the leak detection sensor. If the connection setting switch is set to "ON" side without connecting the leak detection sensor, set the connection setting switch to "OFF" side.
- If the leak detection sensor detects leak or the connection setting switch is set to "OFF" side in the state that the leak detection sensor is improperly mounted to the mounting bracket, the sensor judges as the output is ON. Be careful when setting.

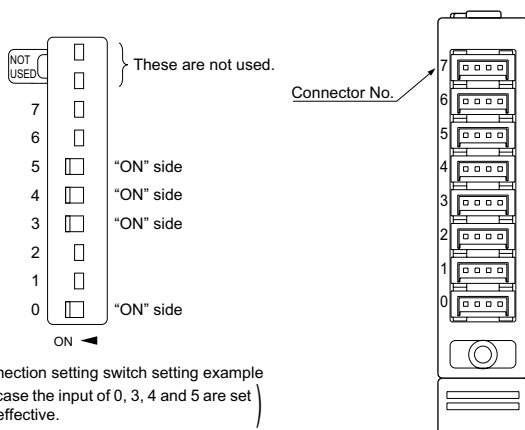

All models

Wiring

- Make sure that the power supply is off while wiring.
- Verify that the supply voltage variation is within the rating. Take care that if a voltage exceeding the rated range or an AC power supply is directly applied, the sensor may get damaged or burnt.
- If power is supplied from a commercial switching regulator, ensure that the frame ground (F.G.) terminal of the power supply is connected to an actual ground.
- In case noise generating equipment (switching regulator, inverter motor, etc.) is used in the vicinity of this product, connect the frame ground (F.G.) terminal of the equipment to an actual ground.
- Do not run the wires together with high-voltage lines or power lines or put them in the same raceway. This can cause malfunction due to induction.
- Make sure to use an isolation transformer for the DC power supply. If an auto-transformer (single winding transformer) is used, this product or the power supply may get damaged.
- In case a surge is generated in the used power supply, connect a surge absorber to the supply and absorb the surge.
- Cable extension is possible up to total 50 m **164.05 ft** with 0.3 mm², or more, cable (less than 10 m **32.81 ft** for **EX-FC1**). However, in order to reduce noise, make the wiring as short as possible.
- Make sure that stress by forcible bend or pulling is not applied directly to the sensor cable joint.
- EX-FC1** output does not incorporate a short-circuit protection circuit. Do not connect it directly to a power supply or a capacitive load.

Others

- Avoid using the product in an explosive atmosphere because this product does not have an explosive-proof protective construction.
- When liquid remains on the sensing surface after leak detection, wipe all liquid from the sensing surface. To avoid scratching the sensing surface and the enclosed mounting bracket, use a soft cloth.

- In case air bubbles are drawn into the sensing part, take care that it may take some time for sensing to stabilize, or sensing may even become unstable. Check the usage conditions thoroughly before use.
- Do not use during the initial transient time (leak detection sensor: 50 ms approx., **EX-FC1**: 0.5 sec. approx.) after the power supply is switched on.
- Since this sensor employs non-modulated infrared LED, take sufficient care against extraneous light. Do not expose the sensing part directly to the extraneous light.
- Avoid dust, dirt, and steam. Further, do not use this product in an environment containing organic solvents.
- Take care that **EX-7□(-PN)** and **EX-FC1** does not come in contact with oil, grease or organic solvents, such as, thinner, etc.
- In case this sensor is used where electrostatic charge is present, use a metal leak pan, which should be connected to an actual ground.
- These sensors are only for indoor use.

DIMENSIONS (Unit: mm in)

The CAD data can be downloaded from our website.

EX-F71(-PN) EX-F72(-PN)

Sensor

Assembly dimensions with mounting bracket for EX-F71(-PN)

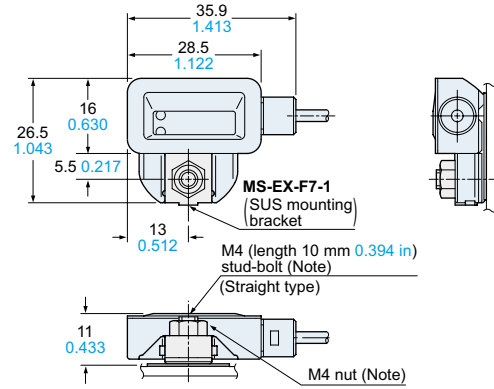
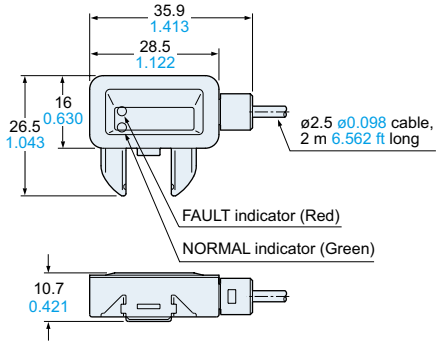

Note: A M4 stud-bolt has been welded to this unit.
M4 nut is not supplied with the sensor.
Purchase it separately.

Assembly dimensions with mounting bracket for EX-F72(-PN)

MS-EX-F7-3 / For two-point-fixing

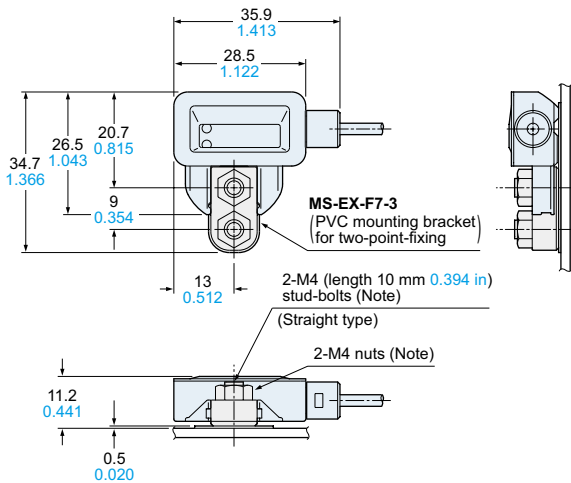

Note: M4 stud-bolts have been welded to this unit.
M4 nuts are not supplied with the sensor.
Purchase it separately.

MS-EX-F7-2 / For adhesive fixing

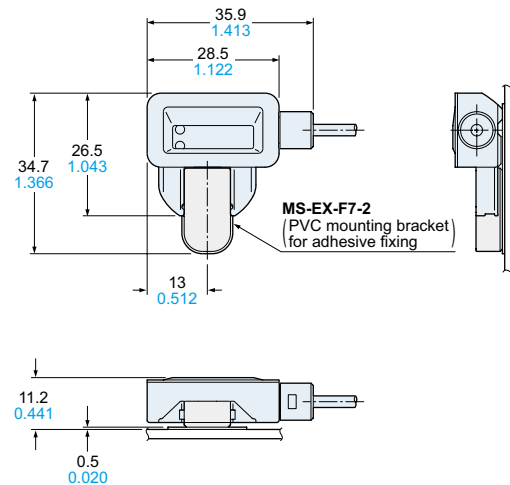

DIMENSIONS (Unit: mm in)

The CAD data can be downloaded from our website.

EX-F61(-PN) EX-F62(-PN)

Sensor

Assembly dimensions with mounting bracket for EX-F61(-PN)

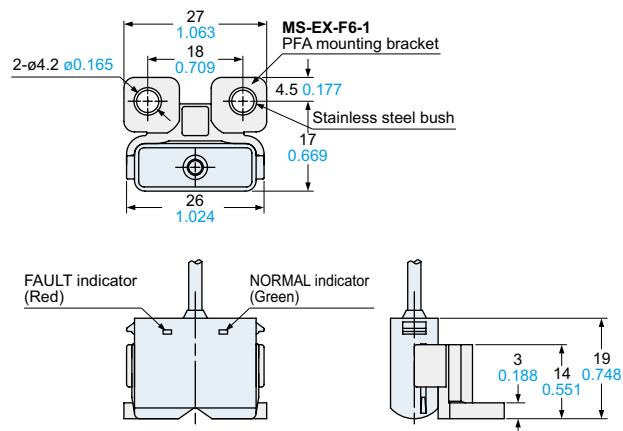
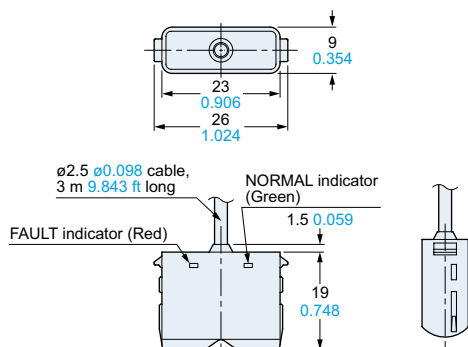

Assembly dimensions with mounting bracket for EX-F62(-PN)

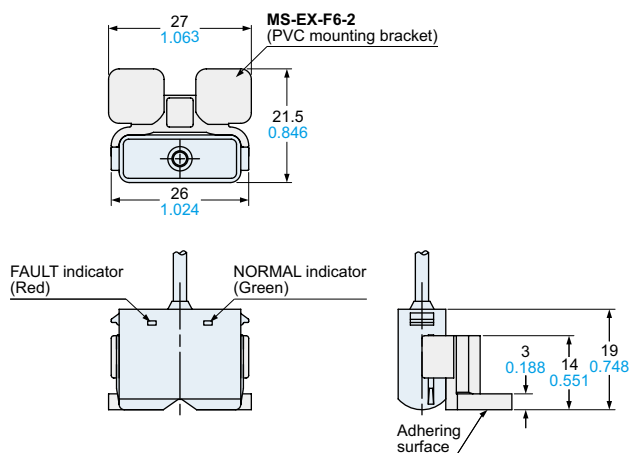

EX-FC1 Simple wire-saving unit for leak detection sensor

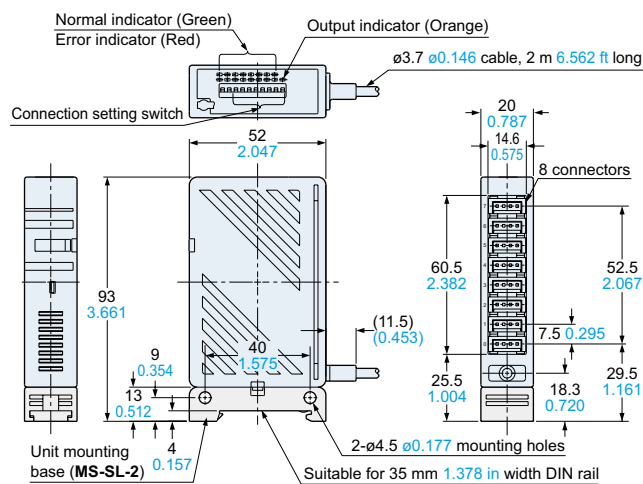

MS-DIN-3 Unit mounting bracket (Optional)

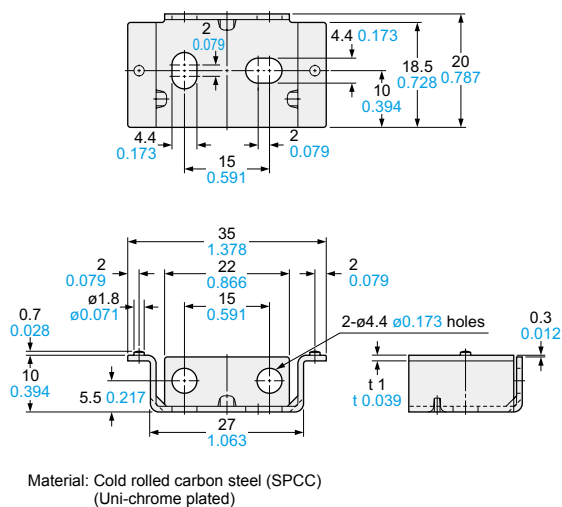

Disclaimer

The applications described in the catalog are all intended for examples only. The purchase of our products described in the catalog shall not be regarded as granting of a license to use our products in the described applications. We do NOT warrant that we have obtained some intellectual properties, such as patent rights, with respect to such applications, or that the described applications may not infringe any intellectual property rights, such as patent rights, of a third party.

Panasonic
INDUSTRY

Panasonic Industry Co., Ltd.

Industrial Device Business Division

7-1-1, Morofuku, Daito-shi, Osaka 574-0044, Japan

industrial.panasonic.com/ac/e/