

S1C17M40 (rev 1.0)

16-bit Single Chip Microcontroller

- Low power operation with embedded 48K bytes Flash.
- Support 1.8V to 5.5V wide range operating voltage.
- Equipped with an LCD driver capable of driving 36 SEG × 8COM / 40 SEG × 4 COM LCD panel.

■ DESCRIPTIONS

The S1C17M40 is a 16-bit MCU that features low power consumption. It includes various serial interfaces, an LCD driver, a temperature sensor, an A/D converter, and various timers as well as a high-performance 16-bit CPU.

It is suitable for battery-driven applications that require an LCD display and a temperature measurement function.

The S1C17M40 has not only a Flash memory but also an EEPROM that can be reprogrammed from an application software.

■ FEATURES

Package type	64-pin package		48-pin package
CPU			
CPU core	Seiko Epson original 16-bit RISC CPU core S1C17		
Other	On-chip debugger		
Embedded Flash Memory			
Capacity	48K bytes (for both instructions and data)		
Erase/program count	1, 000 times(min.) *Programming by the debugging tool ICDmini		
Other	On-board programming function using ICDmini Flash programming voltage can be generated internally.		
EEPROM			
Capacity	256 bytes		
Erase/program count	100,000 times(min.)		
Embedded RAM			
Capacity	2K bytes		
Embedded display RAM			
Capacity	80 bytes		
Clock generator(CLG)			
System clock source	4 sources (IOSC/OSC1/OSC3/EXOSC)		
System clock frequency (operating frequency)	16.8 MHz (max.)		
IOSC oscillator circuit (boot clock source)	700kHz(typ.) embedded oscillator		
	23 μs(max.) starting time (time from cancelation of SLEEP state to vector table read by the CPU)		
OSC1 oscillator circuit	32.768 kHz (typ.) crystal oscillator		-
	32 kHz (typ.) embedded oscillator		
	Oscillation stop detection circuit included		-
OSC3 oscillator circuit	16 MHz(typ.) embedded oscillator (accuracy +-1%@Ta=0 to 85°C)		
EXOSC clock input	16.8 MHz (max.) square or sine wave input		
Other	Configurable system clock division ratio		
	Configurable system clock used at wake up from SLEEP state		
	Operating clock frequency for the CPU and all peripheral circuits is selectable		
I/O port (PPORT)			
Number of general-purpose I/O ports	In/Out	54 Bits (max.)	48 Bits (max.)
	Out	1 bit (max.)	1 bit (max.)
Number of input interrupt ports	52 bits (max.)		38 bits (max.)
Number of ports that support universal port multiplexer (UPMUX)	32 bits (max.)		27 bits (max.)
	A peripheral circuit I/O function selected via software can be assigned to each port.		

S1C17M40 (rev 1.0)

Package type	64-pin package	48-pin package
Timers		
Watchdog timer(WDT2)	Generates NMI or watchdog timer reset	
Real-time clock(RTCA)	128–1 Hz counter, second/minute/hour/day/day of the week/month/year counters.	
	Theoretical regulation function for 1-second correction	
	Alarm and stopwatch functions	
16-bit timer(T16)	4 channels	
	Generates the SPIA master clocks and the ADC12A trigger signals	
16-bit PWM timer (T16B)	3 channels	
	Event counter/capture function	
	PWM waveform generation function	
	Number of PWM output or capture input ports: 2 ports/channel	
Supply voltage detector (SVD4)		
Detection voltage	VDD or external voltage (one external voltage input port is provided and an external voltage level can be detected even if it exceeds VDD.)	
Detection level	VDD: 32 levels (1.7 to 5.0 V)/external voltage: 32 levels (1.7 to 5.0 V)	
Other	Intermittent operation mode	
	Generates an interrupt or reset according to the detection level evaluation.	
Serial interfaces		
UART (UART3)	3 channels	
	Baud-rate generator included	
	IrDA1.0 supported, Open drain output, Polar character is selectable	
	Support modulated output function for IrDA communication carrier	
Synchronous serial interface (SPIA)	2 channels	
	2 to 16-bit variable data length	
	The 16-bit timer(T16) can be used for the baud-rate generator in master mode.	
I ² C (I2C)	1 channel	
	Baud-rate generator included	
Sound generator (SNDA)		
Buzzer output function	512 Hz to 16 kHz output frequencies	
	One-shot output function	
Melody generation function	Pitch: 128 Hz to 16 kHz ≈ C3 to C6	
	Duration: 7 notes/rests (Half note/rest to thirty-second note/rest)	
	Tempo: 16 tempos (30 to 480)	
	Tie/slur may be specified.	
IR remote controller (REMC3)		
Number of transmitter channels	1 channel	
Others	EL lamp drive waveform can be generated (by the hardware) for an application example.	
LCD driver (LCD8A)		
LCD output(max.)	36SEG x 8COM	24SEG x 8COM
	40SEG x 4COM	28SEG x 4COM
LCD Power	1/3 bias power supply included, external voltage can be applied. (Internal resistors are provided to divide the external source voltage.)	
LCD contrast	29 levels	
12-bit A/D converter (ADC12A)		
Conversion method	Successive approximation type	
Resolution	12 bits	
Number of conversion channels	1 channel	
Number of analog signal input	4 ports/channels+temp sensor	3 ports/channels+temp sensor
Temperature sensor/reference voltage generator (TSRVR)		
Temperature sensor circuit	Sensor output can be measured using ADC12A.	
Reference voltage generator	Reference voltage for ADC12A is selectable from 2.0 V, 2.5 V, VDD, and external input.	
Multiplier/divider(COPRO2)		
Arithmetic functions	16-bit × 16-bit multiplier	
	16-bit × 16-bit + 32-bit multiply and accumulation unit	
	32-bit ÷ 32-bit divider	

S1C17M40 (rev 1.0)

Package type	64-pin package	48-pin package
Reset		
#RESET pin	Reset when the reset pin is set to low	
Power-on reset	Reset at power on	
Brown-out reset	Reset in supply voltage declining	
Key entry reset	Reset when the P00 to P01/P02/P03 keys are pressed simultaneously (can be enabled/disabled using a register)	
Watchdog timer reset	Reset when the watchdog timer overflows (can be enabled/disabled using a register)	
Supply voltage detector reset	Reset when the supply voltage detector detects the set voltage level (can be enabled/disabled using a register)	
Interrupt		
Non-maskable interrupt	4 systems(Reset, address misaligned interrupt, debug, NMI)	
Programmable interrupt	External interrupt: 1system (8 levels)	
	Internal interrupt: 21 systems (8 levels)	
Power supply voltage		
VDD operating voltage	1.8V to 5.5V	
VC3 operating voltage	1.8V to 5.5V (Required when P30 or P31 by general purpose ports.)	
VDD operating voltage for Flash programming	2.2V to 5.5V (Programming voltage VPP: 7.5 V external voltage or internal boosted volt)	
VDD operating voltage for EEPROM programming	2.2V to 5.5V (Programming voltage VPP: only internal boosted voltage)	
Operating temperature		
Operating temperature range	-40°C to 85°C	
Current consumption (Typ. Value)		
SLEEP mode	0.25 μ A (typ.) IOSC = Off, OSC1=Off, OSC3 = Off	
HALT mode	1.4 μ A (typ.) OSC1=32kHz (internal oscillator)	
RUN mode	5.5 μ A (typ.) OSC1 = 32 kHz (internal oscillator), CPU = OSC1	
	1,850 μ A (typ.) OSC3 = 16 MHz (internal oscillator), CPU = OSC3, FLASHCWAIT[1:0]=0x2	
Shipping form		
PKG type	QFP13-64pin (Lead pitch: 0.5mm)	TQFP12-48pin (Lead pitch: 0.5mm)

S1C17M40 (rev 1.0)

■ BLOCK DIAGRAM

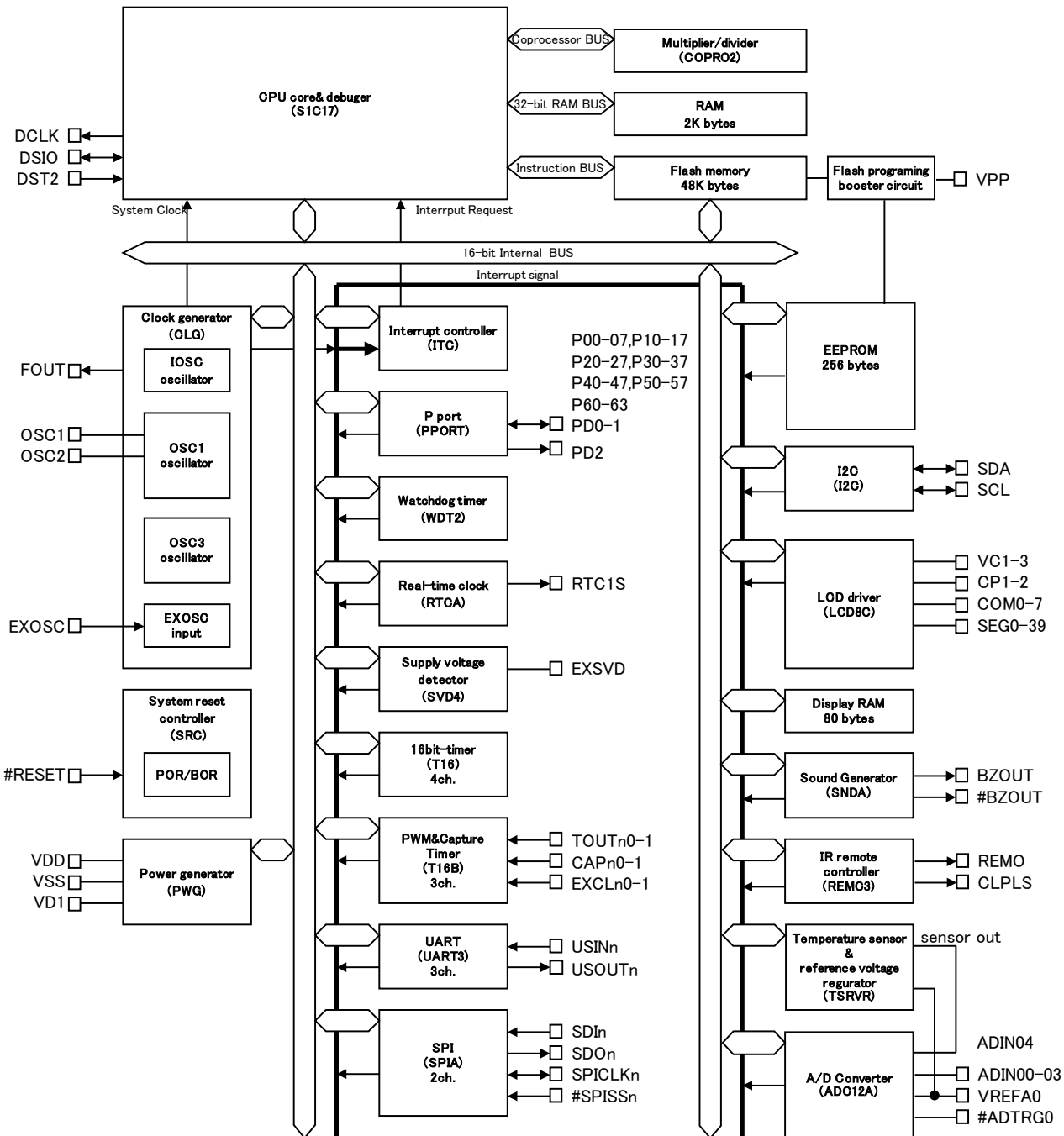

S1C17M40 (rev 1.0)

■ PIN CONFIGURATION DIAGRAMS

QFP13-64

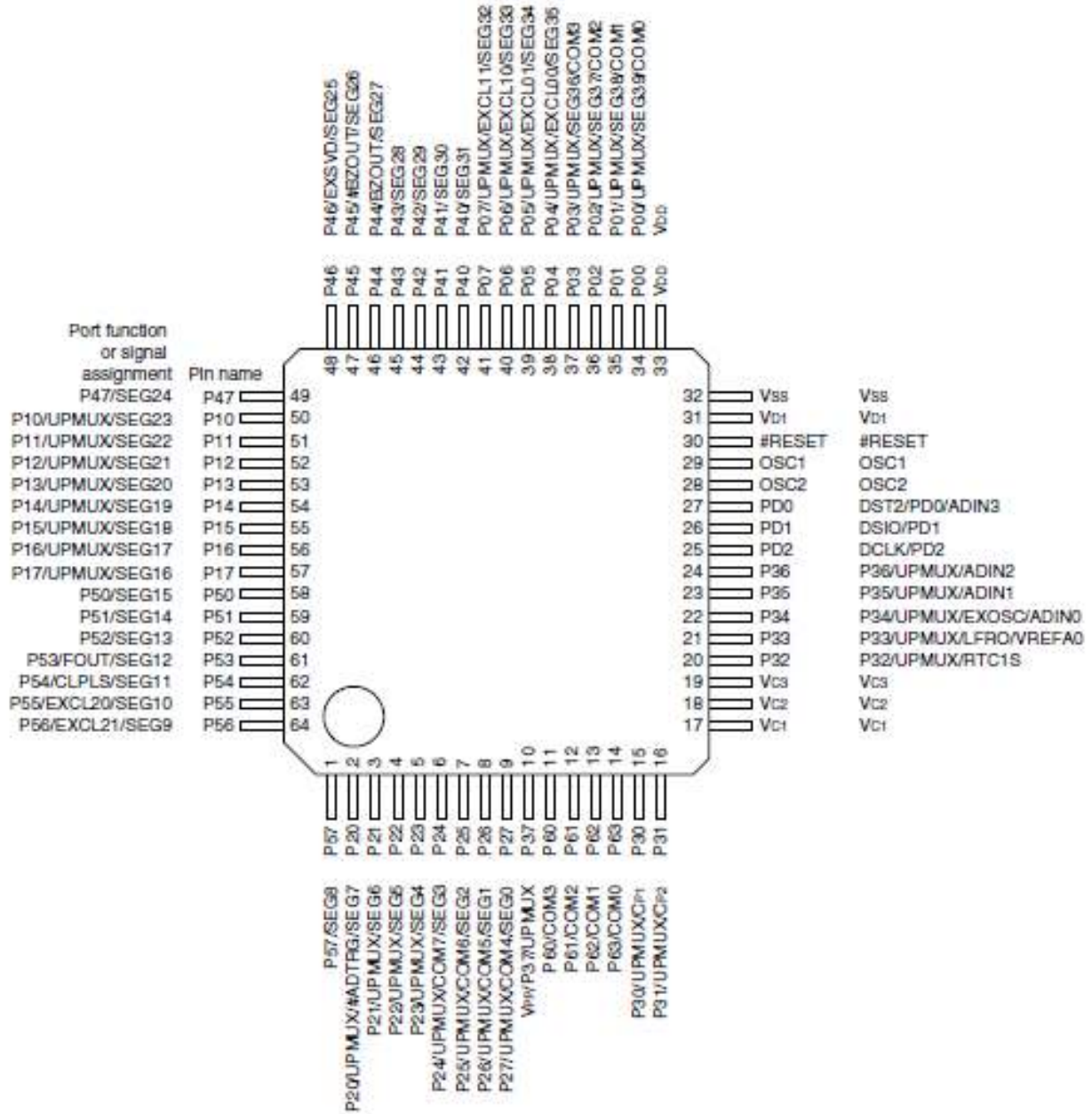

S1C17M40 (rev 1.0)

TQFP12-48

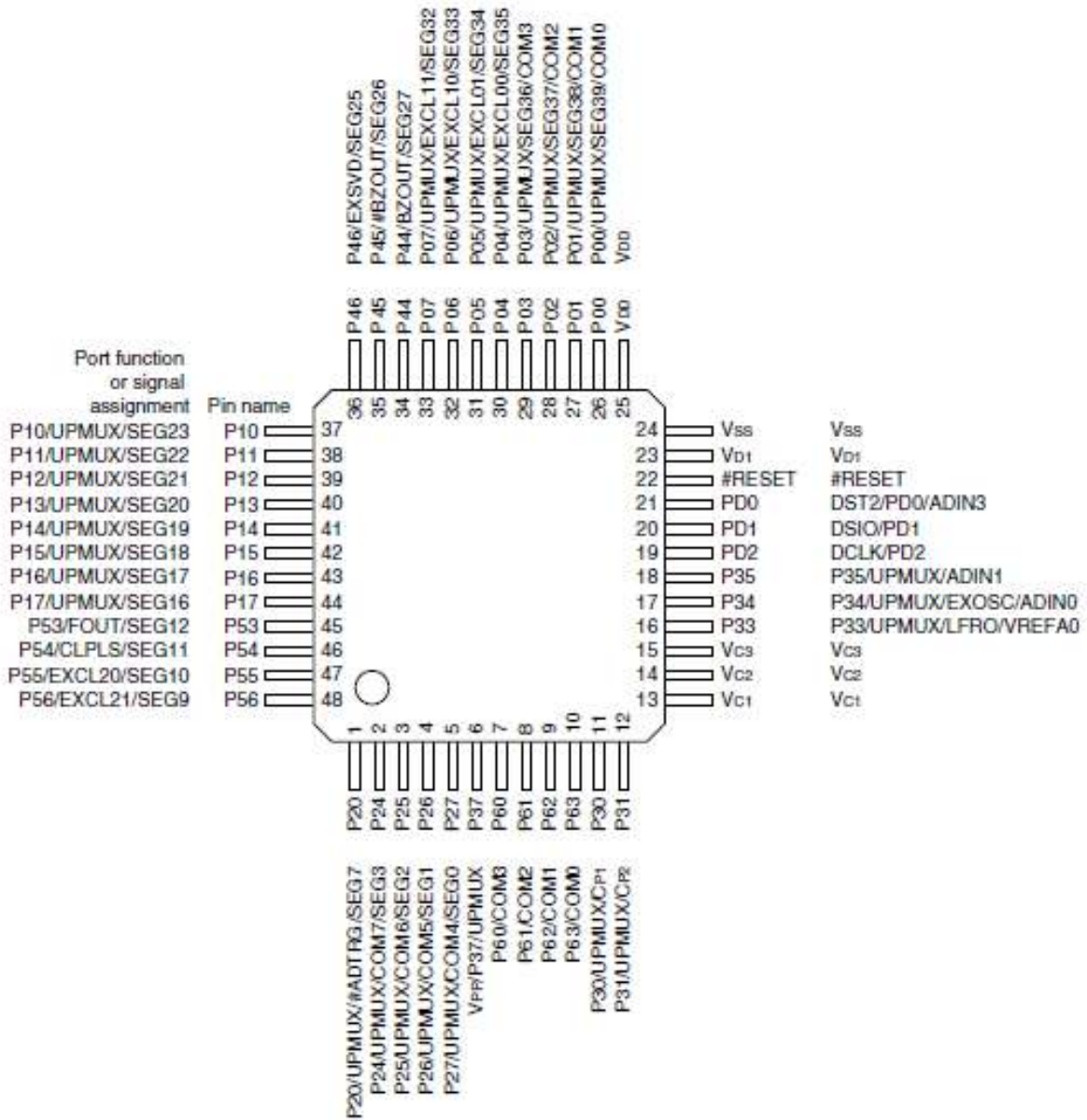

S1C17M40 (rev 1.0)

■ PIN DESCRIPTIONS

Symbol meanings

Assigned signal: The signal listed at the top of each pin is assigned in the initial state. The pin function must be switched via software to assign another signal (see the “I/O Ports” chapter).

I/O: I = Input
O = Output
I/O = Input/output
P = Power supply
A = Analog signal
Hi-Z = High impedance state

Initial state: I (Pull-up) = Input with pulled up
I (Pull-down) = Input with pulled down
Hi-Z = High impedance state
O (H) = High level output
O (L) = Low level output

Tolerant fail-safe structure:

✓ = Over voltage tolerant fail-safe type I/O cell included (see the “I/O Ports” chapter)

The over voltage tolerant fail-safe type I/O cell allows interfacing without passing unnecessary current even if a voltage exceeding VDD is applied to the port.

Also unnecessary current is not consumed when the port is externally biased without supplying VDD.

Pin name	Assigned signal	I/O	Initial state	Tolerant fail-safe structure	Function	64 pin PKG	48 pin PKG
VDD	VDD	P	-	-	Power supply (+)	✓	✓
VSS	VSS	P	-	-	GND	✓	✓
VD1	VD1	A	-	-	VD1 regulator output	✓	✓
VC1-3	VC1-3	P	-	-	LCD panel driver power supply	✓	✓
OSC1	OSC1	A	-	-	OSC1 oscillator circuit input	✓	
OSC2	OSC2	A	-	-	OSC1 oscillator circuit output	✓	
#RESET	#RESET	I	I(Pull-up)	-	Reset input	✓	✓
P00	P00	I/O	Hi-Z	✓	I/O port	✓	✓
	UPMUX	I/O			User-selected I/O (universal port multiplexer)		
	COM0	A			LCD common output		
	SEG39	A			LCD segment output		
P01	P01	I/O	Hi-Z	✓	I/O port	✓	✓
	UPMUX	I/O			User-selected I/O (universal port multiplexer)		
	COM1	A			LCD common output		
	SEG38	A			LCD segment output		
P02	P02	I/O	Hi-Z	✓	I/O port	✓	✓
	UPMUX	I/O			User-selected I/O (universal port multiplexer)		
	COM2	A			LCD common output		
	SEG36	A			LCD segment output		
P03	P03	I/O	Hi-Z	✓	I/O port	✓	✓
	UPMUX	I/O			User-selected I/O (universal port multiplexer)		
	COM3	A			LCD common output		
	SEG36	A			LCD segment output		
P04	P04	I/O	Hi-Z	✓	I/O port	✓	✓
	EXCL00	I/O			16-bit PWM timer Ch.0 event counter input 0		
	UPMUX	A			User-selected I/O (universal port multiplexer)		
	SEG35	A			LCD segment output		

S1C17M40 (rev 1.0)

Pin name	Assigned signal	I/O	Initial state	Tolerant fail-safe structure	Function	64 pin PKG	48 pin PKG
P05	P00	I/O	Hi-Z	✓	I/O port	✓	✓
	UPMUX	I/O			16-bit PWM timer Ch.0 event counter input 1		
	SEG39	A			User-selected I/O (universal port multiplexer)		
P06	P01	I/O	Hi-Z	✓	LCD segment output	✓	✓
	UPMUX	I/O			I/O port		
	SEG38	A			16-bit PWM timer Ch.1 event counter input 0		
P07	P02	I/O	Hi-Z	✓	User-selected I/O (universal port multiplexer)	✓	✓
	UPMUX	I/O			LCD segment output		
	COM2	A			I/O port		
	SEG36	A			16-bit PWM timer Ch.1 event counter input 1		
P10	P10	I/O	Hi-Z	✓	User-selected I/O (universal port multiplexer)	✓	✓
	UPMUX	I/O			LCD segment output		
	SEG23	A			I/O port		
P11	P11	I/O	Hi-Z	✓	User-selected I/O (universal port multiplexer)	✓	✓
	UPMUX	I/O			LCD segment output		
	SEG22	A			I/O port		
P12	P12	I/O	Hi-Z	✓	User-selected I/O (universal port multiplexer)	✓	✓
	UPMUX	I/O			LCD segment output		
	SEG21	A			I/O port		
P13	P13	I/O	Hi-Z	✓	User-selected I/O (universal port multiplexer)	✓	✓
	UPMUX	I/O			LCD segment output		
	SEG20	A			I/O port		
P14	P14	I/O	Hi-Z	✓	User-selected I/O (universal port multiplexer)	✓	✓
	UPMUX	I/O			LCD segment output		
	SEG19	A			I/O port		
P15	P15	I/O	Hi-Z	✓	User-selected I/O (universal port multiplexer)	✓	✓
	UPMUX	I/O			LCD segment output		
	SEG18	A			I/O port		
P16	P16	I/O	Hi-Z	✓	User-selected I/O (universal port multiplexer)	✓	✓
	UPMUX	I/O			LCD segment output		
	SEG17	A			I/O port		
P17	P17	I/O	Hi-Z	✓	User-selected I/O (universal port multiplexer)	✓	✓
	UPMUX	I/O			LCD segment output		
	SEG16	A			I/O port		
P20	P20	I/O	Hi-Z	✓	User-selected I/O (universal port multiplexer)	✓	✓
	#ADTRG0	I			LCD segment output		
	UPMUX	I/O			I/O port		
	SEG7	A			12-bit A/D converter Ch.0 trigger input		
P21	P21	I/O	Hi-Z	✓	User-selected I/O (universal port multiplexer)	✓	
	UPMUX	I/O			LCD segment output		
	SEG6	A			I/O port		

S1C17M40 (rev 1.0)

Pin name	Assigned signal	I/O	Initial state	Tolerant fail-safe structure	Function	64 pin PKG	48 pin PKG
P22	P22	I/O	Hi-Z	✓	I/O port	✓	
	UPMUX	I/O			User-selected I/O (universal port multiplexer)		
	SEG5	A			LCD segment output		
P23	P23	I/O	Hi-Z	✓	I/O port	✓	
	UPMUX	I/O			User-selected I/O (universal port multiplexer)		
	SEG4	A			LCD segment output		
P24	P24	I/O	Hi-Z	✓	I/O port	✓	✓
	UPMUX	I/O			User-selected I/O (universal port multiplexer)		
	COM7	A			LCD common output		
	SEG3	A			LCD segment output		
P25	P25	I/O	Hi-Z	✓	I/O port	✓	✓
	UPMUX	I/O			User-selected I/O (universal port multiplexer)		
	COM2	A			LCD common output		
	SEG43	A			LCD segment output		
P26	P26	I/O	Hi-Z	✓	I/O port	✓	✓
	UPMUX	I/O			User-selected I/O (universal port multiplexer)		
	COM1	A			LCD common output		
	SEG42	A			LCD segment output		
P27	P27	I/O	Hi-Z	✓	I/O port	✓	✓
	UPMUX	I/O			User-selected I/O (universal port multiplexer)		
	COM0	A			LCD common output		
	SEG41	A			LCD segment output		
P30	P30	I/O	Hi-Z	✓	I/O port	✓	✓
	UPMUX	I/O			User-selected I/O (universal port multiplexer)		
	CP1	A			LCD power supply booster capacitor connect pins		
P31	P31	I/O	Hi-Z	✓	I/O port	✓	✓
	UPMUX	I/O			User-selected I/O (universal port multiplexer)		
	CP2	A			LCD power supply booster capacitor connect pins		
P32	P32	I/O	Hi-Z	✓	I/O port	✓	
	RTC1S	O			Real-time clock 1-second cycle pulse output		
	UPMUX	I/O			User-selected I/O (universal port multiplexer)		
P33	P33	I/O	Hi-Z	✓	I/O port	✓	✓
	LFRO	O			LCD frame signal monitor output		
	UPMUX	I/O			User-selected I/O (universal port multiplexer)		
	VREFA0	A			"12-bit A/D converter Ch.0 reference voltage input, constant voltage output"		
P34	P34	I/O	Hi-Z	✓	I/O port	✓	✓
	EXOSC	I			Clock generator external clock input		
	UPMUX	I/O			User-selected I/O (universal port multiplexer)		
	ADIN0	A			12-bit A/D converter Ch.0 analog signal input 0		
P35	P35	I/O	Hi-Z	✓	I/O port	✓	✓
	UPMUX	I/O			User-selected I/O (universal port multiplexer)		
	ADIN1	A			12-bit A/D converter Ch.0 analog signal input 1		

S1C17M40 (rev 1.0)

Pin name	Assigned signal	I/O	Initial state	Tolerant fail-safe structure	Function	64 pin PKG	48 pin PKG
P36	P36	I/O	Hi-Z	✓	I/O port	✓	
	UPMUX	I/O			User-selected I/O (universal port multiplexer)		
	ADIN2	A			12-bit A/D converter Ch.0 analog signal input 2		
VPP/P37	VPP	P	Hi-Z	✓	Power supply for Flash programming	✓	✓
	P37	I/O			I/O port		
	UPMUX	I/O			User-selected I/O (universal port multiplexer)		
P40	P40	I/O	Hi-Z	✓	I/O port	✓	
	SEG31	A			LCD segment output		
P41	P41	I/O	Hi-Z	✓	I/O port	✓	
	SEG30	A			LCD segment output		
P42	P42	I/O	Hi-Z	✓	I/O port	✓	
	SEG29	A			LCD segment output		
P43	P43	I/O	Hi-Z	✓	I/O port	✓	
	SEG28	A			LCD segment output		
P44	P44	I/O	Hi-Z	✓	I/O port	✓	✓
	BZOUT	O			Sound generator output		
	SEG27	A			LCD segment output		
P45	P45	I/O	Hi-Z	✓	I/O port	✓	✓
	#BZOUT	O			Sound generator inverted output		
	SEG26	A			LCD segment output		
P46	P46	I/O	Hi-Z	✓	I/O port	✓	✓
	EXSVD	A			External power supply voltage detection input		
	SEG25	A			LCD segment output		
P47	P47	I/O	Hi-Z	✓	I/O port	✓	
	SEG24	A			LCD segment output		
P50	P50	I/O	Hi-Z	✓	I/O port	✓	
	SEG15	A			LCD segment output		
P51	P51	I/O	Hi-Z	✓	I/O port	✓	
	SEG14	A			LCD segment output		
P52	P52	I/O	Hi-Z	✓	I/O port	✓	
	SEG13	A			LCD segment output		
P53	P53	I/O	Hi-Z	✓	I/O port	✓	✓
	FOUT	O			Clock external output		
	SEG12	A			LCD segment output		
P54	P54	I/O	Hi-Z	✓	I/O port	✓	✓
	CLPLS	O			IR remote controller clear pulse output		
	SEG11	A			LCD segment output		
P55	P55	I/O	Hi-Z	✓	I/O port	✓	✓
	EXCL20	I			16-bit PWM timer Ch.2 event counter input 0		
	SEG10	A			LCD segment output		
P56	P56	I/O	Hi-Z	✓	I/O port	✓	✓
	EXCL21	I			16-bit PWM timer Ch.2 event counter input 1		
	SEG9	A			LCD segment output		

S1C17M40 (rev 1.0)

Pin name	Assigned signal	I/O	Initial state	Tolerant fail-safe structure	Function	64 pin PKG	48 pin PKG
P57	P55	I/O	Hi-Z	✓	I/O port	✓	
	SEG8	A			LCD segment output		
P60	P60	I/O	Hi-Z	✓	I/O port	✓	✓
	COM3	A			LCD common output		
P61	P61	I/O	Hi-Z	✓	I/O port	✓	✓
	COM2	A			LCD common output		
P62	P62	I/O	Hi-Z	✓	I/O port	✓	✓
	COM1	A			LCD common output		
P63	P63	I/O	Hi-Z	✓	I/O port	✓	✓
	COM0	A			LCD common output		
PD0	DST2	O	Hi-Z		On-chip debugger status output	✓	✓
	PD0	I/O			I/O port		
	ADIN3	A			12-bit A/D converter Ch.0 analog signal input 3		
PD1	DSIO	I/O	I(Pull-up)		On-chip debugger data input/output	✓	✓
	PD1	I/O			I/O port		
PD2	DCLK	O	O(H)		On-chip debugger clock output	✓	✓
	PD2	O			Output port		

Universal port multiplexer (UPMUX)

The universal port multiplexer (UPMUX) allows software to select the peripheral circuit input/output function to be assigned to each pin from those listed below.

Peripheral circuit	Signal to be assigned	I/O	Channel number n	Function
Synchronous serial interface (SPIA)	SDI_n	I	$n=0,1$	SPIA Ch. n data input
	SDO_n	O		SPIA Ch. n data output
	$SPICLK_n$	I/O		SPIA Ch. n clock input/output
	$\#SPISS_n$	I		SPIA Ch. n slave-select input
I ² C (I2C)	SCL_n	I/O	$n=0$	I2C Ch. n clock input/output
	SDA_n	I/O		I2C Ch. n data input/output
UART (UART3)	$USIN_n$	I	$n=0,1,2$	UART Ch. n data input
	$USOUT_n$	O		UART Ch. n data output
16-bit PWM timer (T16B)	$TOUT_{n0}/CAP_{n0}$	I/O	$n=0$	T16B Ch. n PWM output/capture input 0
	$TOUT_{n1}/CAP_{n1}$	I/O		T16B Ch. n PWM output/capture input 1
IR remote controller (REMC)	REMO	O	$n=0$	IR remote controller transmit data output

Note: Do not assign a function to two or more pins simultaneously.

S1C17M40 (rev 1.0)

NOTICE:

No part of this material may be reproduced or duplicated in any form or by any means without the written permission of Seiko Epson. Seiko Epson reserves the right to make changes to this material without notice. Seiko Epson does not assume any liability of any kind arising out of any inaccuracies contained in this material or due to its application or use in any product or circuit and, further, there is no representation that this material is applicable to products requiring high level reliability, such as, medical products. Moreover, no license to any intellectual property rights is granted by implication or otherwise, and there is no representation or warranty that anything made in accordance with this material will be free from any patent or copyright infringement of a third party. When exporting the products or technology described in this material, you should comply with the applicable export control laws and regulations and follow the procedures required by such laws and regulations. You are requested not to use, to resell, to export and/or to otherwise dispose of the products (and any technical information furnished, if any) for the development and/or manufacture of weapon of mass destruction or for other military purposes.

All brands or product names mentioned herein are trademarks and/or registered trademarks of their respective companies.

©Seiko Epson Corporation 2019, All rights reserved

Seiko Epson Corporation

Sales & Marketing Division

Device Sales & Marketing Department

421-8 Hino, Hino-shi, Tokyo 191-8501, JAPAN

Phone: +81-42-587-5814 FAX: +81-42-587-5116

EPSON semiconductor website

global.epson.com/products_and_drivers/semicon/

Document code: 413875400
Issue August 2019 in JAPAN