

used for: D-SUB HD FILTER

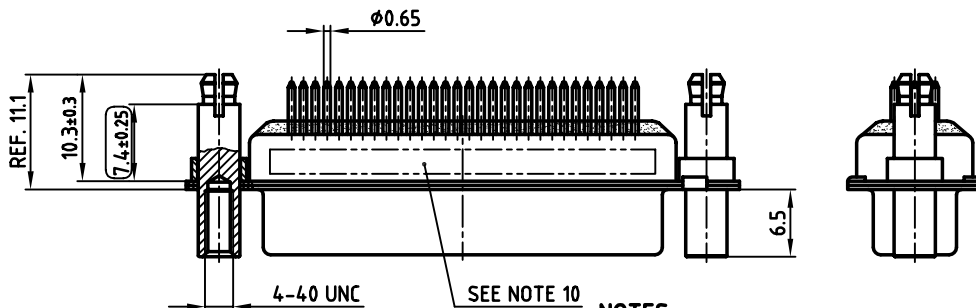
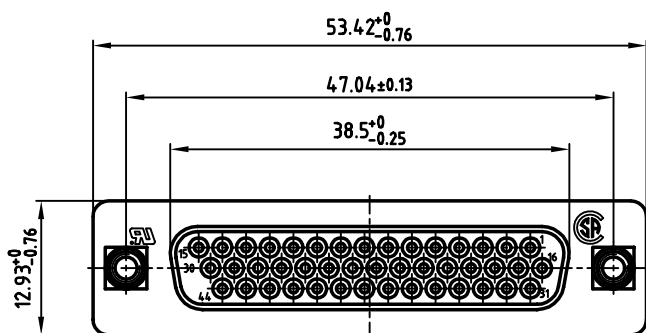
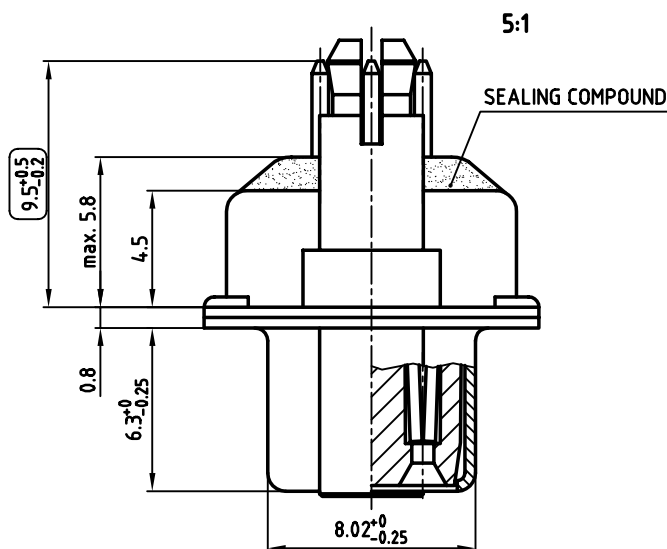

NOTES:

1. METALSHELLS: STEEL; min. 320µ" TIN
2. INSULATORS: PBT GF UL 94 V-0, BLACK
3. CONTACTS: COPPER ALLOY
PLATING: 8µ" HARD GOLD OVER min. 50µ" NICKEL
4. THREADED LOCK/SPACER CLIP: COPPER ALLOY; min. 200µ" TIN over 80µ" NICKEL
PCB-HOLE: $\phi 3.1 \pm 0.1$; PCB THICKNESS 1.6mm
5. COLLAR: COPPER ALLOY; min. 200µ" TIN over 80µ" NICKEL
6. P.C.B. HOLE DRILLINGS ON DRAWING NO.: 16V1IH6B
7. CAPACITANCE: SEE TABLE
8. DIELECTRIC WITHSTANDING VOLTAGE: 300V DC
9. MAXIMUM TORQUE VALUE FOR THREAD: 6" LBS
10. CONNECTOR IS PART MARKED: PART-NO. CONEC Y/WW
11. = CHECK DIMENSION

CAPACITANCE	PART NO.
180pF ±20%	242A27800X
370pF ±20%	242A20790X
830pF ±20%	242A20830X

APPROVAL * FREIGABE * DEBLOCAGE * AUTORIZACION * APPROVAL

CUSTOMER APPROVAL DATE:

NAME: TITLE:

COMPANY NAME:

APPROVAL * FREIGABE * DEBLOCAGE * AUTORIZACION * APPROVAL

THIS DRAWING MAY NOT BE COPIED OR REPRODUCED IN ANY WAY, AND MAY NOT BE PASSED ON TO A THIRD PARTY, WITHOUT WRITTEN PERMISSION. OWNERSHIP AND COPYRIGHT OF CONEC GmbH DO NOT ALTER CAD DRAWING BY HAND

rev.	description	date	name

tolerance		scale:	2:1 (5:1)
	dim. in mm	material:	SEE NOTES
2003	date	name	title:
drawn	16.09.	Lehmenkühler	D-SUB HD FILTER FEMALE
appd.	19.09.	Mickenbecker	44pos. SOLDER PIN STRAIGHT
norm		DIN 41652	with threaded lock and spacer clip
d-old			dwg no: AutoCAD 2000
			DIN-A
			3
part no: SEE TABLE			sh: 1/1

dwg no:	AutoCAD 2000	DIN-A
		3
		sh: 1/1
part no:	SEE TABLE	