

LOC	DIST	REVISIONS			
GP	00	REV	DATE	DWN	APVD
		A	RELEASED PER ECO-08-003778	20FEB2008	RG PD

1. PART NUMBER CHANGES AND OR DESIGN CHANGES AFFECTING ITEM INTERCHANGEABILITY REQUIRE PRIOR TYCO ELECTRONICS APPROVAL AND AUTHORIZATION BY REVISION TO THIS DRAWING.

2. MATERIAL:  
 HOUSING: GLASS FILLED POLYESTER, COLOR-BLACK  
 UL94 -V0 FLAMMABILITY RATED  
 LATCHES: THERMOPLASTIC, GLASS REINFORCED,  
 COLOR: BLACK, UL94 -V0  
 CONTACTS: COPPER ALLOY

3. FINISH:  
 SIGNAL CONTACTS:  
 1.27µm MIN NICKEL PLATE ALL OVER EXCEPT IN MATING AREA  
 MATING AREA : 0.76µm MIN GOLD OVER 3.81µm MIN NICKEL  
 COMPLIANT TAILS: 2.0µm MIN TIN OVER NICKEL PLATE  
 POWER CONTACTS:  
 1.27µm MIN NICKEL PLATE ALL OVER  
 MATING AREA: 0.76µm MIN GOLD OVER NICKEL PLATE  
 COMPLIANT TAILS: 1.78µm MIN TIN OVER NICKEL PLATE

4. ITEMS PROVIDED TO THIS SPECIFICATION TO BE PERMANENTLY IDENTIFIED WITH PART NUMBER AND DATE CODE.

5. MAXIMUM BURR OF 0.013 ON CARD TAB AREA.

6. SET TRACE BACK FROM PC BOARD EDGE. NO SOLDERMASK ALLOWED BETWEEN PC BOARD EDGE AND TRACE.

7. CONNECTOR ACCEPTS 1.57±0.13 THICK PC BOARD.

8. KEEP OUT AREA FOR COMPONENTS ONLY.

9. FEATURE REQUIRED FOR USE WITH EJECTOR.

10. CAUTION:  
 LATCHES ARE INTENDED FOR RETENTION OF PC BOARD TO CONNECTOR. DO NOT ATTEMPT TO FULLY EJECT PC BOARD FROM CONNECTOR WHILE DISENGAGING LATCHES, DAMAGE TO LATCHES AND OR CONNECTOR MAY OCCUR.

11. RECOMMENDED GOLD FINGER LENGTH FOR RELIABLE CONTACT.

12. DATUMS AND BASIC DIMENSIONS ESTABLISHED BY CUSTOMER.

13. APPLY SOLDERMASK TO COVER TRACES ROUTED WITHIN SIGNAL CONTACTS TAIL REGION.

14. RECOMMENDED PRINTED CIRCUIT BOARD HOLE:  
 FINISHED HOLE : Ø1.02±0.05  
 DRILLED HOLE : Ø1.15±0.013  
 COPPER PLATE : 0.025 - 0.050 (PER SURFACE)  
 TIN PLATE : 0.0005 MIN (PER SURFACE)

15. RECOMMENDED PRINTED CIRCUIT BOARD HOLE:  
 FINISHED HOLE : Ø0.56±0.05  
 DRILLED HOLE : Ø0.65±0.018  
 COPPER PLATE : 0.025 - 0.050 (PER SURFACE)  
 TIN PLATE : 0.0005 MIN (PER SURFACE)

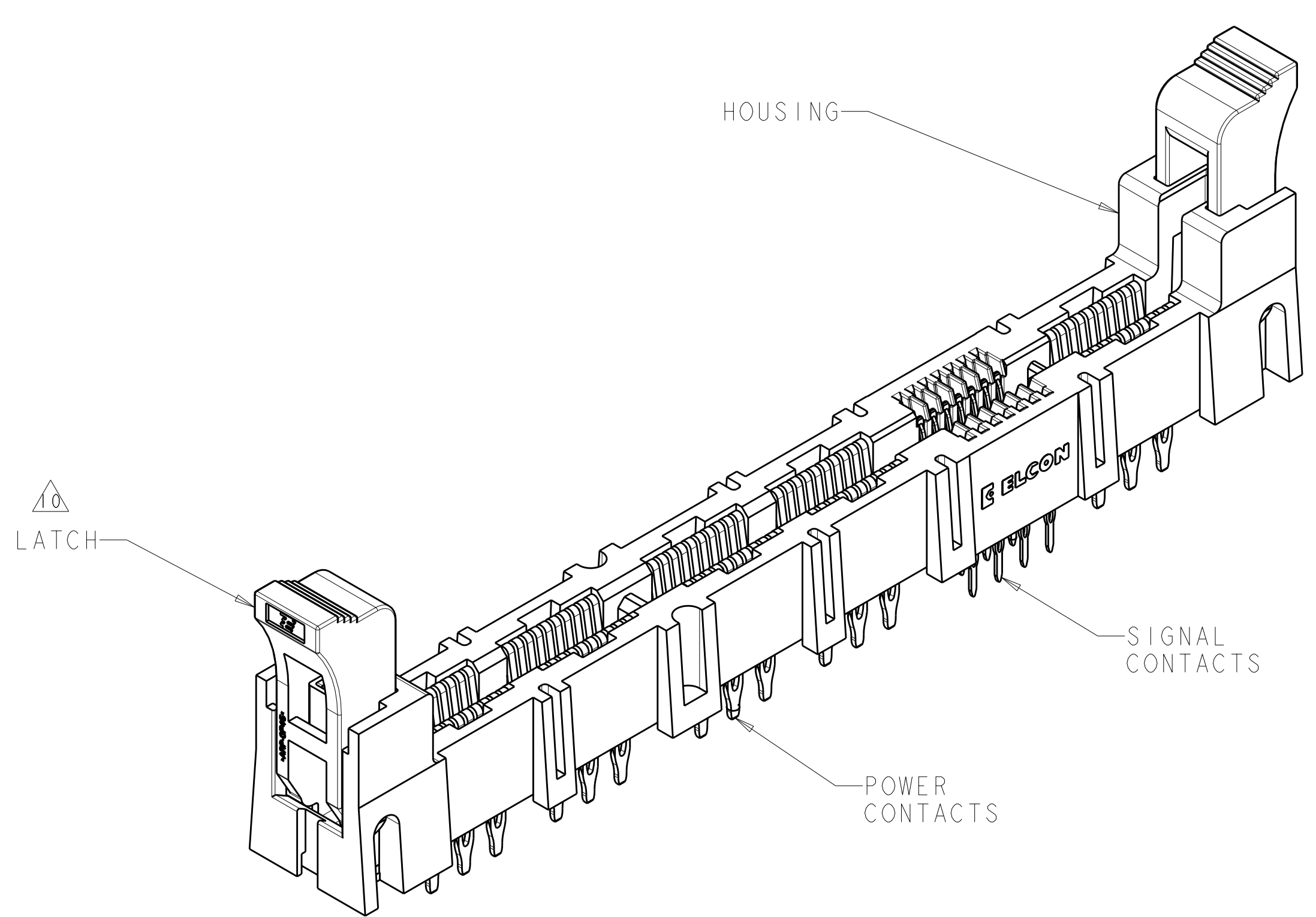

ISOMETRIC VIEW 1926168-2  
 SCALE 4:1

AS SHOWN	1926168-2
DESCRIPTION	PART NUMBER

DIMENSIONS: mm 9 PLC ±.5 1 PLC ±0.5 2 PLC ±0.25 3 PLC ±. 4 PLC ±. ANGLES ±. FINISH #2		TOLERANCES UNLESS OTHERWISE SPECIFIED: 9 PLC ±. 1 PLC ±0.5 2 PLC ±0.25 3 PLC ±. 4 PLC ±. ANGLES ±. FINISH #2		DWN R. GRZYBOWSKI 12 JUL 2006 CHK P. DAMATO 12 JUL 2006 APVD S. FLICKINGER 12 JUL 2006 NAME PRODUCT SPEC APPLICATION SPEC WEIGHT CUSTOMER DRAWING		Tyco Electronics Harrisburg, PA 17105-3608 CONNECTOR, SOCKET WITH LATCH COMPLIANT PRESS FIT MCE-P557 MINI CROWN EDGE SIZE CAGE CODE DRAWING NO A 100779 C=1926168 SCALE 5:1 SHEET 1 OF 4 REV A	
---	--	---	--	--	--	---	--

LOC	DIST	REV	DATE	BY	APPD
GP	00				

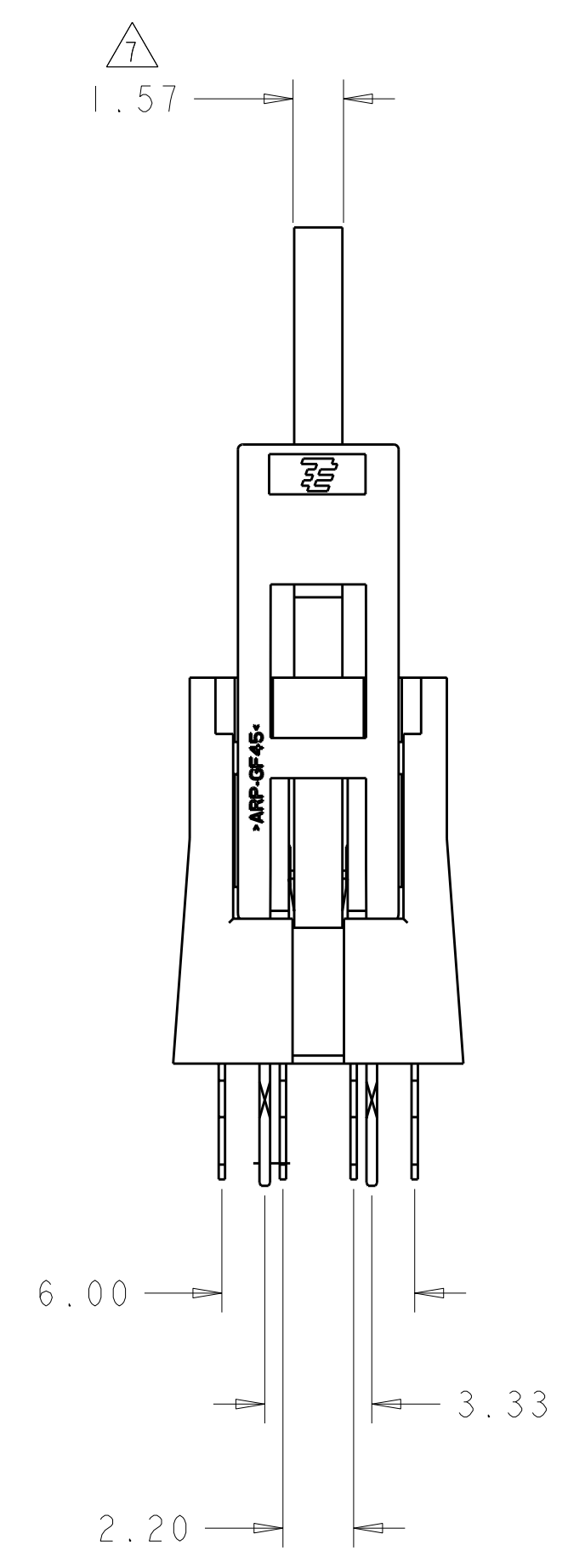
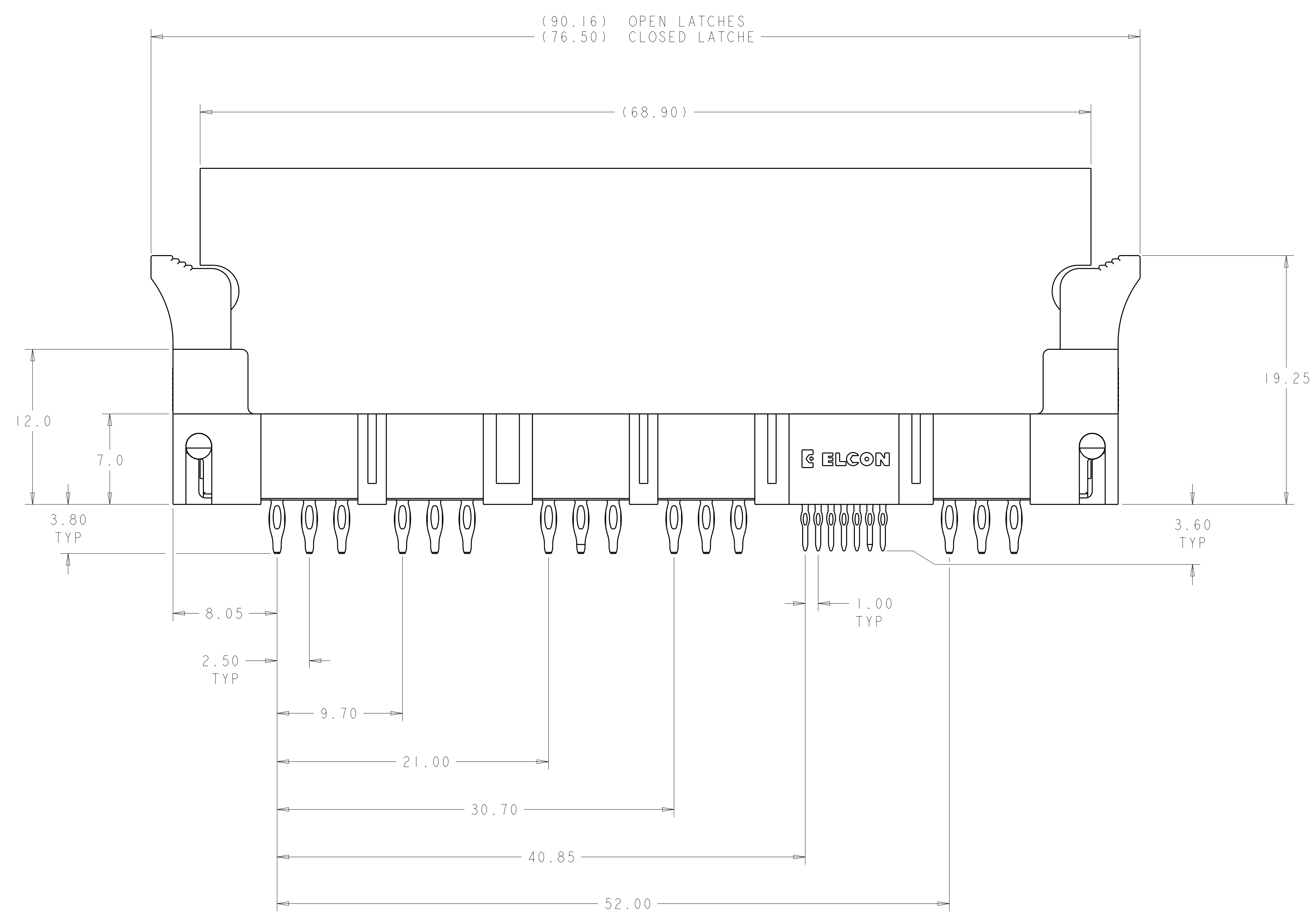
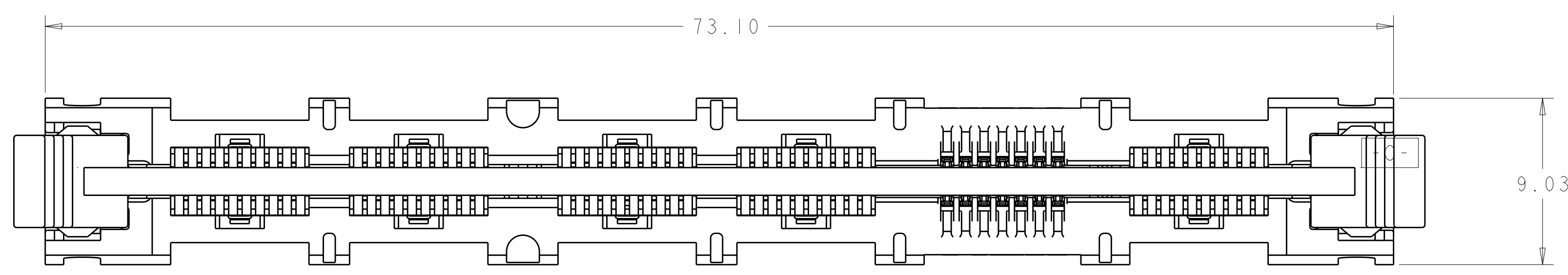

DIMENSIONS: mm 		TOLERANCES UNLESS OTHERWISE SPECIFIED: 9 PLC ± 1 PLC ±0.5 2 PLC ±0.25 3 PLC ± 4 PLC ± ANGLES ±#2 FINISH		DWN R. GRZYBOWSKI 12 JUL 2006 CHK P. DAMATO 12 JUL 2006 APVD S. FLICKINGER 12 JUL 2006 PRODUCT SPEC APPLICATION SPEC WEIGHT CUSTOMER DRAWING		Tyco Electronics Harrisburg, PA 17105-3608 NAME CONNECTOR, SOCKET WITH LATCH COMPLIANT PRESS FIT MCE-P5S7 MINI CROWN EDGE SIZE CAGE CODE DRAWING NO A100779C=1926168 SCALE 5:1 SHEET 2 OF 4 REV A	
-----------------------	--	--	--	--	--	---	--

LOC	DIST	REV	DATE	BY	APPD
GP	00				

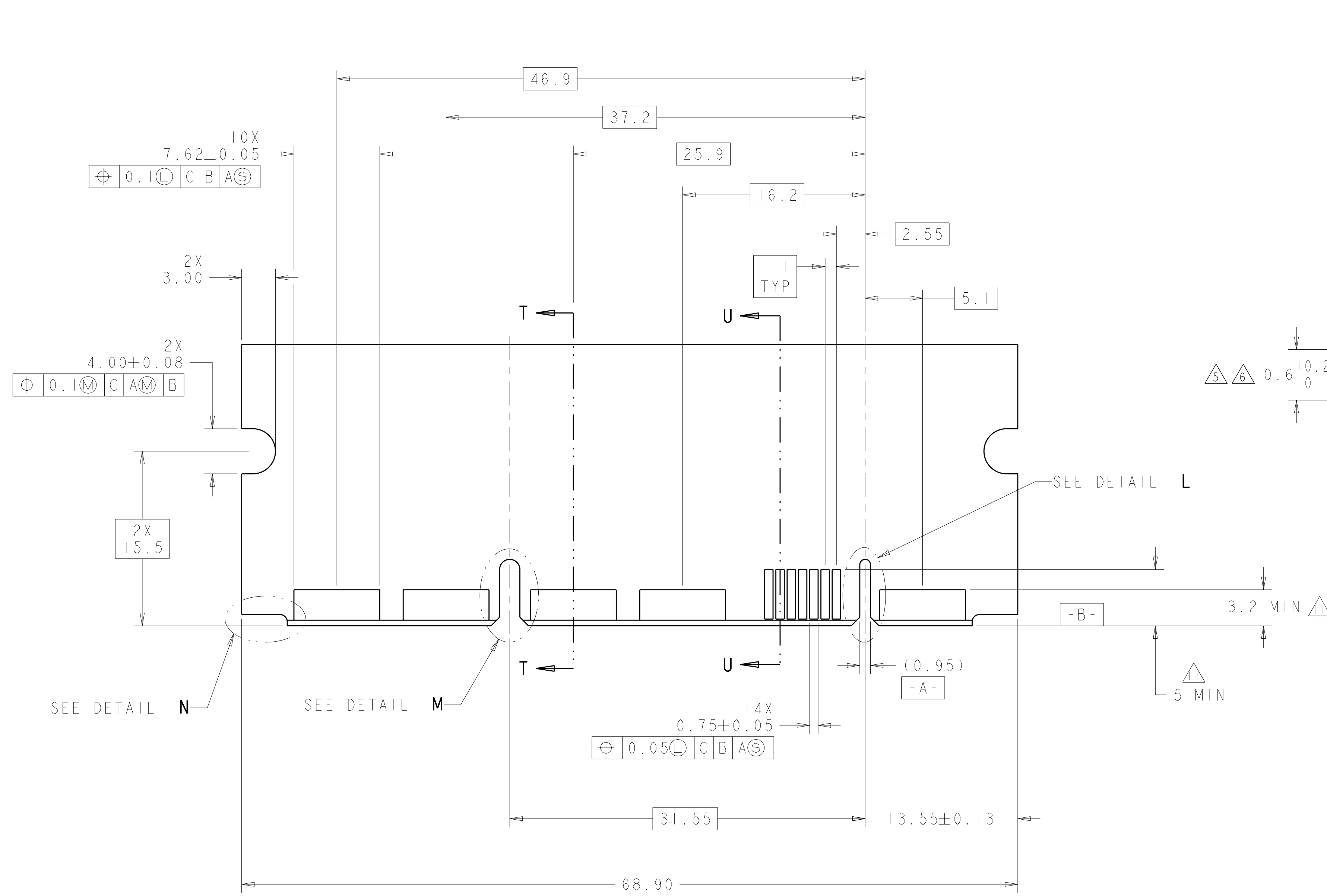

RECOMMENDED MATING BOARD  
SCALE 4:1

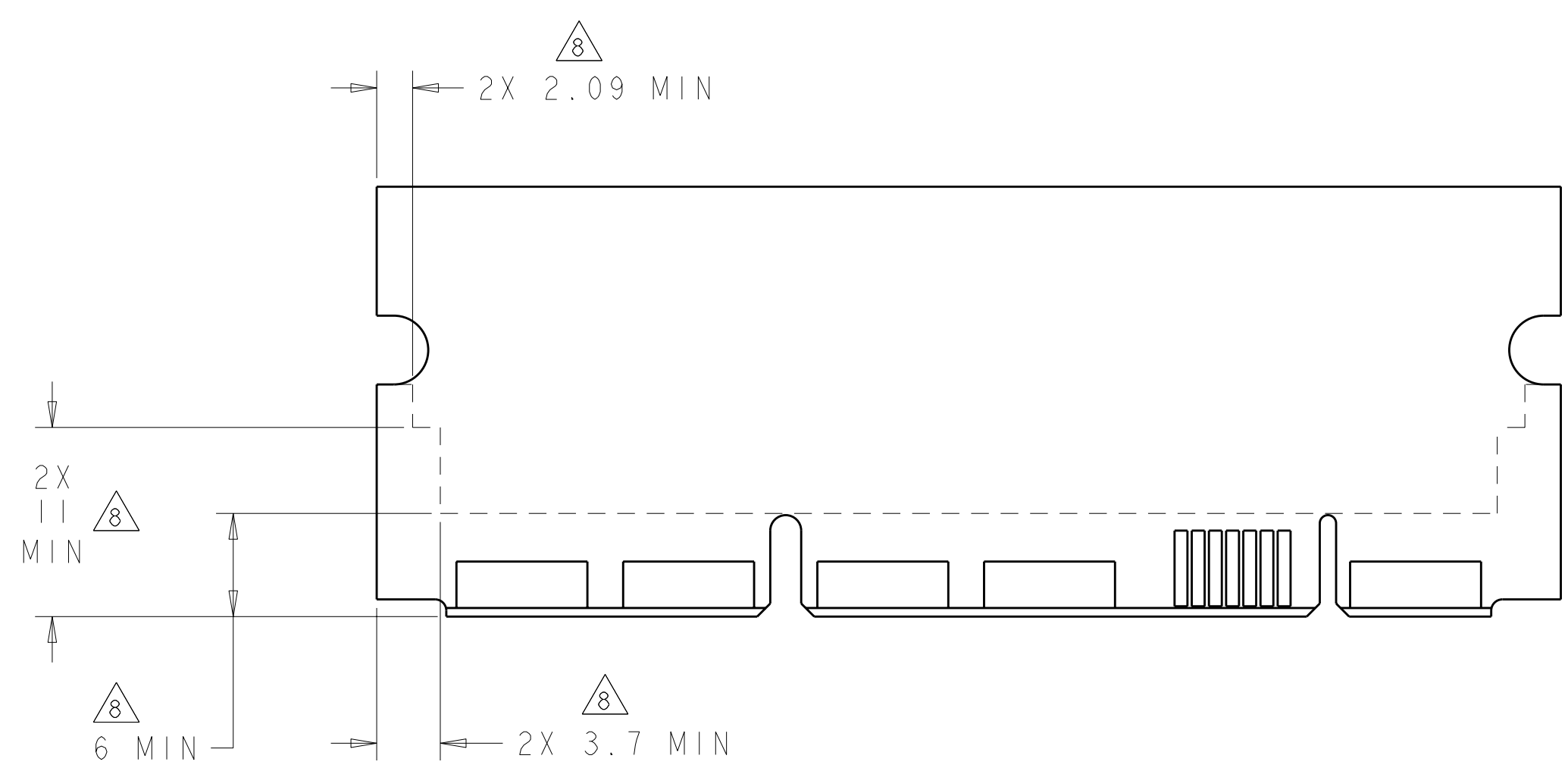

RCOMMENDED PC BOARD KEEP OUT AREA  
SCALE 3:1

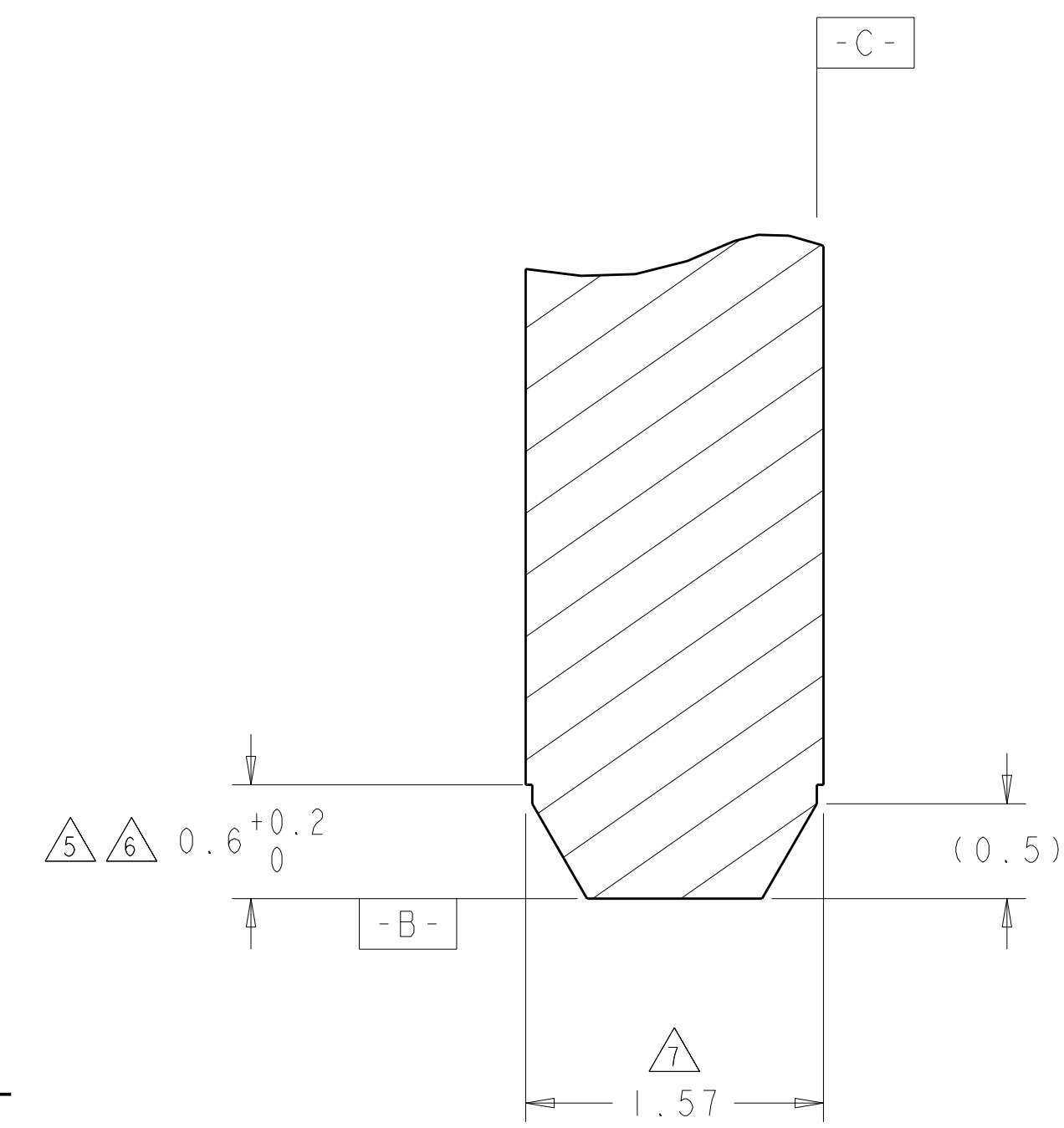

SECTION U-U  
SCALE 30:1

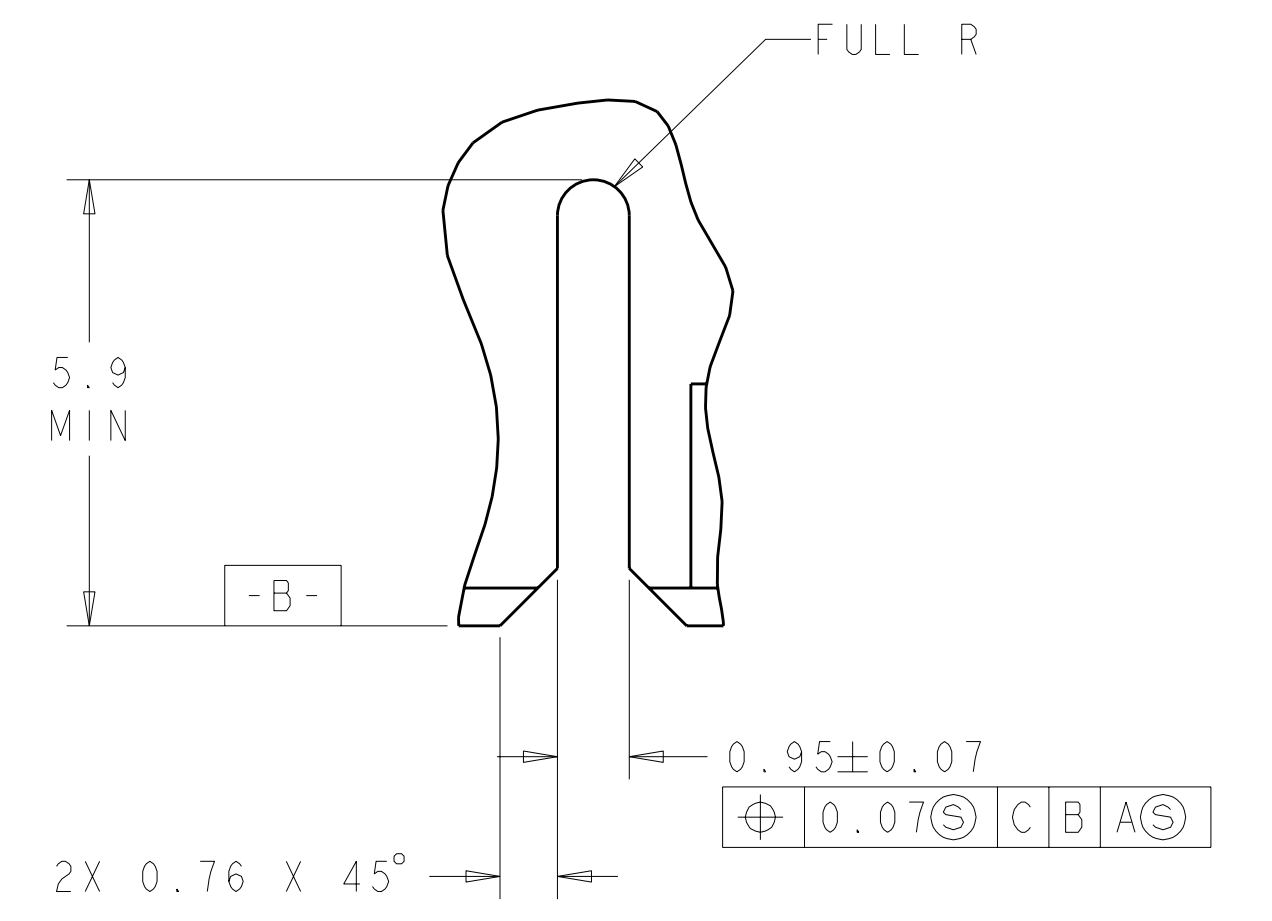

DETAIL L  
SCALE 10:1

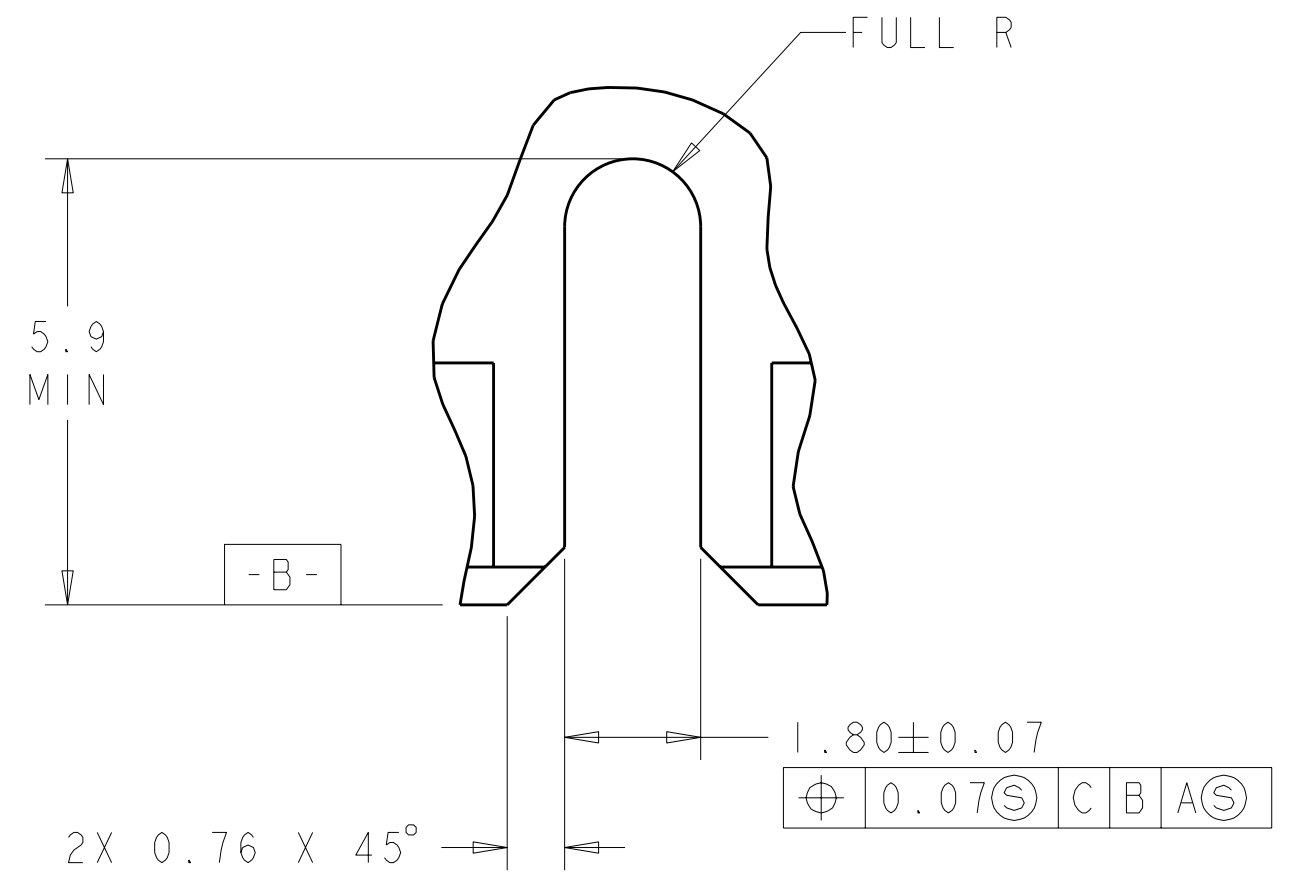

DETAIL M  
SCALE 10:1

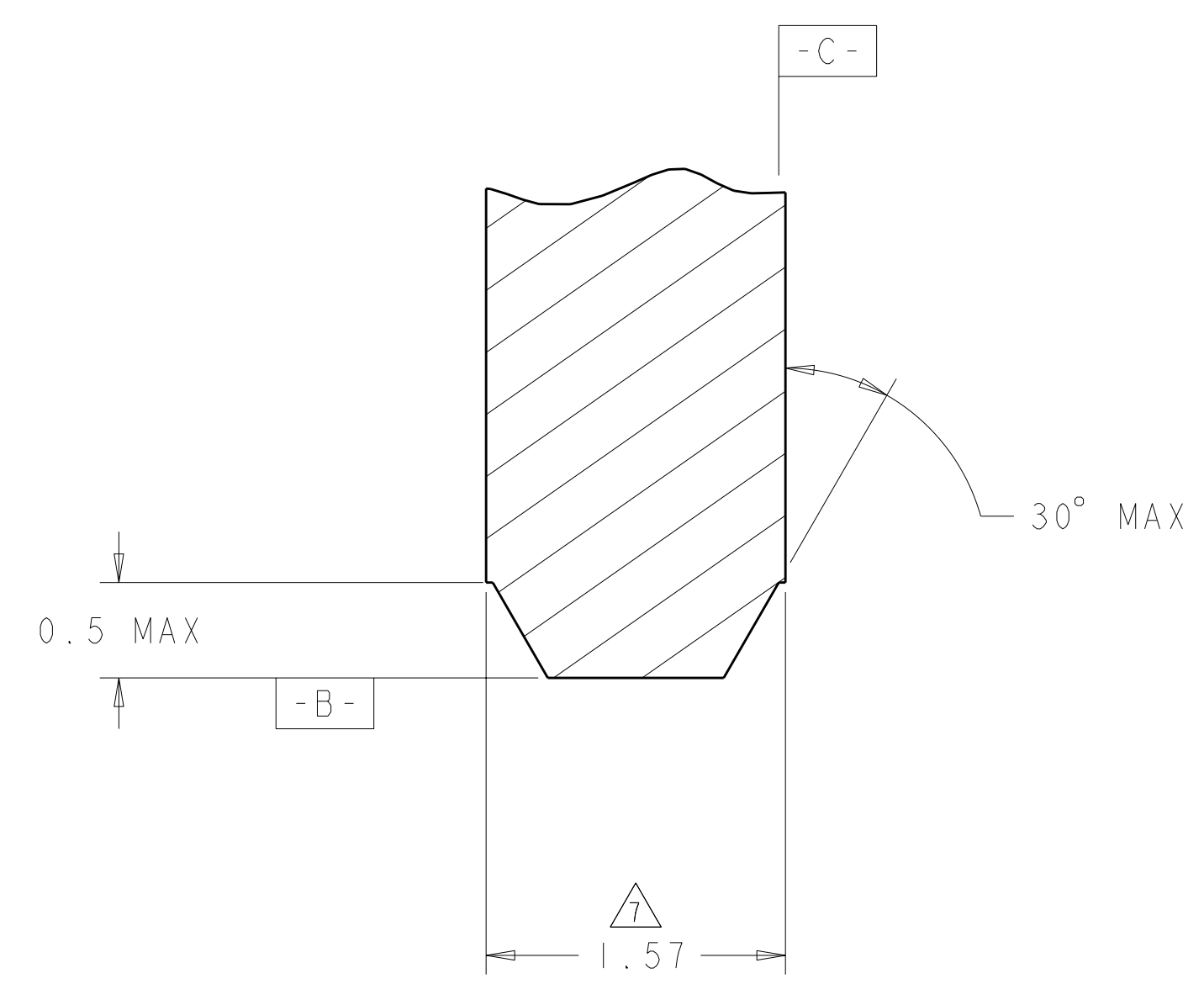

SECTION T-T  
SCALE 30:1

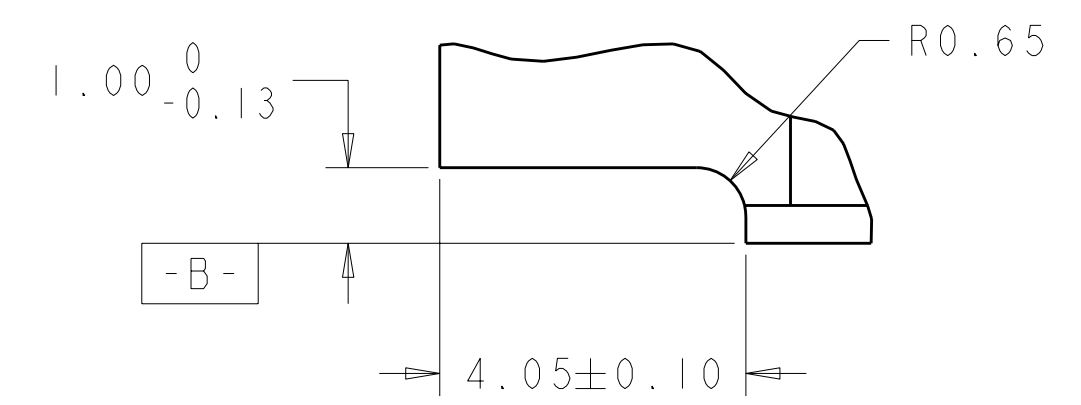

DETAIL N  
2X TYPICAL  
SCALE 10:1

DIMENSIONS: mm 		TOLERANCES UNLESS OTHERWISE SPECIFIED: 9 PLC ±.5 1 PLC ±0.5 2 PLC ±0.25 3 PLC ±.5 4 PLC ±.5 ANGLES ±.2 FINISH		DWN R. GRZYBOWSKI 12 JUL 2006 CHK P. DAMATO 12 JUL 2006 APVD S. FLICKINGER 12 JUL 2006 NAME PRODUCT SPEC APPLICATION SPEC WEIGHT CUSTOMER DRAWING		Tyco Electronics Harrisburg, PA 17105-3608 CONNECTOR, SOCKET WITH LATCH COMPLIANT PRESS FIT MCE-PS57 MINI CROWN EDGE SIZE CAGE CODE DRAWING NO A100779C=1926168 SCALE 5:1 SHEET 3 OF 4 REV A	
-----------------------	--	--	--	--	--	---	--

LOC	DIST	REV	DATE	BY	APPD
GP	00				
REVISIONS			DESCRIPTION	DATE	DWN
			SEE SHEET 1		

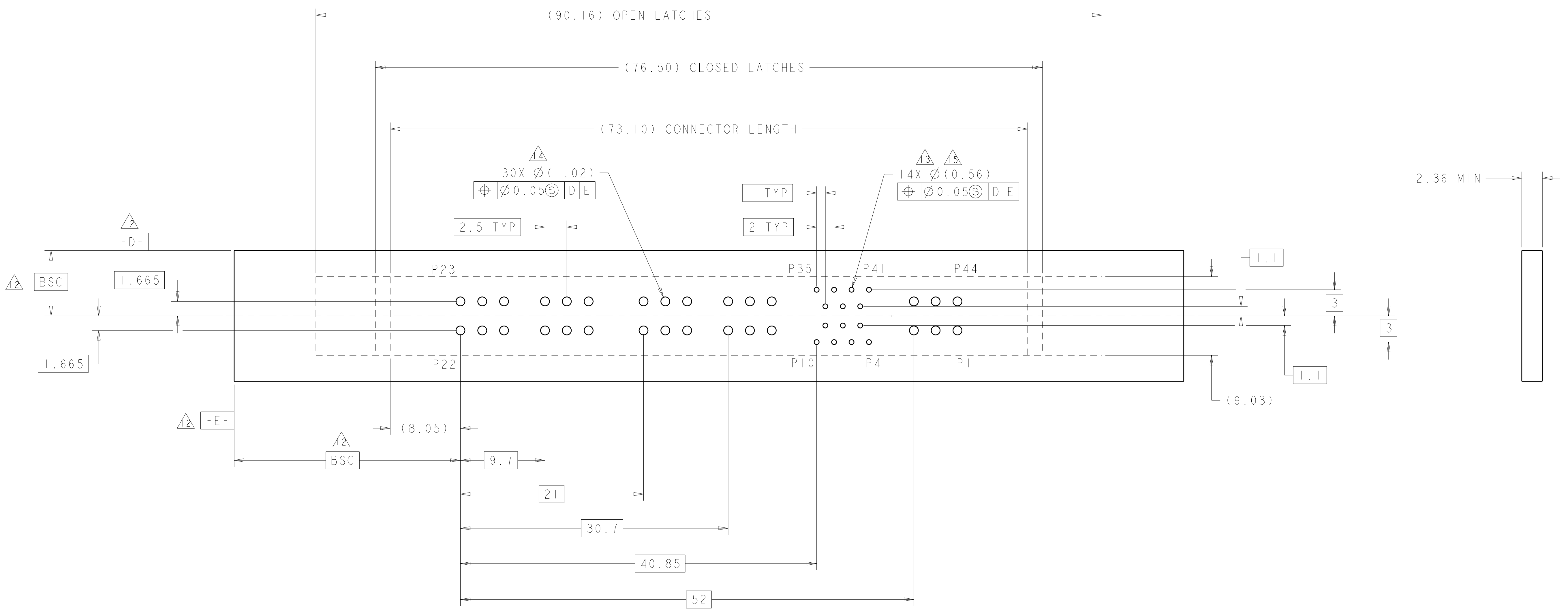

RECOMMENDED PRINTED CIRCUIT BOARD LAYOUT  
 SCALE 4:1

<small>THIS DRAWING IS UNPUBLISHED. RELEASED FOR PUBLICATION. 20                  © COPYRIGHT 20 BY TYCO ELECTRONICS CORPORATION. ALL RIGHTS RESERVED.</small>		DWN R. GRZYBOWSKI 12 JUL 2006 CHK P. DAMATO 12 JUL 2006 APVD S. FLICKINGER 12 JUL 2006	Tyco Electronics Harrisburg, PA 17105-3608
DIMENSIONS: mm 	TOLERANCES UNLESS OTHERWISE SPECIFIED: 9 PLC ± 1 PLC ±0.5 2 PLC ±0.25 3 PLC ± 4 PLC ± ANGLES ±#2 FINISH	NAME PRODUCT SPEC APPLICATION SPEC WEIGHT CUSTOMER DRAWING	NAME CONNECTOR, SOCKET WITH LATCH COMPLIANT PRESS FIT MCE-P5S7 MINI CROWN EDGE SIZE CAGE CODE DRAWING NO A 100779 C=1926168 RESTRICTED TO SCALE 5:1 SHEET 4 OF 4 REV A