



HIGH-SPEED 64K x 16 SYNCHRONOUS PIPELINED DUAL-PORT STATIC RAM

IDT709289L

Features

- ♦ True Dual-Ported memory cells which allow simultaneous access of the same memory location
- ♦ High-speed clock to data access
 - Commercial: 7.5/9/12ns (max.)
 - Industrial: 9ns (max.)
- ♦ Low-power operation
 - IDT709289L
 - Active: 1.2W (typ.)
 - Standby: 2.5mW (typ.)
- ♦ Flow-Through or Pipelined output mode on either Port via the FT/PIPEL pins
- ♦ Counter enable and reset features
- ♦ Dual chip enables allow for depth expansion without additional logic
- ♦ Full synchronous operation on both ports
 - 4ns setup to clock and 0ns hold on all control, data, and address inputs
 - Data input, address, and control registers
 - Fast 7.5ns clock to data out in the Pipelined output mode
 - Self-timed write allows fast cycle time
 - 12ns cycle time, 83MHz operation in Pipelined output mode
- ♦ Separate upper-byte and lower-byte controls for multiplexed bus and bus matching compatibility
- ♦ TTL-compatible, single 5V (±10%) power supply
- ♦ Industrial temperature range (–40°C to +85°C) is available for selected speeds
- ♦ Available in a 100-pin Thin Quad Flatpack (TQFP) package
- ♦ Green parts available, see ordering information

Functional Block Diagram

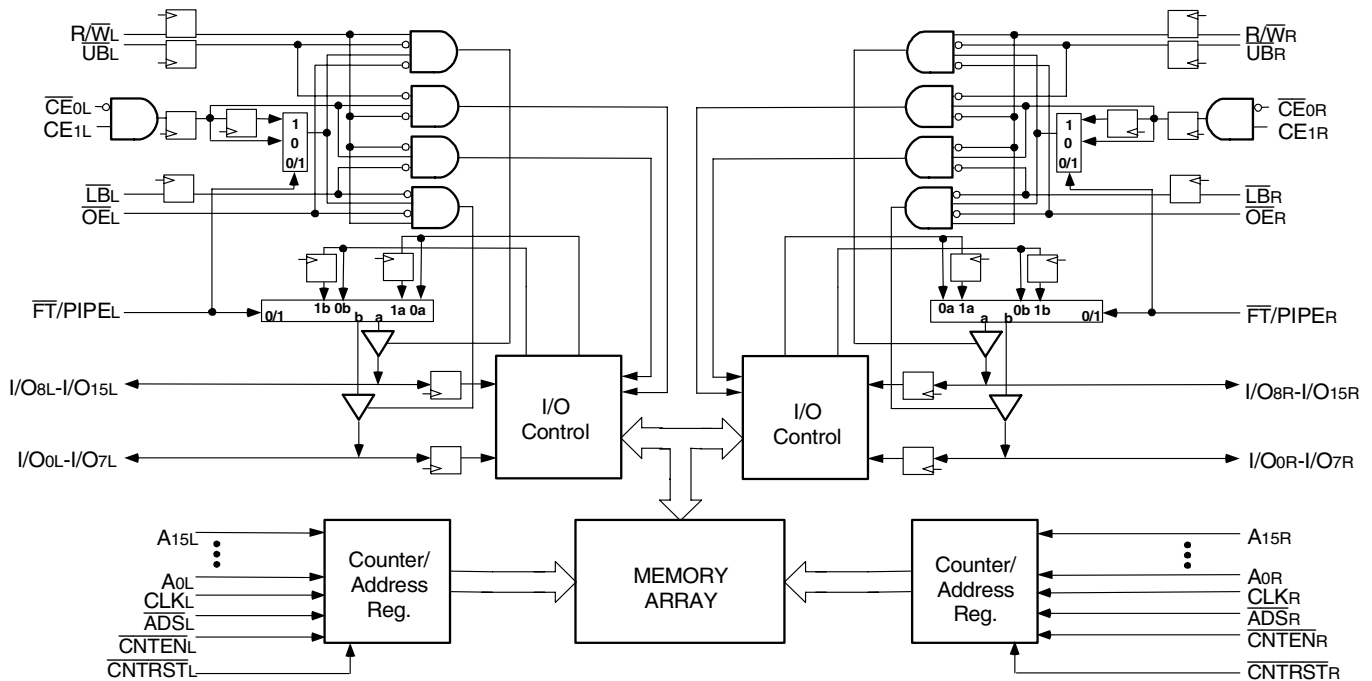

4842 drw 01

FEBRUARY 2015

Description

The IDT709289 is a high-speed 64K x 16 bit synchronous Dual-Port RAM. The memory array utilizes Dual-Port memory cells to allow simultaneous access of any address from both ports. Registers on control, data, and address inputs provide minimal setup and hold times. The timing latitude provided by this approach allows systems to be designed with very short cycle times.

With an input data register, the IDT709289 has been optimized for applications having unidirectional or bidirectional data flow in bursts. An automatic power down feature, controlled by $\overline{CE0}$ and $CE1$, permits the on-chip circuitry of each port to enter a very low standby power mode. Fabricated using CMOS high-performance technology, these devices typically operate on only 1.2W of power.

Pin Configurations^(1,2,3)

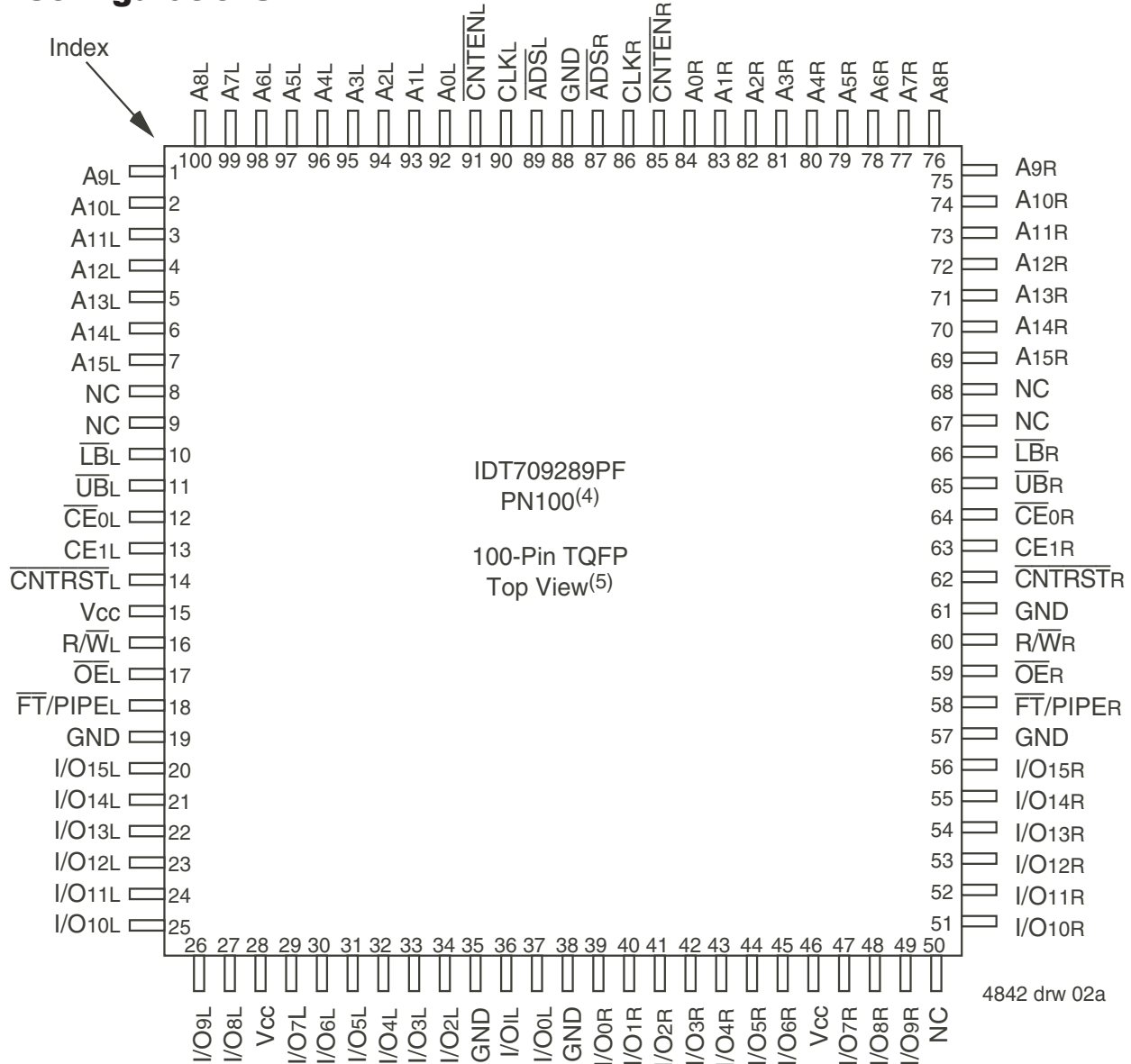

NOTES:

1. All Vcc pins must be connected to power supply.
2. All GND pins must be connected to ground.
3. Package body is approximately 14mm x 14mm x 1.4mm
4. This package code is used to reference the package diagram.
5. This text does not indicate orientation of the actual part-marking.

Pin Names

Left Port	Right Port	Names
$\overline{CE}_{0L}, CE_{1L}$	$\overline{CE}_{0R}, CE_{1R}$	Chip Enables
$R/\overline{W}L$	$R/\overline{W}R$	Read/Write Enable
$\overline{OE}L$	$\overline{OE}R$	Output Enable
A _{0L} - A _{15L}	A _{0R} - A _{15R}	Address
I/O _{0L} - I/O _{15L}	I/O _{0R} - I/O _{15R}	Data Input/Output
CLKL	CLKR	Clock
$\overline{UB}L$	$\overline{UB}R$	Upper Byte Select
$\overline{LB}L$	$\overline{LB}R$	Lower Byte Select
$\overline{ADS}L$	$\overline{ADS}R$	Address Strobe
$\overline{CNTEN}L$	$\overline{CNTEN}R$	Counter Enable
$\overline{CNTRST}L$	$\overline{CNTRST}R$	Counter Reset
$\overline{FT}/PIPEL$	$\overline{FT}/PIPER$	Flow-Through/Pipeline
V _{CC}		Power
GND		Ground

4842 tbl 01

Truth Table I—Read/Write and Enable Control^(1,2,3)

\overline{OE}	CLK	\overline{CE}_0	CE ₁	\overline{UB}	\overline{LB}	R/ \overline{W}	Upper Byte I/O ₈₋₁₅	Lower Byte I/O ₀₋₇	Mode
X	↑	H	X	X	X	X	High-Z	High-Z	Deselected—Power Down
X	↑	X	L	X	X	X	High-Z	High-Z	Deselected—Power Down
X	↑	L	H	H	H	X	High-Z	High-Z	Both Bytes Deselected
X	↑	L	H	L	H	L	DATA _{IN}	High-Z	Write to Upper Byte Only
X	↑	L	H	H	L	L	High-Z	DATA _{IN}	Write to Lower Byte Only
X	↑	L	H	L	L	L	DATA _{IN}	DATA _{IN}	Write to Both Bytes
L	↑	L	H	L	H	H	DATA _{OUT}	High-Z	Read Upper Byte Only
L	↑	L	H	H	L	H	High-Z	DATA _{OUT}	Read Lower Byte Only
L	↑	L	H	L	L	H	DATA _{OUT}	DATA _{OUT}	Read Both Bytes
H	X	L	H	L	L	X	High-Z	High-Z	Outputs Disabled

4842 tbl 02

NOTES:

- "H" = V_{IH}, "L" = V_{IL}, "X" = Don't Care.
- ADS, CNTEN, CNTRST = X.
- \overline{OE} is an asynchronous input signal.

Truth Table II—Address Counter Control^(1,2,6)

Address	Previous Address	Addr Used	CLK	\overline{ADS}	\overline{CNTEN}	\overline{CNRST}	I/O ⁽⁶⁾	Mode
X	X	0	↑	X	X	L	D/O(0)	Counter Reset to Address 0
An	X	An	↑	L ⁽⁴⁾	X	H	D/O(n)	External Address Loaded into Counter
An	Ap	Ap	↑	H	H	H	D/O(p)	External Address Blocked—Counter Disabled (Ap reused)
X	Ap	Ap + 1	↑	H	L ⁽⁵⁾	H	D/O(p+1)	Counter Enable—Internal Address Generation

4842 tbl 03

NOTES:

- "H" = V_{IH}, "L" = V_{IL}, "X" = Don't Care.
- $\overline{CE_0}$, \overline{LB} , \overline{UB} , and \overline{OE} = V_{IL}; CE₁ and $\overline{R\overline{W}}$ = V_{IH}.
- Outputs configured in Flow-Through Output mode: if outputs are in Pipelined mode the data out will be delayed by one cycle.
- \overline{ADS} is independent of all other signals including $\overline{CE_0}$, CE₁, \overline{UB} and \overline{LB} .
- The address counter advances if \overline{CNTEN} = V_{IL} on the rising edge of CLK, regardless of all other signals including $\overline{CE_0}$, CE₁, \overline{UB} and \overline{LB} .
- While an external address is being loaded (\overline{ADS} = V_{IL}), $\overline{R\overline{W}}$ = V_{IH} is recommended to ensure data is not written arbitrarily.

Recommended Operating Temperature and Supply Voltage

Grade	Ambient Temperature ⁽²⁾	GND	V _{CC}
Commercial	0°C to +70°C	0V	5.0V ± 10%
Industrial	-40°C to +85°C	0V	5.0V ± 10%

4842 tbl 04

NOTES:

- This is the parameter T_A. This is the "instant on" case temperature.

Recommended DC Operating Conditions

Symbol	Parameter	Min.	Typ.	Max.	Unit
V _{CC}	Supply Voltage	4.5	5.0	5.5	V
GND	Ground	0	0	0	V
V _{IH}	Input High Voltage	2.2	—	6.0 ⁽¹⁾	V
V _{IL}	Input Low Voltage	-0.5 ⁽²⁾	—	0.8	V

4842 tbl 05

NOTES:

- V_{TERM} must not exceed V_{CC} + 10%.
- V_{IL} ≥ -1.5V for pulse width less than 10ns.

Absolute Maximum Ratings⁽¹⁾

Symbol	Rating	Commercial & Industrial	Unit
V _{TERM} ⁽²⁾	Terminal Voltage with Respect to GND	-0.5 to +7.0	V
T _{BIAS}	Temperature Under Bias	-55 to +125	°C
T _{STG}	Storage Temperature	-65 to +150	°C
I _{OUT}	DC Output Current	50	mA

4842 tbl 06

NOTES:

- Stresses greater than those listed under ABSOLUTE MAXIMUM RATINGS may cause permanent damage to the device. This is a stress rating only and functional operation of the device at these or any other conditions above those indicated in the operational sections of this specification is not implied. Exposure to absolute maximum rating conditions for extended periods may affect reliability.
- V_{TERM} must not exceed V_{CC} + 10% for more than 25% of the cycle time or 10ns maximum, and is limited to ≤ 20mA for the period of V_{TERM} ≥ V_{CC} + 10%.

Capacitance⁽¹⁾**(T_A = +25°C, f = 1.0MHz)**

Symbol	Parameter	Conditions ⁽²⁾	Max.	Unit
C _{IN}	Input Capacitance	V _{IN} = 3dV	9	pF
C _{OUT} ⁽³⁾	Output Capacitance	V _{OUT} = 3dV	10	pF

4842 tbl 07

NOTES:

- These parameters are determined by device characterization, but are not production tested.
- 3dV references the interpolated capacitance when the input and output switch from 0V to 3V or from 3V to 0V.
- C_{OUT} also references C_{I/O}.

DC Electrical Characteristics Over the Operating Temperature Supply Voltage Range ($V_{CC} = 5.0V \pm 10\%$)

Symbol	Parameter	Test Conditions	709289L		Unit
			Min.	Max.	
$ I_{L} $	Input Leakage Current ⁽¹⁾	$V_{CC} = 5.5V, V_{IN} = 0V$ to V_{CC}	—	5	μA
$ I_{L0} $	Output Leakage Current	$\overline{CE}_0 = V_{IH}$ or $CE_1 = V_{IL}, V_{OUT} = 0V$ to V_{CC}	—	5	μA
V_{OL}	Output Low Voltage	$I_{OL} = +4mA$	—	0.4	V
V_{OH}	Output High Voltage	$I_{OH} = -4mA$	2.4	—	V

4842 tbl 08

NOTE:

- At $V_{CC} \leq 2.0V$ input leakages are undefined.

DC Electrical Characteristics Over the Operating Temperature and Supply Voltage Range⁽³⁾ ($V_{CC} = 5V \pm 10\%$)

Symbol	Parameter	Test Condition	Version	709289L7 Com'l Only		709289L9 Com'l & Ind		709289L12 Com'l Only		Unit
				Typ. ⁽⁴⁾	Max.	Typ. ⁽⁴⁾	Max.	Typ. ⁽⁴⁾	Max.	
ICC	Dynamic Operating Current (Both Ports Active)	\overline{CE}_L and $\overline{CE}_R = V_{IL}$ Outputs Disabled $f = f_{MAX}^{(1)}$	COM'L L	275	465	250	400	230	355	mA
			IND L	—	—	300	430	—	—	
ISB1	Standby Current (Both Ports - TTL Level Inputs)	$\overline{CE}_L = \overline{CE}_R = V_{IH}$ $f = f_{MAX}^{(1)}$	COM'L L	95	150	80	135	70	110	mA
			IND L	—	—	95	160	—	—	
ISB2	Standby Current (One Port - TTL Level Inputs)	$\overline{CE}^A = V_{IL}$ and $\overline{CE}^B = V_{IH}^{(2)}$ Active Port Outputs Disabled, $f = f_{MAX}^{(1)}$	COM'L L	200	295	175	275	150	240	mA
			IND L	—	—	195	295	—	—	
ISB3	Full Standby Current (Both Ports - CMOS Level Inputs)	Both Ports \overline{CE}_R and $\overline{CE}_L \geq V_{CC} - 0.2V$ $V_{IN} \geq V_{CC} - 0.2V$ or $V_{IN} \leq 0.2V, f = 0^{(2)}$	COM'L L	0.5	3.0	0.5	3.0	0.5	3.0	mA
			IND L	—	—	0.5	6.0	—	—	
ISB4	Full Standby Current (One Port - CMOS Level Inputs)	$\overline{CE}^A \leq 0.2V$ and $\overline{CE}^B \geq V_{CC} - 0.2V^{(5)}$ $V_{IN} \geq V_{CC} - 0.2V$ or $V_{IN} \leq 0.2V$, Active Port Outputs Disabled, $f = f_{MAX}^{(1)}$	COM'L L	190	290	170	270	140	225	mA
			IND L	—	—	190	290	—	—	

4842 tbl 09

NOTES:

- At $f = f_{MAX}$, address and control lines (except Output Enable) are cycling at the maximum frequency clock cycle of $1/t_{cyc}$, using "AC TEST CONDITIONS" at input levels of GND to 3V.
- $f = 0$ means no address, clock, or control lines change. Applies only to input at CMOS level standby.
- Port "A" may be either left or right port. Port "B" is the opposite from port "A".
- $V_{CC} = 5V, T_A = 25^\circ C$ for Typ, and are not production tested. $I_{CC DC}(f=0) = 150mA$ (Typ).
- $\overline{CE}_X = V_{IL}$ means $\overline{CE}_{0X} = V_{IL}$ and $CE_{1X} = V_{IH}$
 $\overline{CE}_X = V_{IH}$ means $\overline{CE}_{0X} = V_{IH}$ or $CE_{1X} = V_{IL}$
 $\overline{CE}_X \leq 0.2V$ means $\overline{CE}_{0X} \leq 0.2V$ and $CE_{1X} \geq V_{CC} - 0.2V$
 $\overline{CE}_X \geq V_{CC} - 0.2V$ means $\overline{CE}_{0X} \geq V_{CC} - 0.2V$ or $CE_{1X} \leq 0.2V$
"X" represents "L" for left port or "R" for right port.

AC Test Conditions

Input Pulse Levels	GND to 3.0V
Input Rise/Fall Times	3ns Max.
Input Timing Reference Levels	1.5V
Output Reference Levels	1.5V
Output Load	Figures 1,2 and 3

4842 tbl 10

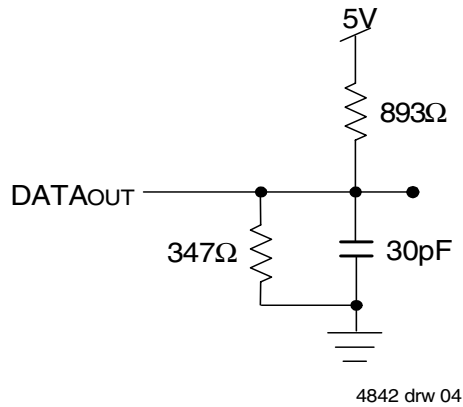

Figure 1. AC Output Test load.

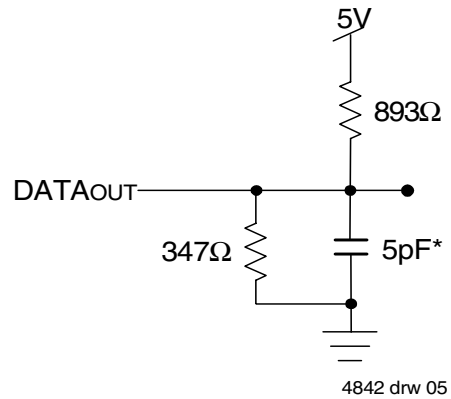

Figure 2. Output Test Load
(For tCKLZ, tCKHZ, tOLZ, and tOHZ).
*Including scope and jig.

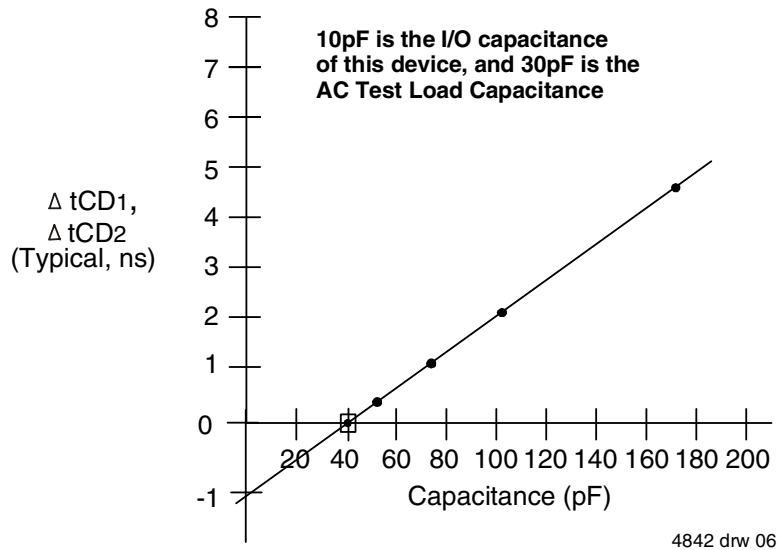

Figure 3. Typical Output Derating (Lumped Capacitive Load).

AC Electrical Characteristics Over the Operating Temperature Range (Read and Write Cycle Timing)⁽³⁾ ($V_{CC} = 5V \pm 10\%$, $T_A = 0^{\circ}C$ to $+70^{\circ}C$)

Symbol	Parameter	709289L7 Com'l Only		709289L9 Com'l & Ind		709289L12 Com'l Only		Unit
		Min.	Max.	Min.	Max.	Min.	Max.	
t _{CYC1}	Clock Cycle Time (Flow-Through) ⁽²⁾	22	—	25	—	30	—	ns
t _{CYC2}	Clock Cycle Time (Pipelined) ⁽²⁾	12	—	15	—	20	—	ns
t _{CH1}	Clock High Time (Flow-Through) ⁽²⁾	7.5	—	12	—	12	—	ns
t _{CL1}	Clock Low Time (Flow-Through) ⁽²⁾	7.5	—	12	—	12	—	ns
t _{CH2}	Clock High Time (Pipelined) ⁽²⁾	5	—	6	—	8	—	ns
t _{CL2}	Clock Low Time (Pipelined) ⁽²⁾	5	—	6	—	8	—	ns
t _R	Clock Rise Time	—	3	—	3	—	3	ns
t _F	Clock Fall Time	—	3	—	3	—	3	ns
t _{SA}	Address Setup Time	4	—	4	—	4	—	ns
t _{HA}	Address Hold Time	0	—	1	—	1	—	ns
t _{SC}	Chip Enable Setup Time	4	—	4	—	4	—	ns
t _{HC}	Chip Enable Hold Time	0	—	1	—	1	—	ns
t _{SB}	Byte Enable Setup Time	4	—	4	—	4	—	ns
t _{HB}	Byte Enable Hold Time	0	—	1	—	1	—	ns
t _{SW}	R/W Setup Time	4	—	4	—	4	—	ns
t _{HW}	R/W Hold Time	0	—	1	—	1	—	ns
t _{SD}	Input Data Setup Time	4	—	4	—	4	—	ns
t _{HD}	Input Data Hold Time	0	—	1	—	1	—	ns
t _{SAD}	\overline{ADS} Setup Time	4	—	4	—	4	—	ns
t _{HAD}	\overline{ADS} Hold Time	0	—	1	—	1	—	ns
t _{SCN}	\overline{CNTEN} Setup Time	4	—	4	—	4	—	ns
t _{HCN}	\overline{CNTEN} Hold Time	0	—	1	—	1	—	ns
t _{SRST}	\overline{CNRST} Setup Time	4	—	4	—	4	—	ns
t _{HRST}	\overline{CNRST} Hold Time	0	—	1	—	1	—	ns
t _{OE}	Output Enable to Data Valid	—	9	—	12	—	12	ns
t _{OLZ}	Output Enable to Output Low-Z ⁽¹⁾	2	—	2	—	2	—	ns
t _{OHZ}	Output Enable to Output High-Z ⁽¹⁾	1	7	1	7	1	7	ns
t _{CD1}	Clock to Data Valid (Flow-Through) ⁽²⁾	—	18	—	20	—	25	ns
t _{CD2}	Clock to Data Valid (Pipelined) ⁽²⁾	—	7.5	—	9	—	12	ns
t _{DC}	Data Output Hold After Clock High	2	—	2	—	2	—	ns
t _{CKHZ}	Clock High to Output High-Z ⁽¹⁾	2	9	2	9	2	9	ns
t _{CKLZ}	Clock High to Output Low-Z ⁽¹⁾	2	—	2	—	2	—	ns
Port-to-Port Delay								
t _{OWDD}	Write Port Clock High to Read Data Delay	—	28	—	35	—	40	ns
t _{OCS}	Clock-to-Clock Setup Time	—	10	—	15	—	15	ns

NOTES:

4842 tbl 11

- Transition is measured 0mV from Low or High-impedance voltage with the Output Test Load (Figure 2). This parameter is guaranteed by device characterization, but is not production tested.
- The Pipelined output parameters (t_{CYC2}, t_{CD2}) to either the Left or Right ports when $\overline{FT}/PIPE = V_{IH}$. Flow-Through parameters (t_{CYC1}, t_{CD1}) apply when $\overline{FT}/PIPE = V_{IL}$ for that port.
- All input signals are synchronous with respect to the clock except for the asynchronous Output Enable (\overline{OE}), $\overline{FT}/PIPE_R$ and $\overline{FT}/PIPE_L$.

Timing Waveform of Read Cycle for Flow-Through Output ($\overline{FT}/PIPE"x" = V_{IL}$)^(3,7)

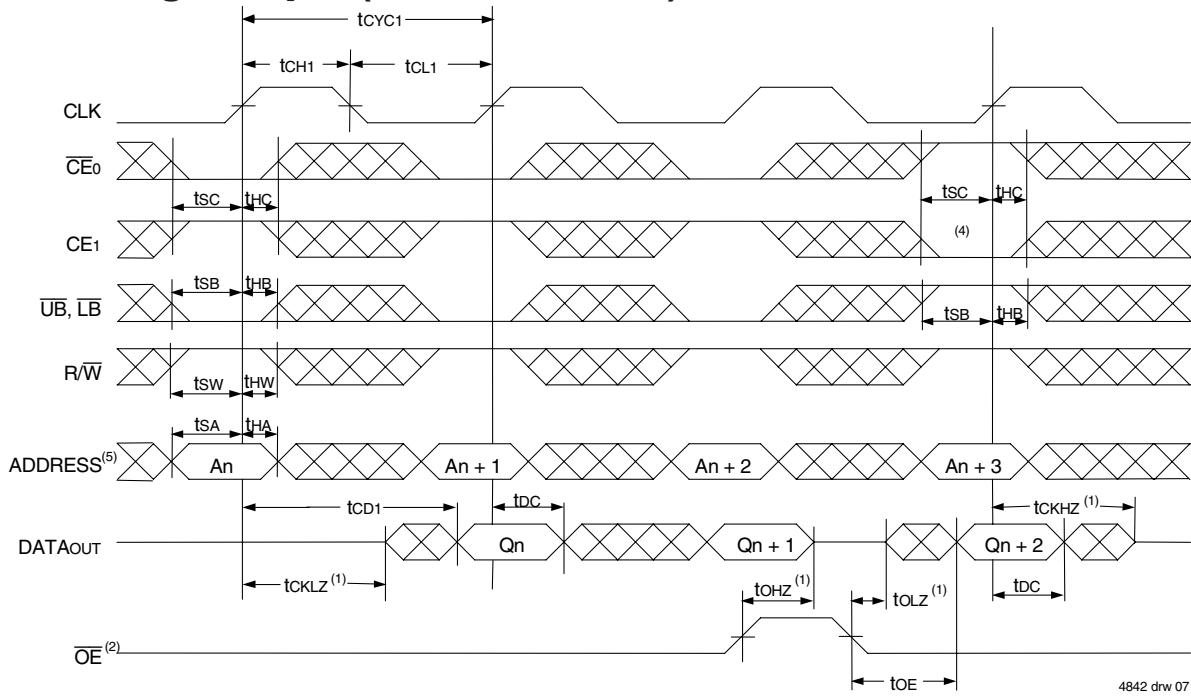

4842 drw 07

Timing Waveform of Read Cycle for Pipelined Operation ($\overline{FT}/PIPE"x" = V_{IH}$)^(3,7)

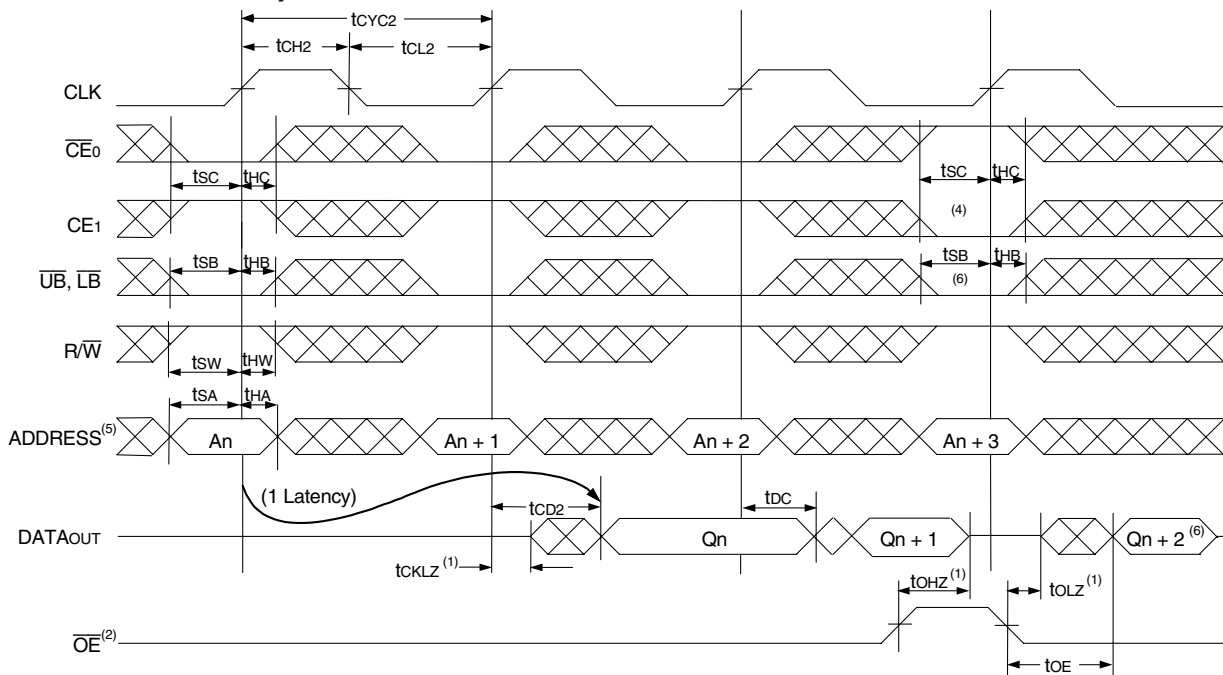

4842 drw 08

NOTES:

1. Transition is measured 0mV from Low or High-impedance voltage with the Output Test Load (Figure 2).
2. \overline{OE} is asynchronously controlled; all other inputs are synchronous to the rising clock edge.
3. $ADS = V_{IL}$, $CNTEN$ and $CNTRST = V_{IH}$.
4. The output is disabled (High-Impedance state) by $\overline{CE0} = V_{IH}$, $CE1 = V_{IL}$, $\overline{UB} = V_{IH}$, or $\overline{LB} = V_{IH}$ following the next rising edge of the clock. Refer to Truth Table 1.
5. Addresses do not have to be accessed sequentially since $ADS = V_{IL}$ constantly loads the address on the rising edge of the CLK; numbers are for reference use only.
6. If \overline{UB} or \overline{LB} was HIGH, then the Upper Byte and/or Lower Byte of DATAOUT for Q_{n+2} would be disabled (High-Impedance state).
7. "X" here denotes Left or Right port. The diagram is with respect to that port.

Timing Waveform of a Bank Select Pipelined Read(1,2)

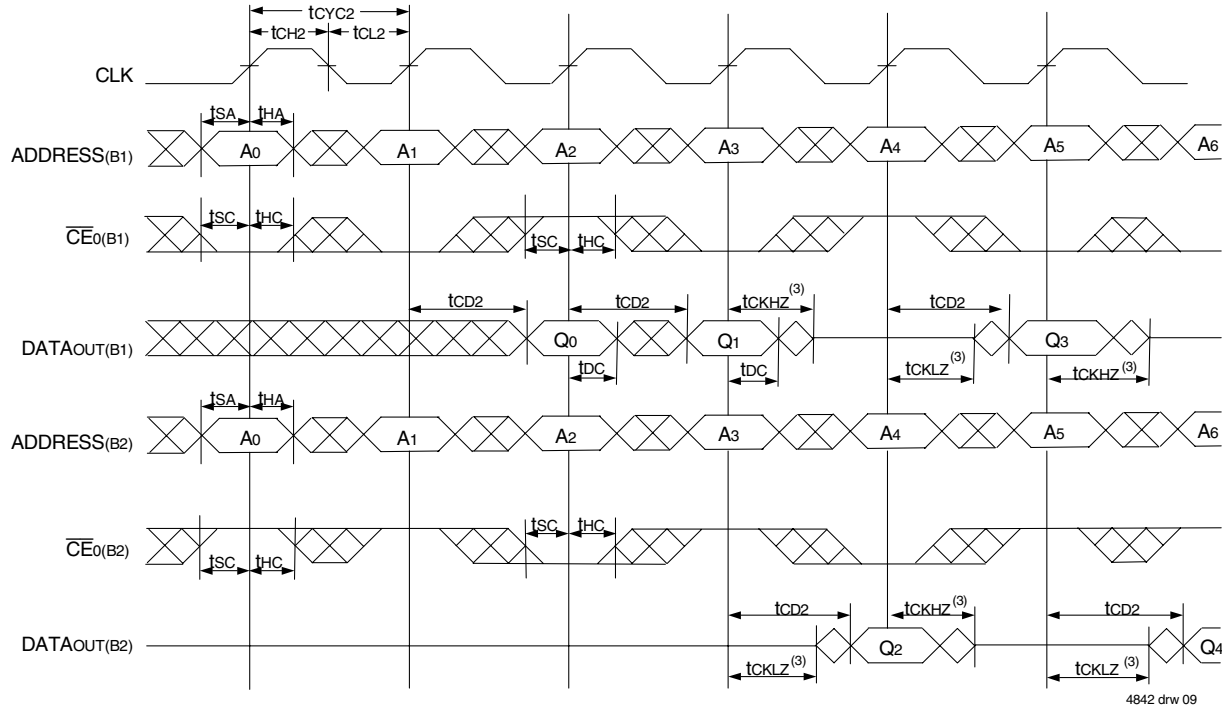

Timing Waveform of Write with Port-to-Port Flow-Through Read(4,5,7)

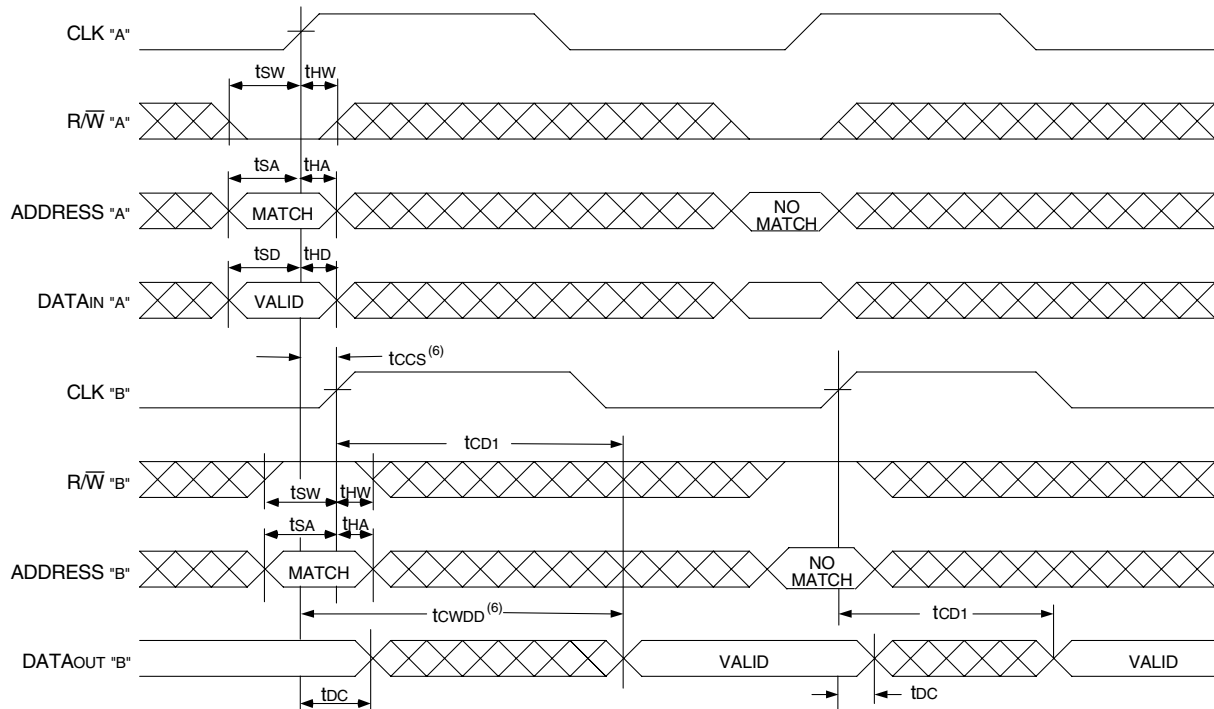

NOTES:

1. B1 Represents Bank #1; B2 Represents Bank #2. Each Bank consists of one IDT709289 for this waveform, and are setup for depth expansion in this example. ADDRESS_(B1) = ADDRESS_(B2) in this situation.
2. \overline{UB} , \overline{LB} , \overline{OE} , and $\overline{ADS} = V_{IL}$; $CE_{1(B1)}$, $CE_{1(B2)}$, R/\overline{W} , \overline{CNTEN} , and $\overline{CNTRST} = V_{IH}$.
3. Transition is measured 0mV from Low or High-impedance voltage with the Output Test Load (Figure 2).
4. \overline{CE}_0 , \overline{UB} , \overline{LB} , and $\overline{ADS} = V_{IL}$; CE_1 , \overline{CNTEN} , and $\overline{CNTRST} = V_{IH}$.
5. $\overline{OE} = V_{IL}$ for the Right Port, which is being read from. $\overline{OE} = V_{IH}$ for the Left Port, which is being written to.
6. If $t_{CCS} \leq$ maximum specified, then data from right port READ is not valid until the maximum specified for t_{CWDD} . If $t_{CCS} >$ maximum specified, then data from right port READ is not valid until $t_{CCS} + t_{CD1}$. t_{CWDD} does not apply in this case.
7. All timing is the same for both Left and Right ports. Port "A" may be either Left or Right port. Port "B" is the opposite from Port "A".

Timing Waveform of Pipelined Read-to-Write-to-Read ($\overline{OE} = V_{IL}$)⁽³⁾

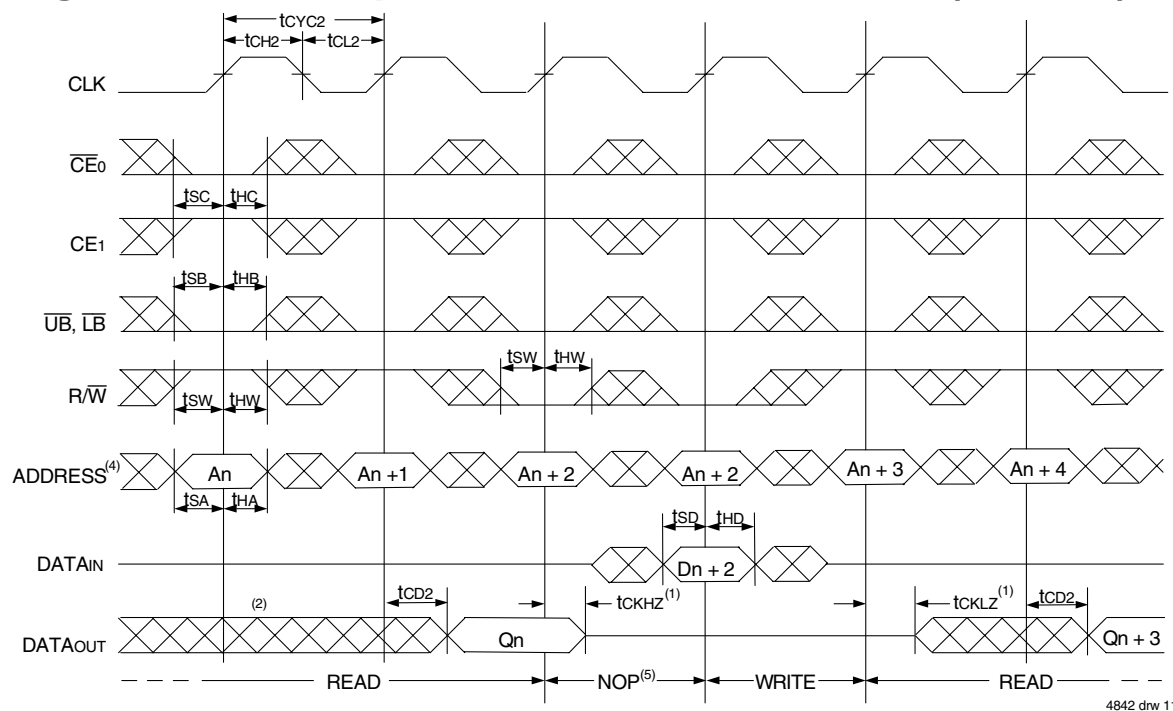

Timing Waveform of Pipelined Read-to-Write-to-Read (\overline{OE} Controlled)⁽³⁾

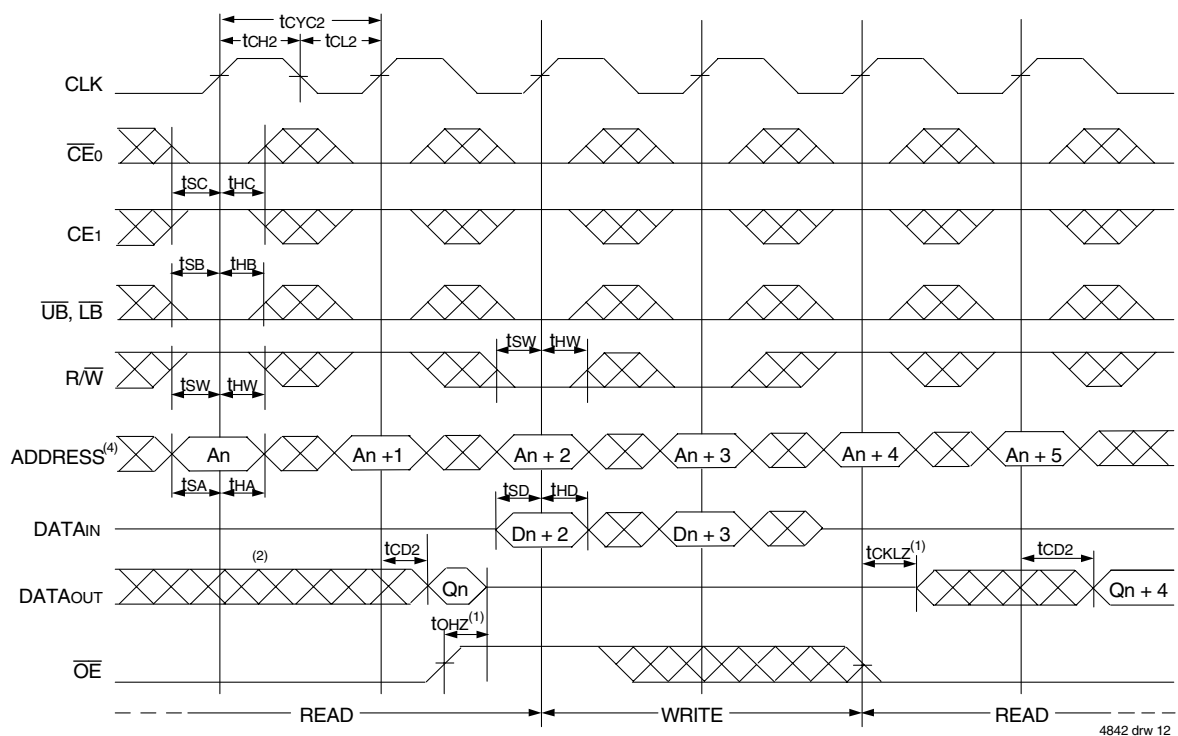

NOTES:

1. Transition is measured 0mV from Low or High-impedance voltage with the Output Test Load (Figure 2).
2. Output state (High, Low, or High-impedance) is determined by the previous cycle control signals.
3. \overline{CE}_0 , \overline{UB} , \overline{LB} , and $\overline{ADS} = V_{IL}$; CE1, \overline{CNTEN} , and $\overline{CNTRST} = V_{IH}$. "NOP" is "No Operation".
4. Addresses do not have to be accessed sequentially since $\overline{ADS} = V_{IL}$ constantly loads the address on the rising edge of the CLK; numbers are for reference use only.
5. "NOP" is "No Operation." Data in memory at the selected address may be corrupted and should be re-written to guarantee data integrity.

Timing Waveform of Flow-Through Read-to-Write-to-Read ($\overline{OE} = V_{IL}$)⁽³⁾

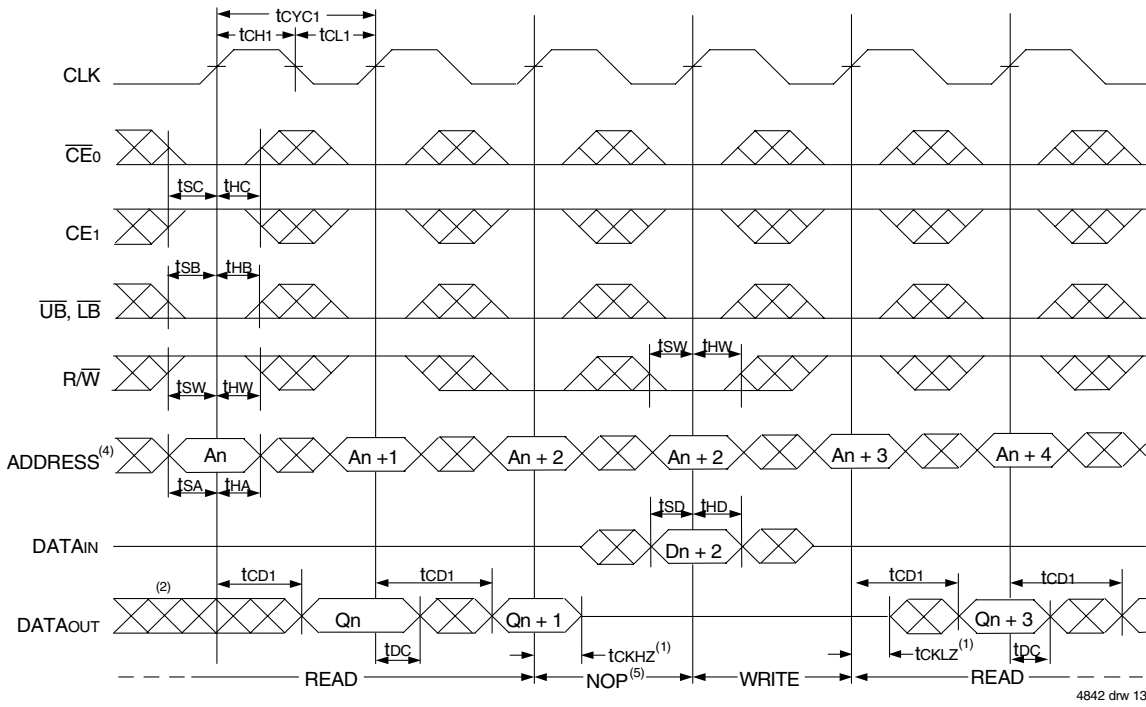

4842 drw 13

Timing Waveform of Flow-Through Read-to-Write-to-Read (\overline{OE} Controlled)⁽³⁾

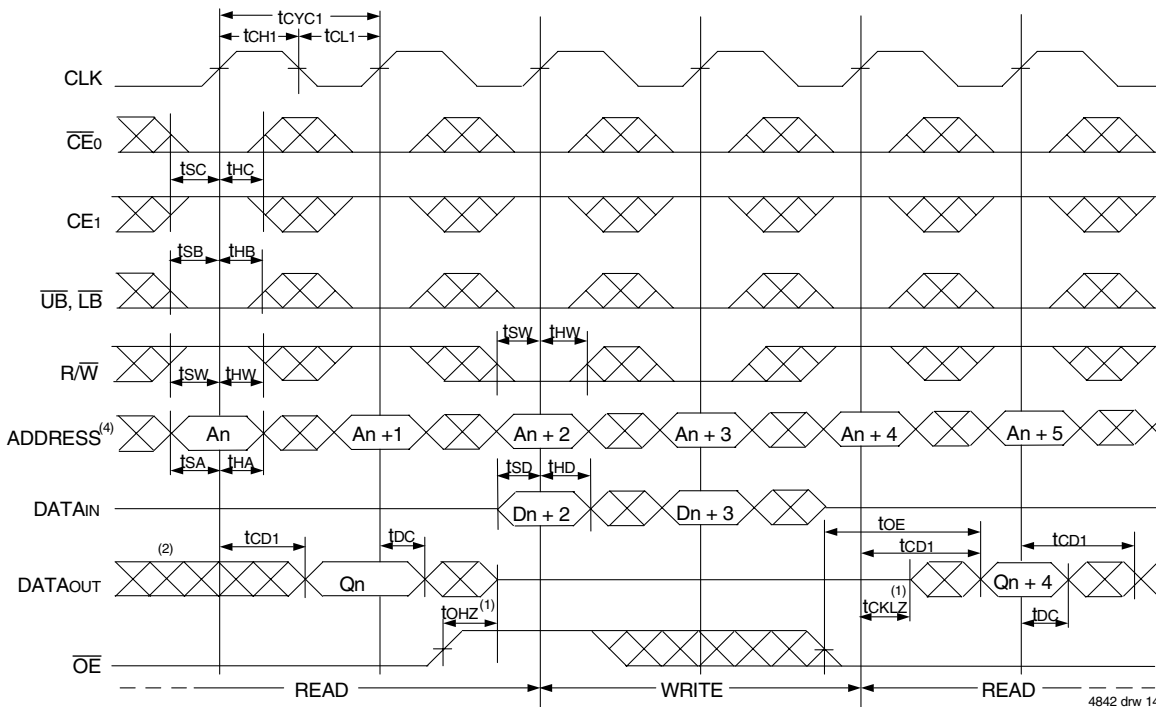

4842 drw 14

NOTES:

1. Transition is measured 0mV from Low or High-impedance voltage with the Output Test Load (Figure 2).
2. Output state (High, Low, or High-impedance) is determined by the previous cycle control signals.
3. \overline{CE}_0 , \overline{UB} , \overline{LB} , and $\overline{ADS} = V_{IL}$; \overline{CE}_1 , \overline{CNTEN} , and $\overline{CNTRST} = V_{IH}$. "NOP" is "No Operation".
4. Addresses do not have to be accessed sequentially since $\overline{ADS} = V_{IL}$ constantly loads the address on the rising edge of the CLK; numbers are for reference use only.
5. "NOP" is "No Operation." Data in memory at the selected address may be corrupted and should be re-written to guarantee data integrity.

Timing Waveform of Pipelined Read with Address Counter Advance⁽¹⁾

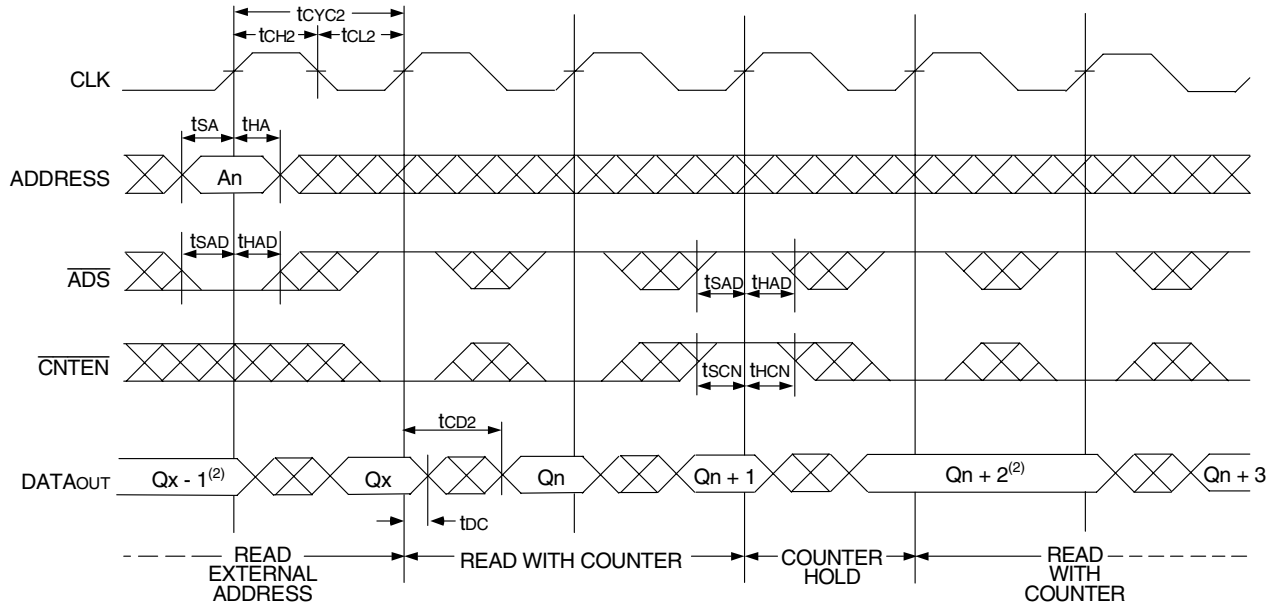

4842 drw 15

Timing Waveform of Flow-Through Read with Address Counter Advance⁽¹⁾

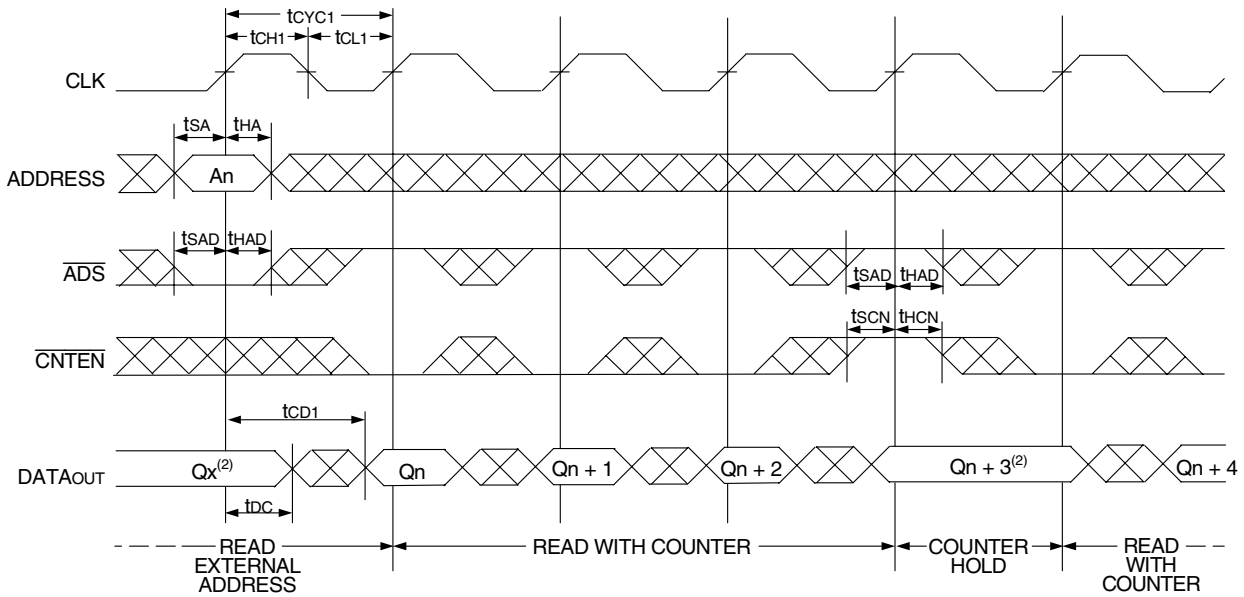

4842 drw 16

NOTES:

1. \overline{CE}_0 , \overline{OE} , \overline{UB} , and $\overline{LB} = V_{IL}$; CE_1 , $R\overline{W}$, and $\overline{CNTRST} = V_{IH}$.
2. If there is no address change via $\overline{ADS} = V_{IL}$ (loading a new address) or $\overline{CNTEN} = V_{IL}$ (advancing the address), i.e. $\overline{ADS} = V_{IH}$ and $\overline{CNTEN} = V_{IH}$, then the data output remains constant for subsequent clocks.

Timing Waveform of Write with Address Counter Advance (Flow-Through or Pipelined Outputs)⁽¹⁾

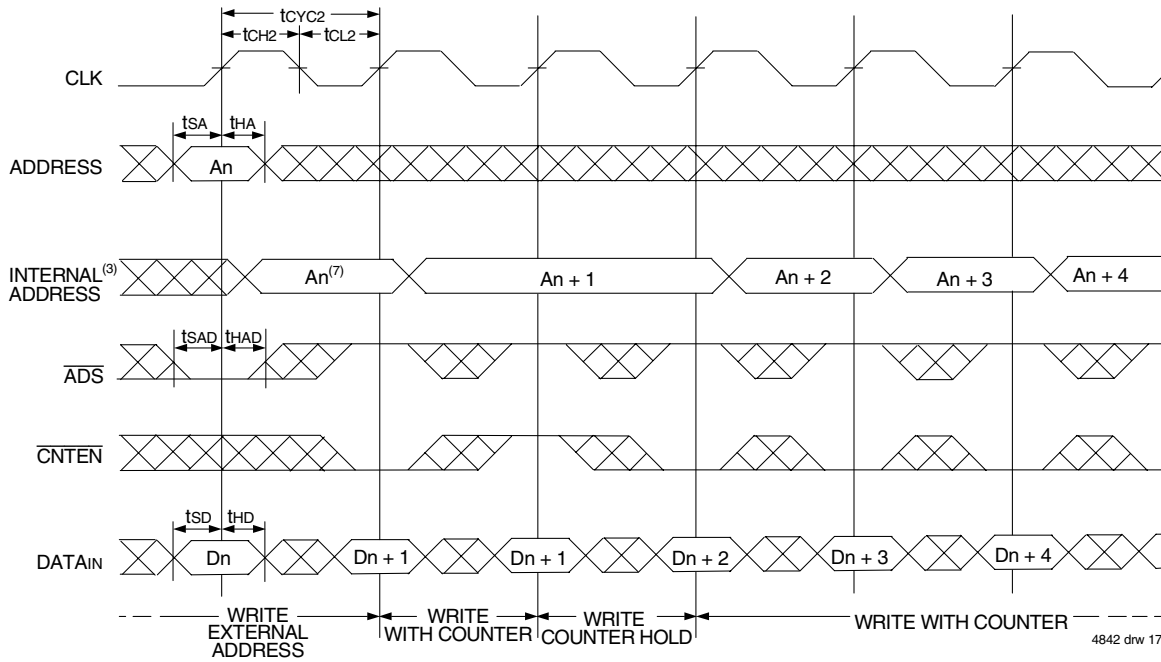

Timing Waveform of Counter Reset (Pipelined Outputs)⁽²⁾

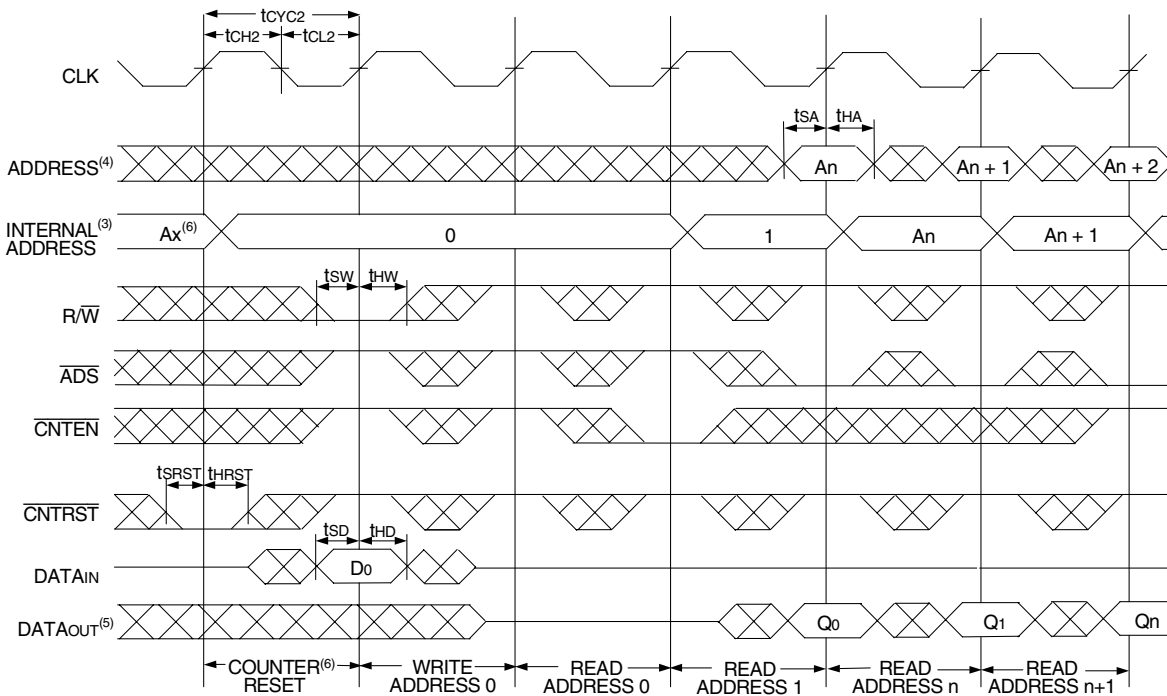

NOTES:

1. $\overline{CE}_0, \overline{UB}, \overline{LB}$, and $R/\overline{W} = V_{IL}$; CE_1 and $\overline{CNTRST} = V_{IH}$.
2. $\overline{CE}_0, \overline{UB}, \overline{LB} = V_{IL}$; $CE_1 = V_{IH}$.
3. The "Internal Address" is equal to the "External Address" when $\overline{ADS} = V_{IL}$ and equals the counter output when $\overline{ADS} = V_{IH}$.
4. Addresses do not have to be accessed sequentially since $\overline{ADS} = V_{IL}$ constantly loads the address on the rising edge of the CLK; numbers are for reference use only.
5. Output state (High, Low, or High-impedance) is determined by the previous cycle control signals.
6. No dead cycle exists during counter reset. A READ or WRITE cycle may be coincidental with the counter reset cycle.
7. $\overline{CNTEN} = V_{IL}$ advances Internal Address from 'An' to 'An + 1'. The transition shown indicates the time required for the counter to advance. The 'An + 1' Address is written to during this cycle.

A Functional Description

The IDT709289 provides a true synchronous Dual-Port Static RAM interface. Registered inputs provide minimal set-up and hold times on address, data, and all critical control inputs. All internal registers are clocked on the rising edge of the clock signal, however, the self-timed internal write pulse is independent of the LOW to HIGH transition of the clock signal.

An asynchronous output enable is provided to ease asynchronous bus interfacing. Counter enable inputs are also provided to stall the operation of the address counters for fast interleaved memory applications.

$\overline{CE}_0 = V_{IH}$ or $CE_1 = V_{IL}$ for one clock cycle will power down the internal circuitry to reduce static power consumption. Multiple chip enables allow easier banking of multiple IDT709289's for depth expansion configurations. When the Pipelined output mode is enabled, two cycles are required with $\overline{CE}_0 = V_{IL}$ and $CE_1 = V_{IH}$ to reactivate the outputs.

Depth and Width Expansion

The IDT709289 features dual chip enables (refer to Truth Table I) in order to facilitate rapid and simple depth expansion with no requirements for external logic. Figure 4 illustrates how to control the various chip enables in order to expand two devices in depth.

The 709289 can also be used in applications requiring expanded width, as indicated in Figure 4. Since the banks are allocated at the discretion of the user, the external controller can be set up to drive the input signals for the various devices as required to allow for 32-bit or wider applications.

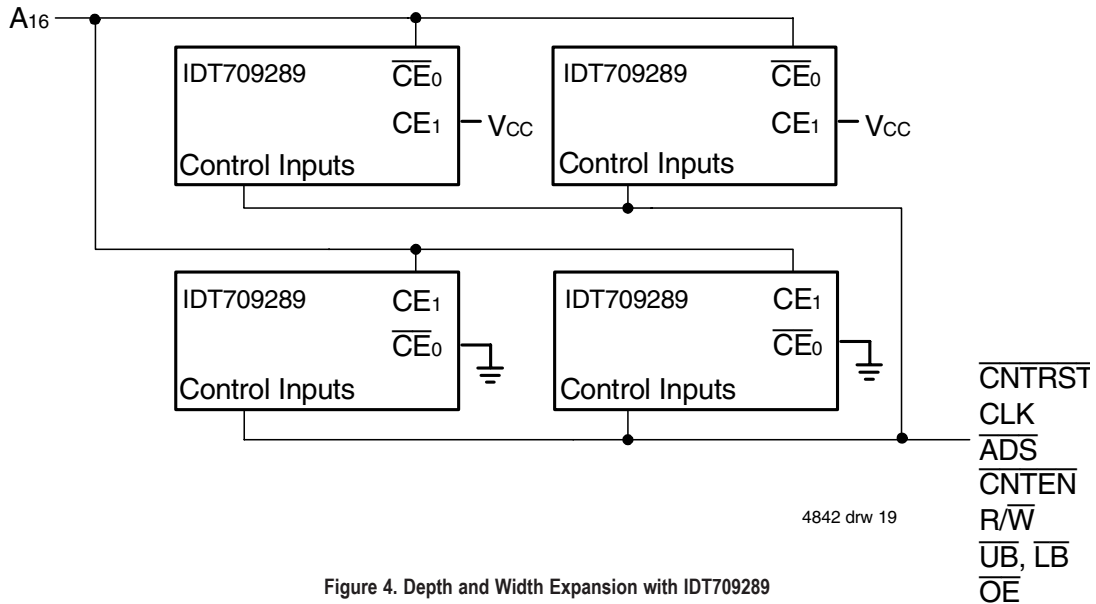

Figure 4. Depth and Width Expansion with IDT709289

Ordering Information

XXXXX	A	99	A	A	A	A	
Device Type	Power	Speed	Package		Process/ Temperature Range		
							Blank 8 Tube or Tray Tape & Reel
							Blank ⁽¹⁾ Commercial (0 C to +70 C) Industrial (-40 C to +85 C)
							G ⁽²⁾ Green
							PF 100-pin TQFP (PN100)
							7 Commercial Only 9 Commercial & Industrial 12 Commercial Only } Speed in nanoseconds
							L Low Power
							709289 1024K (64K x 16-Bit) Synchronous Dual-Port RAM

4842 drw 20

NOTES:

1. Industrial temperature range is available. For specific speeds, packages and powers contact your sales office.
2. Green parts available. For specific speeds, packages and powers contact your local sales office.

Datasheet Document History

9/30/99:	Initial Public Release
11/10/99:	Replaced IDT logo
12/22/99:	Page 1 Added missing diamond
1/5/01:	Page 4 Changed information in Truth Table II Increased storage temperature parameter Clarified TA parameter
	Page 5 DC Electrical parameters—changed wording from "open" to "disabled" Changed ±200mV to 0mV in notes
	Removed Preliminary specification
10/18/01:	Page 2 Added date revision for pin configuration
	Page 5 & 7 Added Industrial temp to column heading and values for 9ns speed to DC & AC Electrical Characteristics
	Page 15 Added Industrial temp offering to 9ns ordering information
	Page 4, 5 & 7 Removed Industrial temp footnote from all tables
	Page 1 & 15 Replace ™ logo with ® logo

Datasheet Document History (con't on next page)

Datasheet Document History

05/05/06: Page 1 Added green availability to features
Page 15 Added green indicator to ordering information

01/19/09: Page 15 Removed "IDT" from orderable part number

02/27/15: Page 2 Removed IDTin reference to fabrication
Page 2 Removed date from PN100 pin configuration
Page 2&15 The package code PN100-1 changed to PN100 to match standard package codes,
Page 6 Removed typo from typical output derating drawing
Page 15 Added Tape & Reel to the Ordering Information

**CORPORATE HEADQUARTERS**

6024 Silver Creek Valley Road
San Jose, CA 95138

for SALES:

800-345-7015 or 408-284-8200
fax: 408-284-2775
www.idt.com

for Tech Support:

408-284-2794
DualPortHelp@idt.com

The IDT logo is a registered trademark of Integrated Device Technology, Inc.