

## MAX5048C

## 7A Sink/3A Source Current, 8ns, SOT23, MOSFET Driver

### General Description

The MAX5048C is a high-speed MOSFET driver capable of sinking/sourcing 7A/3A peak currents. This device takes logic input signals and drives a large external MOSFET. The device has inverting and noninverting inputs that give the user greater flexibility in controlling the MOSFET. The device also has the features necessary to drive low-side enhancement-mode Gallium Nitride (GaN) FETs. The device features two separate outputs working in complementary mode, offering flexibility in controlling both turn-on and turn-off switching speeds.

The device has internal logic circuitry, which prevents shoot-through during output state changes. The logic inputs are protected against voltage spikes up to +14V, regardless of V+ voltage. Propagation delay time is minimized and matched between the inverting and noninverting inputs. The device has very fast switching times combined with very short propagation delays (8ns, typ) making it ideal for high-frequency circuits.

The device operates from a +4V to +14V single power supply, typically consuming 0.5mA of supply current and has TTL input logic levels. This device is available in a 6-pin SOT23 package and provides an upgrade path for users of the MAX5048B.

### Applications

- Power MOSFET Switching
- Switch-Mode Power Supplies
- DC-DC Converters
- Motor Control
- Power-Supply Modules

[Ordering Information](#) appears at end of data sheet.

### Benefits and Features

- Improved Power Conversion Efficiency
  - Low 8ns Propagation Delay
  - 5ns Typical Rise and 4ns Typical Fall Times with 1nF Load
  - 0.3Ω Open-Drain n-Channel Sink Output
  - 0.84Ω Open-Drain p-Channel Source Output
- Improved EMI
  - Independent Source/Sink Outputs for Controllable Rise and Fall Times
- Reduced Solution Size and Cost
  - Low Input Capacitance (10pF, typ)
  - 6-Pin SOT-23 Package
  - +4V to +14V Single Power Supply
- Greater Flexibility in Controlling the MOSFET
  - Matching Delay Time Between Inverting and Noninverting Inputs
  - 7A/3A Peak Sink/Source Drive Current
  - TTL Logic-Level Inputs with Hysteresis for Noise Immunity
- Improved System Reliability
  - Inputs Rated to +14V Regardless of V+ Voltage
  - Thermal Shutdown Protection
  - -40°C to +125°C Operating Temperature Range
- Easy Upgrade from MAX5048B
  - Pin-Compatible with the MAX5048B

### Typical Operating Circuit

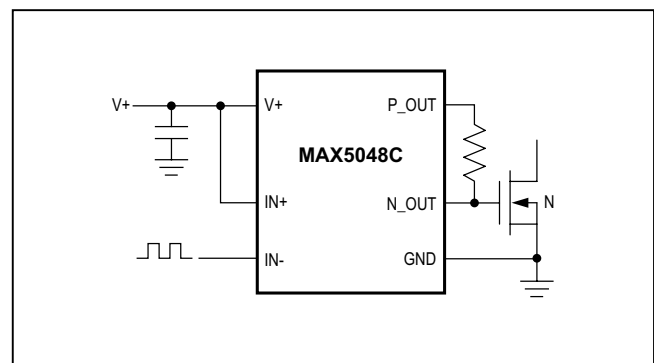

### Absolute Maximum Ratings

|   |                 |   |        |
|---|-----------------|---|--------|
| V+, IN+, IN-, P_OUT, N_OUT to GND ..... | -0.3V to +16V   | Junction Temperature .....              | +150°C |
| Operating Temperature Range .....       | -40°C to +125°C | Lead Temperature (soldering, 10s) ..... | +300°C |
| Storage Temperature Range .....         | -65°C to +150°C |   |        |

Stresses beyond those listed under "Absolute Maximum Ratings" may cause permanent damage to the device. These are stress ratings only, and functional operation of the device at these or any other conditions beyond those indicated in the operational sections of the specifications is not implied. Exposure to absolute maximum rating conditions for extended periods may affect device reliability.

### Package Thermal Characteristics (Note 1)

Junction-to-Ambient Thermal Resistance ( $\theta_{JA}$ ) .....80°C/W

**Note 1:** Measured on the MAX5048C evaluation kit.

### Electrical Characteristics

(V+ = 12V, C<sub>L</sub> = 0, T<sub>A</sub> = -40°C to +125°C, unless otherwise noted. Typical values are specified at T<sub>A</sub> = +25°C.) (Note 2)

| PARAMETER                             | SYMBOL            | CONDITIONS   | MIN   | TYP  | MAX   | UNITS |
|---------------------------------------|-------------------|--|-------|------|-------|-------|
| <b>POWER SUPPLY (V+)</b>              |                   |  |       |      |       |       |
| V+ Operating Range                    | V+                |  | 4     |      | 14    | V     |
| V+ Undervoltage Lockout               | UVLO              | V+ rising  | 3.28  | 3.45 | 3.63  | V     |
| V+ UVLO Hysteresis                    |                   |  |       | 200  |       | mV    |
| V+ UVLO to Output Delay               |                   | V+ rising, IN+ = V+, IN- = GND                                       |       | 127  |       | µs    |
| V+ Supply Current                     | I+Q               | Not switching, V+ = 14V  |       | 0.5  | 1     | mA    |
|                                       | I+SW              | V+ = 6 V, switching at 1MHz  |       | 2.65 |       |       |
| <b>n-CHANNEL OUTPUT</b>               |                   |  |       |      |       |       |
| Driver Output Resistance Pulling Down | R <sub>ON-N</sub> | V+ = 14V, I <sub>N_OUT</sub> = -100mA                                |       | 0.31 | 0.55  | Ω     |
|                                       |                   | V+ = 4.5V, I <sub>N_OUT</sub> = -100mA                               |       | 0.32 | 0.56  |       |
| Power-Off Pulldown Resistance         |                   | V+ = unconnected, I <sub>N_OUT</sub> = -10mA, T <sub>A</sub> = +25°C | 4     | 6.1  | 8.5   | Ω     |
| Power-Off Pulldown Clamp Voltage      |                   | V+ = unconnected, I <sub>N_OUT</sub> = -10mA, T <sub>A</sub> = +25°C | 0.95  | 1.29 | 1.65  | V     |
| Output Leakage Current                | I <sub>LK-N</sub> | N_OUT = 14V  |       | 6.5  | 11    | µA    |
| Peak Output Current (Sinking)         | I <sub>PK-N</sub> | C <sub>L</sub> = 10 nF   |       | 7    |       | A     |
| <b>p-CHANNEL OUTPUT</b>               |                   |  |       |      |       |       |
| Driver Output Resistance Pulling Up   | R <sub>ON-P</sub> | V+ = 14V, I <sub>P_OUT</sub> = 100mA                                 |       | 0.84 | 1.47  | Ω     |
|                                       |                   | V+ = 4.5V, I <sub>P_OUT</sub> = 100mA                                |       | 0.88 | 1.55  |       |
| Output Leakage Current                | I <sub>LK-P</sub> | P_OUT = 0V   | -1    |      | +1    | µA    |
| Peak Output Current (Sourcing)        | I <sub>PK-P</sub> | C <sub>L</sub> = 10nF  |       | 3    |       | A     |
| <b>LOGIC INPUT (IN+, IN-)</b>         |                   |  |       |      |       |       |
| Logic High Input Voltage              | V <sub>IH</sub>   |  | 2.0   |      |       | V     |
| Logic Low Input Voltage               | V <sub>IL</sub>   |  |       |      | 0.8   | V     |
| Logic Input Hysteresis                | V <sub>HYS</sub>  |  |       | 300  |       | mV    |
| Logic Input Current                   |                   | IN+ = IN- = V+ or 0V, V+ = 14V                                       | -1000 |      | +1000 | nA    |
| Logic Input Capacitance               | C <sub>IN</sub>   | (Note 3)   |       | 10   |       | pF    |

**Electrical Characteristics (continued)**(V+ = 12V, C<sub>L</sub> = 0, T<sub>A</sub> = -40°C to +125°C, unless otherwise noted. Typical values are specified at T<sub>A</sub> = +25°C.) (Note 2)

| <b>SWITCHING CHARACTERISTICS (V+ = 14V) (Figure 2 and Note 3)</b>  |                    |                        |     |   |    |    |
|--|--------------------|------------------------|-----|---|----|----|
| Rise Time  | t <sub>R</sub>     | C <sub>L</sub> = 1nF   | 5   |   |    | ns |
|  |                    | C <sub>L</sub> = 4.7nF | 19  |   |    |    |
|  |                    | C <sub>L</sub> = 10nF  | 37  |   |    |    |
| Fall Time  | t <sub>F</sub>     | C <sub>L</sub> = 1nF   | 4   |   |    | ns |
|  |                    | C <sub>L</sub> = 4.7nF | 10  |   |    |    |
|  |                    | C <sub>L</sub> = 10nF  | 18  |   |    |    |
| Turn-On Delay Time   | t <sub>D-ON</sub>  | C <sub>L</sub> = 1nF   | 3   | 7 | 18 | ns |
| Turn-Off Delay Time  | t <sub>D-OFF</sub> | C <sub>L</sub> = 1nF   | 3   | 7 | 18 | ns |
| Break-Before-Make Time   |                    |                        | 5   |   |    | ns |
| <b>SWITCHING CHARACTERISTICS (V+ = 4.5V) (Figure 2 and Note 3)</b> |                    |                        |     |   |    |    |
| Rise Time  | t <sub>R</sub>     | C <sub>L</sub> = 1nF   | 4   |   |    | ns |
|  |                    | C <sub>L</sub> = 4.7nF | 13  |   |    |    |
|  |                    | C <sub>L</sub> = 10nF  | 28  |   |    |    |
| Fall Time  | t <sub>F</sub>     | C <sub>L</sub> = 1nF   | 4   |   |    | ns |
|  |                    | C <sub>L</sub> = 4.7nF | 7   |   |    |    |
|  |                    | C <sub>L</sub> = 10nF  | 13  |   |    |    |
| Turn-On Delay Time   | t <sub>D-ON</sub>  | C <sub>L</sub> = 1nF   | 2   | 8 | 21 | ns |
| Turn-Off Delay Time  | t <sub>D-OFF</sub> | C <sub>L</sub> = 1nF   | 2   | 8 | 21 | ns |
| Break-Before-Make Time   |                    |                        | 5   |   |    | ns |
| <b>THERMAL SHUTDOWN</b>  |                    |                        |     |   |    |    |
| Thermal Shutdown Threshold   |                    | Temperature rising     | 166 |   |    | °C |
| Thermal Shutdown Hysteresis  |                    |                        | 13  |   |    | °C |

**Note 2:** All devices are production tested at T<sub>A</sub> = +25°C. Limits over temperature are guaranteed by design.**Note 3:** Design guaranteed by bench characterization. Limits are not production tested.

Typical Operating Characteristics

( $C_L = 1nF$ ,  $T_A = +25^\circ C$ , unless otherwise noted.)

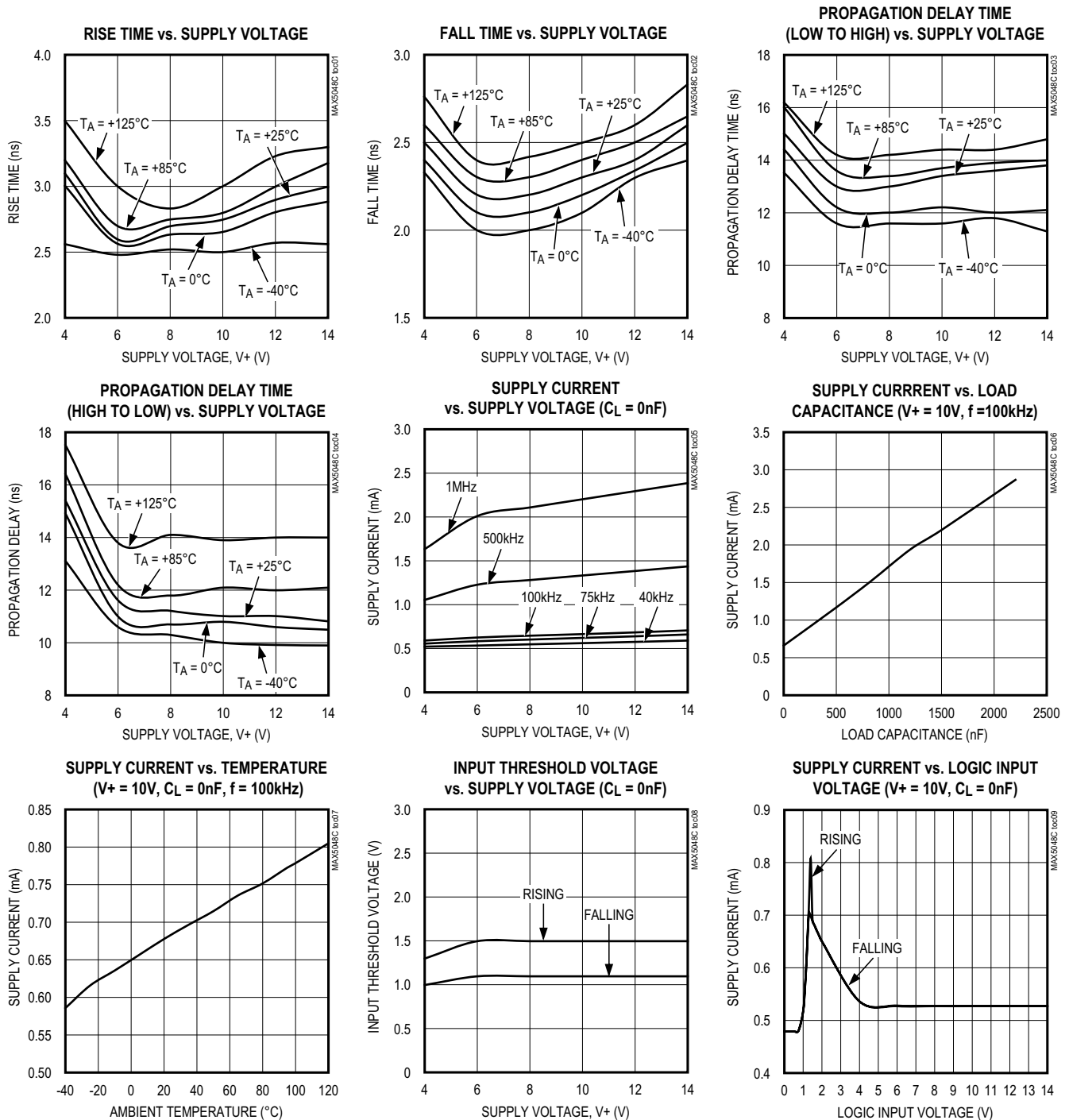

Typical Operating Characteristics (continued)

( $C_L = 1\text{nF}$ ,  $T_A = +25^\circ\text{C}$ , unless otherwise noted.)

LOGIC INPUT VOLTAGE vs. OUTPUT  
VOLTAGE ( $V_+ = +4\text{V}$ ,  $C_L = 4.7\text{nF}$ )

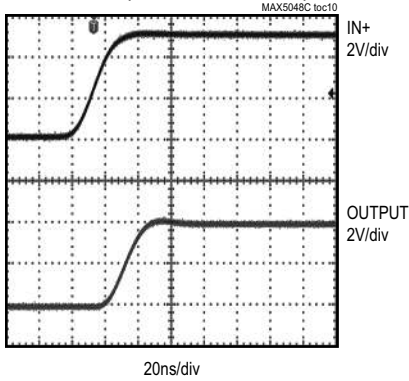

LOGIC INPUT VOLTAGE vs. OUTPUT  
VOLTAGE ( $V_+ = +4\text{V}$ ,  $C_L = 10\text{nF}$ )

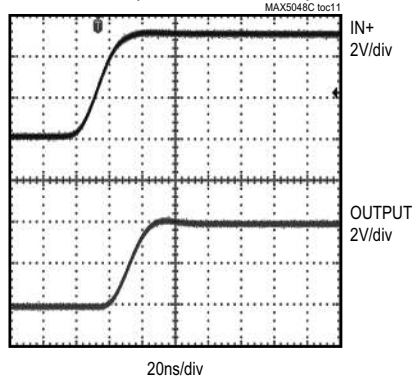

LOGIC INPUT VOLTAGE vs. OUTPUT  
VOLTAGE ( $V_+ = +4\text{V}$ ,  $C_L = 4.7\text{nF}$ )

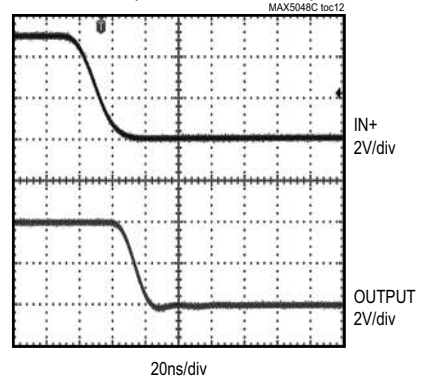

LOGIC INPUT VOLTAGE vs. OUTPUT  
VOLTAGE ( $V_+ = +4\text{V}$ ,  $C_L = 10\text{nF}$ )

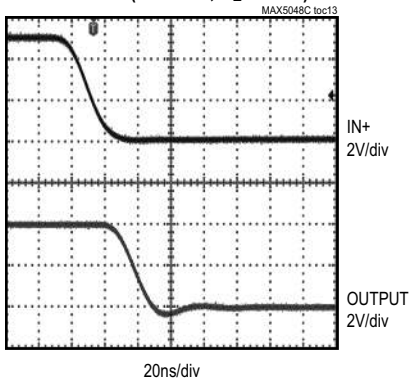

LOGIC INPUT VOLTAGE vs. OUTPUT  
VOLTAGE ( $V_+ = +14\text{V}$ ,  $C_L = 4.7\text{nF}$ )

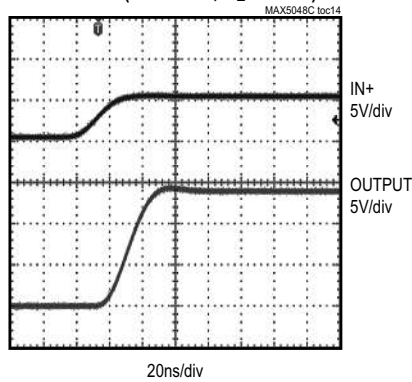

LOGIC INPUT VOLTAGE vs. OUTPUT  
VOLTAGE ( $V_+ = +14\text{V}$ ,  $C_L = 10\text{nF}$ )

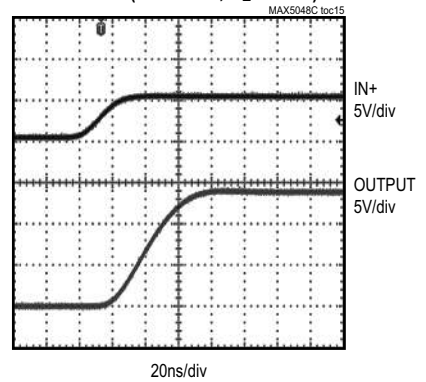

LOGIC INPUT VOLTAGE vs. OUTPUT  
VOLTAGE ( $V_+ = +14\text{V}$ ,  $C_L = 4.7\text{nF}$ )

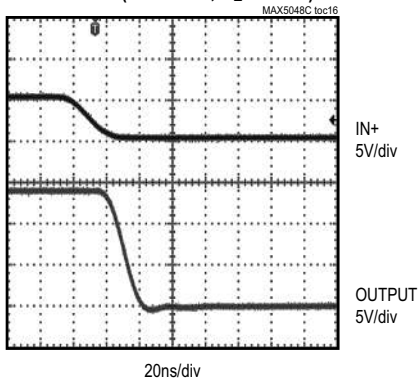

LOGIC INPUT VOLTAGE vs. OUTPUT  
VOLTAGE ( $V_+ = +14\text{V}$ ,  $C_L = 10\text{nF}$ )

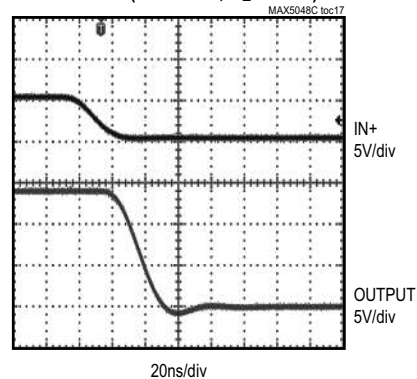

Pin Configuration

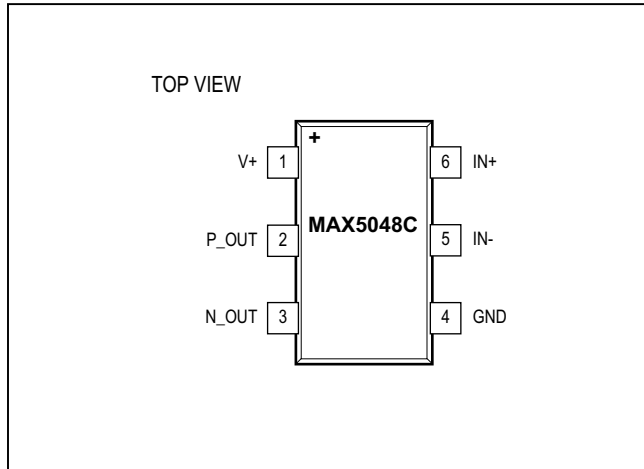

Pin Description

| PIN | NAME  | FUNCTION   |
|-----|-------|--|
| 1   | V+    | Power-Supply Input. Bypass to GND with a minimum of 1μF low-ESR ceramic capacitor. |
| 2   | P_OUT | Open-Drain p-Channel Output. Sources current for MOSFET turn-on.                   |
| 3   | N_OUT | Open-Drain n-Channel Output. Sinks current for MOSFET turn-off.                    |
| 4   | GND   | Ground   |
| 5   | IN-   | Inverting Logic Input Terminal. Connect to GND when not used.                      |
| 6   | IN+   | Noninverting Logic Input Terminal. Connect to V+ when not used.                    |

Functional Diagram

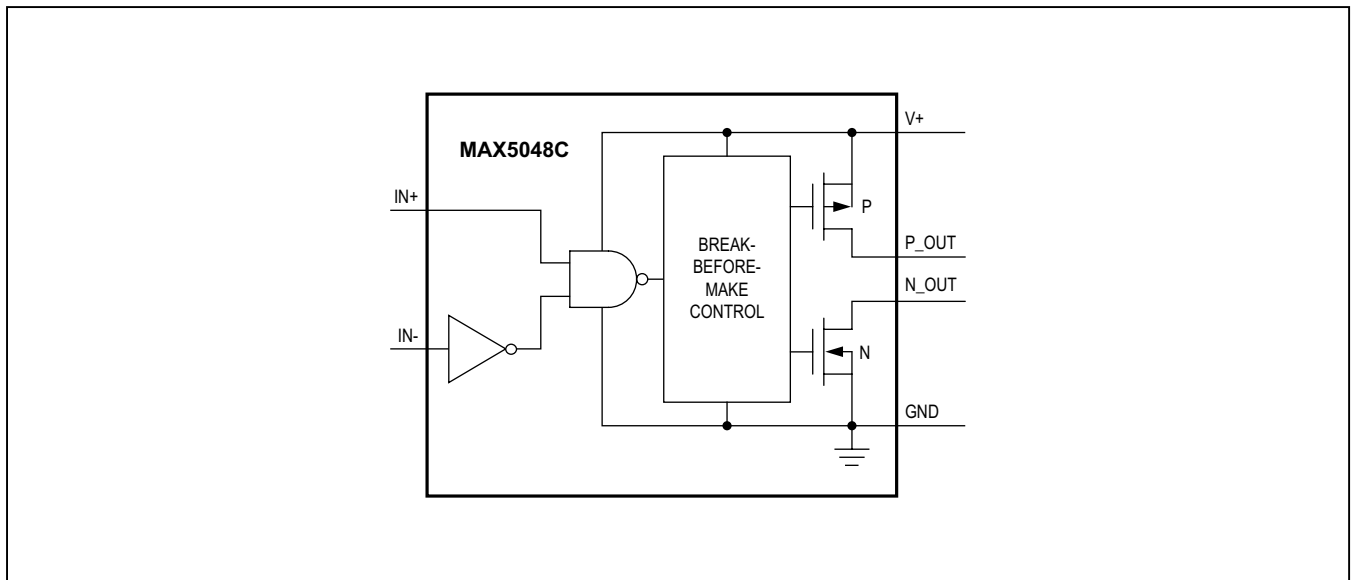

Figure 1. MAX5048C Functional Block Diagram

Timing Diagram and Test Circuit

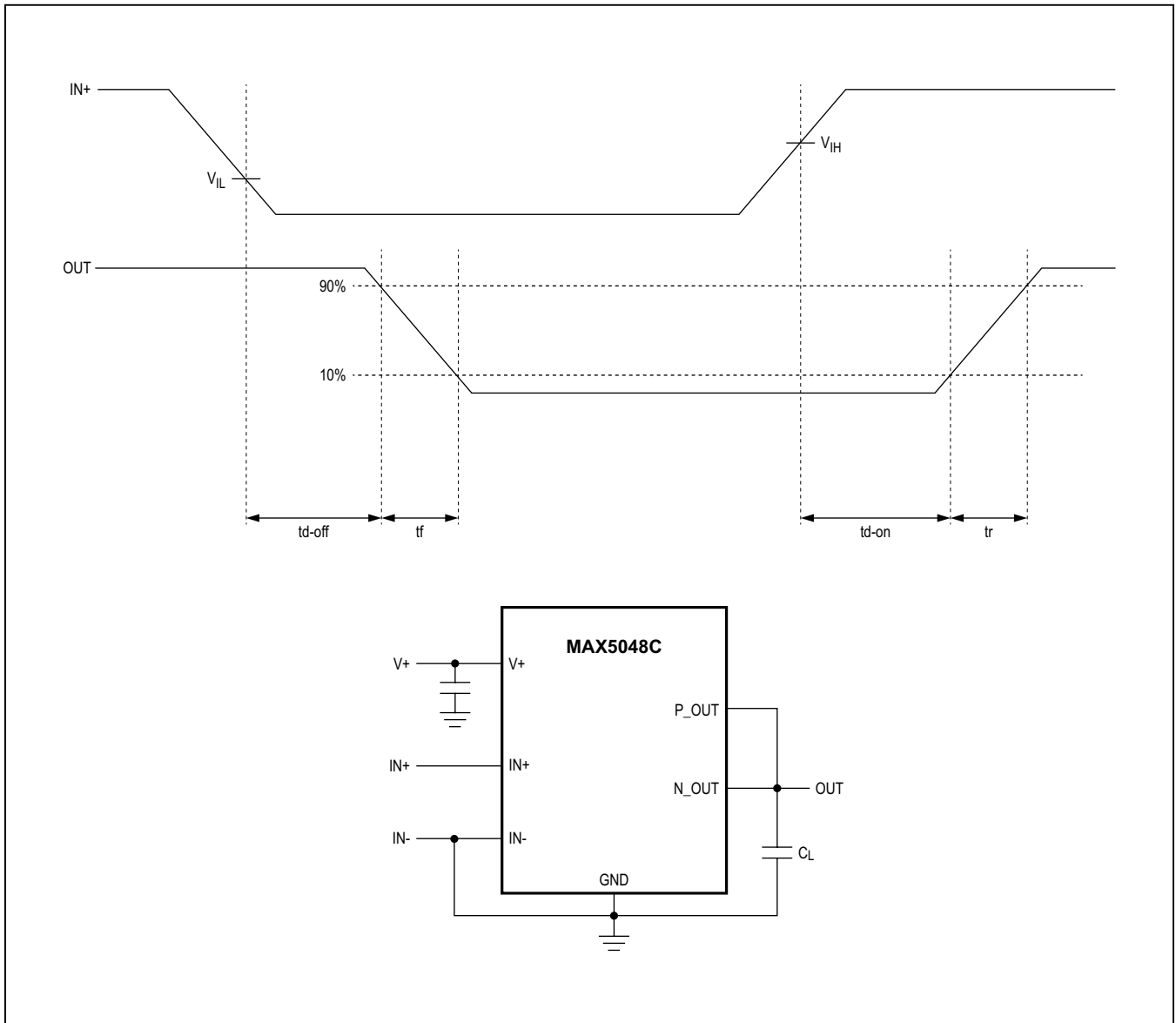

Figure 2. Timing Diagram and Test Circuit for IN+ Operation

**Table 1. Truth Table**

| IN+ | IN- | P_OUT | N_OUT |
|-----|-----|-------|-------|
| L   | L   | Off   | On    |
| L   | H   | Off   | On    |
| H   | L   | On    | Off   |
| H   | H   | Off   | On    |

L = Logic-low.  
H = Logic-high.

## Detailed Description

### Logic Inputs

The MAX5048C has a TTL inverting and noninverting input that gives the user greater flexibility in controlling the MOSFET. Table 1 shows all the possible input combinations and the corresponding output states.

### Undervoltage Lockout (UVLO)

When V+ is below the UVLO threshold, the output-stage n-channel device is on and the p-channel is off, independent of the state of the inputs. This holds the outputs low. The UVLO is typically 3.45V with 200mV typical hysteresis to avoid chattering.

### Driver Outputs

The device provides two separate outputs. One is an open-drain p-channel, the other an open-drain n-channel. They have distinct current sourcing/sinking capabilities to independently control the rise and fall times of the MOSFET gate. Add a resistor in series with P\_OUT/N\_OUT to slow the corresponding rise/fall time of the MOSFET gate.

## Applications Information

### Supply Bypassing, Device Grounding, and Placement

Ample supply bypassing and device grounding are extremely important because when large external capacitive loads are driven, the peak current at the V+ pin can approach 3A, while at the GND pin the peak current can approach 7A. V+ drops and ground shifts are forms of negative feedback for inverters and, if excessive, can cause multiple switching when the inverting input is used and the input slew rate is low. The device driving the input should be referenced to the GND pin, especially when the inverting input is used. Ground shifts due to insufficient device grounding may disturb other circuits sharing the same AC ground return path. Any series inductance in

the V+, P\_OUT, N\_OUT, and/or GND paths can cause oscillations due to the very high di/dt that results when the device is switched with any capacitive load. A minimum of 1μF, low-ESR ceramic capacitor is recommended, bypassing V+ to GND and placed as close as possible to the pins. When driving very large loads (e.g., 10nF) at minimum rise time, 10μF or more of parallel storage capacitance is recommended. A ground plane is highly recommended to minimize ground return resistance and series inductance. Care should be taken to place the device as close as possible to the external MOSFET being driven to further minimize board inductance and AC path resistance.

### Power Dissipation

Power dissipation of the device consists of three components, caused by the quiescent current, capacitive charge and discharge of internal nodes, and the output current (either capacitive or resistive load). The sum of these components must be kept below the maximum power-dissipation limit corresponding value.

The quiescent current is 0.5mA (typ). The current required to charge and discharge the internal nodes is frequency dependent (see the *Typical Operating Characteristics*). The device's approximate power dissipation when driving a ground-referenced resistive load is:

$$P = D \times R_{ON} (MAX) \times I_{LOAD}^2$$

where D is the fraction of the period that the device output pulls high,  $R_{ON} (MAX)$  is the maximum pullup on-resistance of the device with the output high, and  $I_{LOAD}$  is the output load current of the device.

For capacitive loads, the approximate power dissipation is:

$$P = C_{LOAD} \times (V+)^2 \times \text{FREQ}$$

where  $C_{LOAD}$  is the capacitive load, V+ is the supply voltage, and FREQ is the switching frequency.

### PCB Layout Information

The MOSFET driver can source and sink large currents to create very fast rise and fall edges at the gate of the switching MOSFET. The high di/dt can cause unacceptable ringing if the trace lengths and impedances are not well controlled. The following PCB layout guidelines are recommended when designing with the MAX5048C:

- Place at least 1μF decoupling ceramic capacitor from V+ to GND as close as possible to the device. At least one storage capacitor of 10μF (min) should be located on the PCB with a low resistance path to the V+ pin of the device.



# MAX5048C

# 7A Sink/3A Source Current, 8ns, SOT23, MOSFET Driver

- There are two AC current loops formed between the device and the gate of the MOSFET being driven. The MOSFET looks like a large capacitance from gate to source when the gate is being pulled low. The active current loop is from N\_OUT of the device to the MOSFET gate, to the MOSFET source, and to GND of the device.
- When the gate of the MOSFET is being pulled high, the active current loop is from P\_OUT of the device, to the MOSFET gate, to the MOSFET source, to the

GND terminal of the decoupling capacitor, to the V+ terminal of the decoupling capacitor, and to the V+ terminal of the device. While the charging current loop is important, the discharging current loop is also critical. It is important to minimize the physical distance and the impedance in these AC current loops.

- In a multilayer PCB, the component surface layer surrounding the device should consist of a GND plane containing the discharging and charging current loops.

## Typical Application Circuits

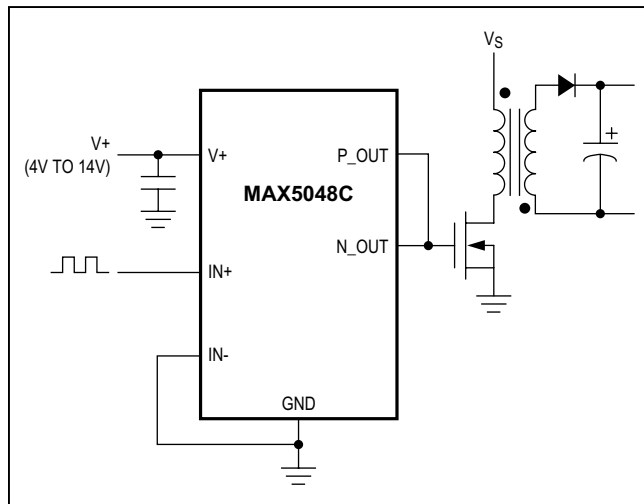

Figure 3. Noninverting Application

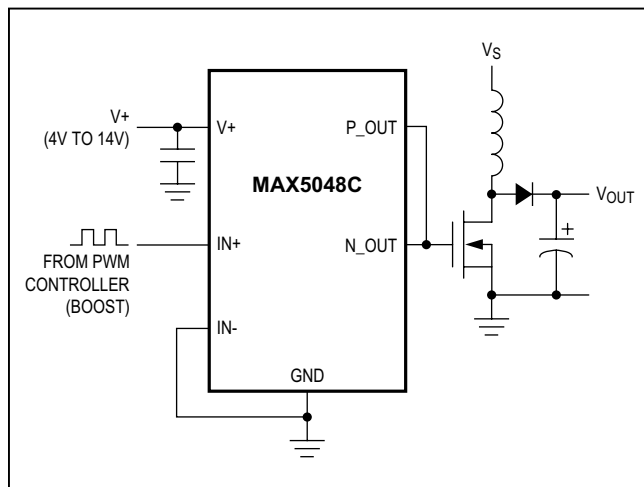

Figure 4. Boost Converter

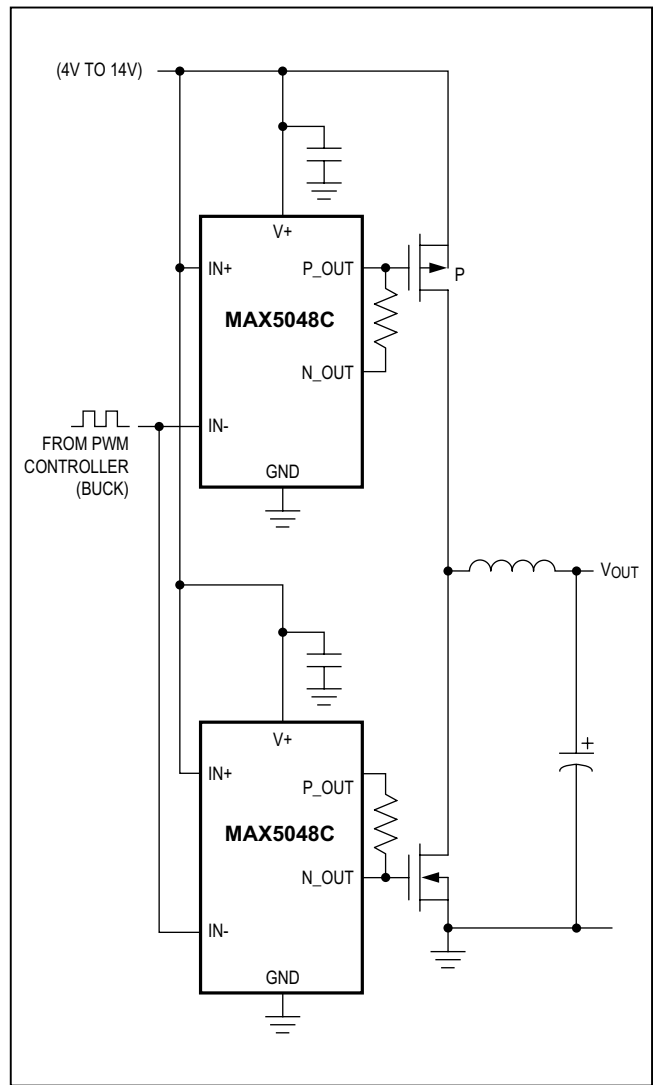

Figure 5. MAX5048C in High-Power Synchronous Buck Converter

MAX5048C

7A Sink/3A Source Current, 8ns,  
SOT23, MOSFET Driver

### Ordering Information

| PART         | TEMP RANGE      | PIN-PACKAGE | LOGIC INPUT | TOP MARK |
|--------------|-----------------|-------------|-------------|----------|
| MAX5048CAUT+ | -40°C to +125°C | 6 SOT23     | TTL         | +ACSC    |

+Denotes a lead(Pb)-free/RoHS-compliant package.

### Chip Information

PROCESS: BiCMOS

### Package Information

For the latest package outline information and land patterns (footprints), go to [www.maximintegrated.com/packages](http://www.maximintegrated.com/packages). Note that a "+", "#", or "-" in the package code indicates RoHS status only. Package drawings may show a different suffix character, but the drawing pertains to the package regardless of RoHS status.

| PACKAGE TYPE | PACKAGE CODE | OUTLINE NO.             | LAND PATTERN NO.        |
|--------------|--------------|-------------------------|-------------------------|
| 6 SOT23      | U6+8         | <a href="#">21-0058</a> | <a href="#">90-0175</a> |

## Revision History

| REVISION NUMBER | REVISION DATE | DESCRIPTION                                  | PAGES CHANGED |
|-----------------|---------------|--|---------------|
| 0               | 11/12         | Initial release                              | —             |
| 1               | 1/15          | Updated <i>Benefits and Features</i> section | 1             |

For pricing, delivery, and ordering information, please contact Maxim Direct at 1-888-629-4642, or visit Maxim Integrated's website at [www.maximintegrated.com](http://www.maximintegrated.com).

*Maxim Integrated cannot assume responsibility for use of any circuitry other than circuitry entirely embodied in a Maxim Integrated product. No circuit patent licenses are implied. Maxim Integrated reserves the right to change the circuitry and specifications without notice at any time. The parametric values (min and max limits) shown in the Electrical Characteristics table are guaranteed. Other parametric values quoted in this data sheet are provided for guidance.*