

10078991-GXX-XXULF

PLATING  
0.76µm GXT (Pd Ni WITH GOLD FLASH)  
OVER 1.27µm NICKEL UNDERPLATE

TAIL LENGTH

STYLE	TAIL LENGTH (mm)
2	2.5
3	3.1

LATCH TYPE:  
1-STANDARD : FOR USE WITH STRAIN-RELIEF 10073978  
2-LOW PROFILE : FOR USE WITHOUT STRAIN-RELIEF

SIZE: TOTAL NB OF POSITIONS  
SEE SHEET 2

PACKAGING. SEE NOTE 4

SUFFIX LETTER "LF" INDICATES  
THE PRODUCT IS ROHS  
COMPLIANT. SEE NOTE 5.

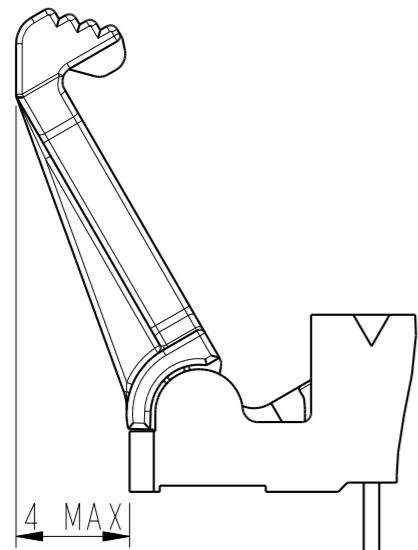

OPENED POSITION

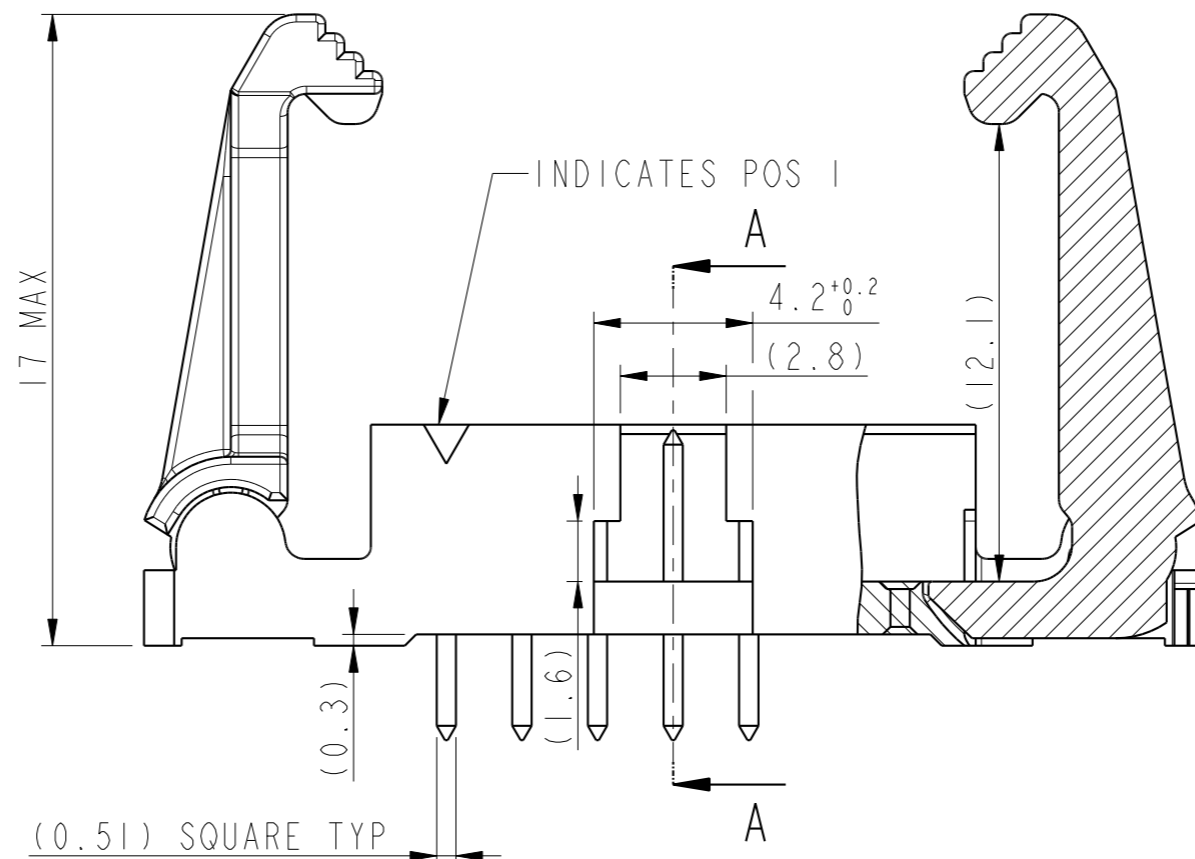
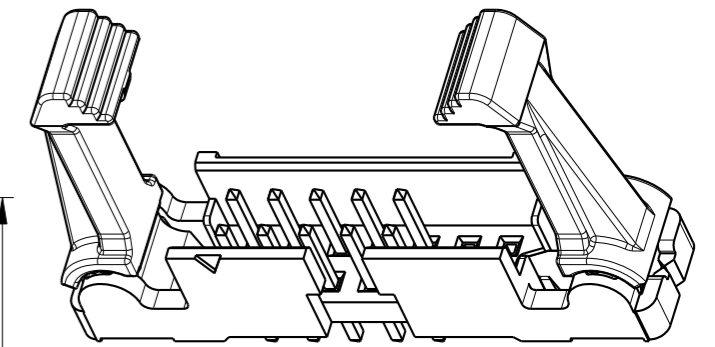
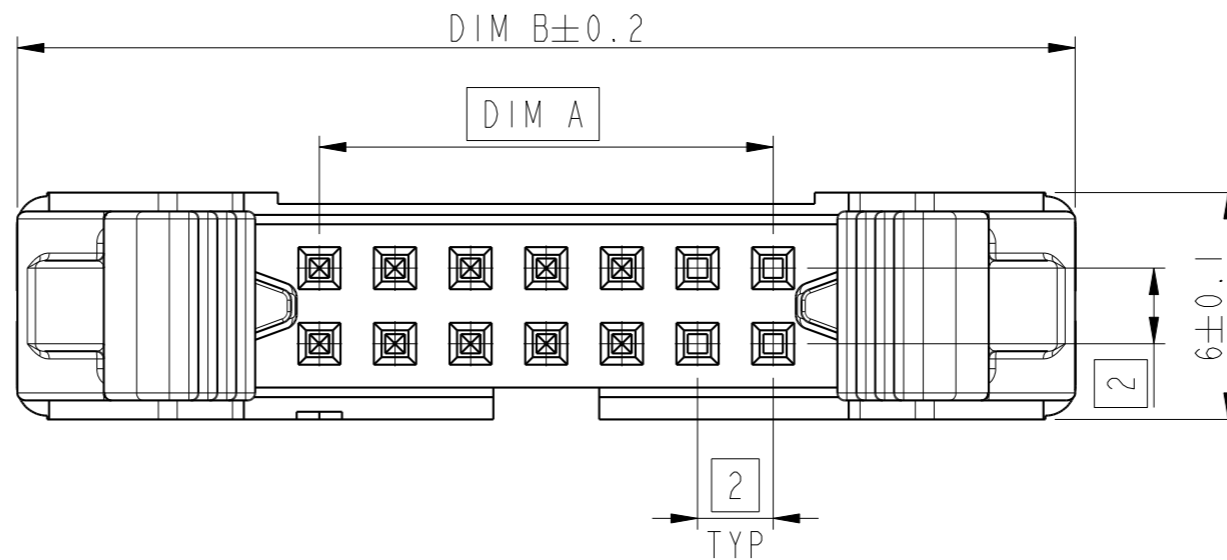

SECTION C-C  
VIEW WITH STANDARD LATCH

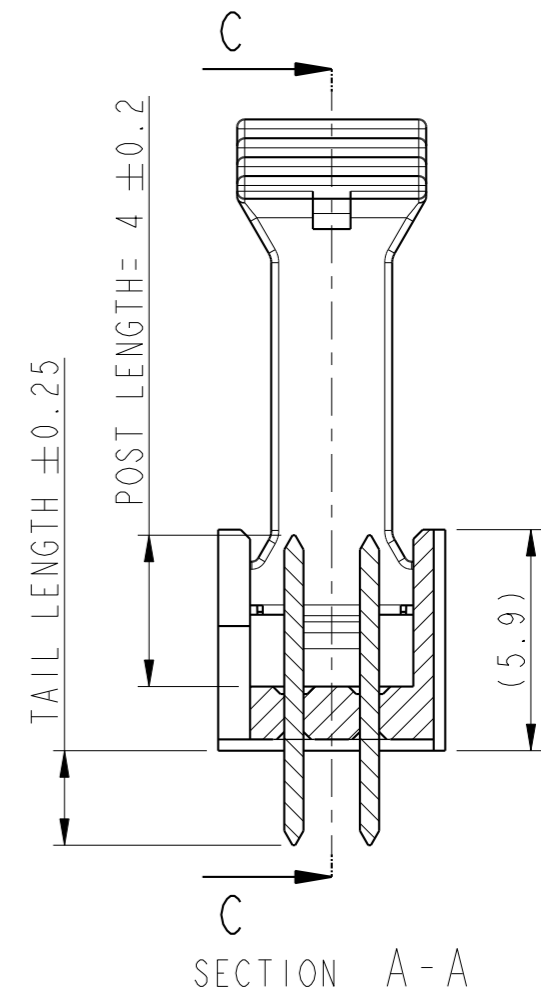

SECTION A-A

- NOTES :
- MATERIAL HOUSING: HIGH TEMPERATURE THERMOPLASTIC  
UL 94 VO . COLOR CREAM.
  - MATERIAL LATCH : HIGH TEMPERATURE THERMOPLASTIC  
UL 94 VO . COLOR BLACK.
  - MATERIAL TERMINAL : COPPER ALLOY
  - PIN RETENTION IN EITHER DIRECTION : 7N MIN
  - PACKAGING  
U= TUBE WITHOUT PICK UP CAP.
  - ROHS COMPATIBLE PRODUCT SPECIFICATIONS :
    - PLATING :  
"LF" MEANS THE PRODUCT IS LEAD FREE  
2µm MINIMUM MATTE TIN OVER 1.27 µm NICKEL UNDERPLATE
    - MANUFACTURING PROCESS COMPATIBILITY  
THE HOUSING WILL WITHSTAND EXPOSURE TO 260 °C ± 5 °C SOLDER BATH  
TEMPERATURE FOR 5 SECONDS IN A WAVE SOLDER APPLICATION WITH A 1.6mm  
THICK CIRCUIT BOARD.
    - LABELLING  
MEETS PACKAGING SPECS AS PER GS-14 - 920.
    - THIS PRODUCT MEETS EUROPEAN DIRECTIVES  
AND OTHER COUNTRY REGULATION AS DESCRIBED IN GS-2 2-008.

spec ref	-	dr	Sawanth, Ambaa	2020/12/08	projection	mm	size	A3	scale	5:1	
tolerance std	ISO 406 ISO 1101	eng	Detouillon, Da	2022/04/26			ecn no	ELX-F-44560-1			
TOLERANCES UNLESS OTHERWISE SPECIFIED		chr	-	-			rel level	Released			
surface	linear	appr	Wollin, Severi	2022/04/26	product family	-	dwg no	10078991		rev	B
ISO 1302	angular			cat. no.	-	Product - Customer Drw	sheet 1 of 2				

SIZE	POSITIONS	DIM A	DIM B
06	2x3	4.00	20.00
08	2x4	6.00	22.00
10	2x5	8.00	24.00
12	2x6	10.00	26.00
14	2x7	12.00	28.00
24	2x12	22.00	38.00
30	2x15	28.00	44.00
40	2x20	38.00	54.00
44	2x22	42.00	58.00
50	2x25	48.00	64.00

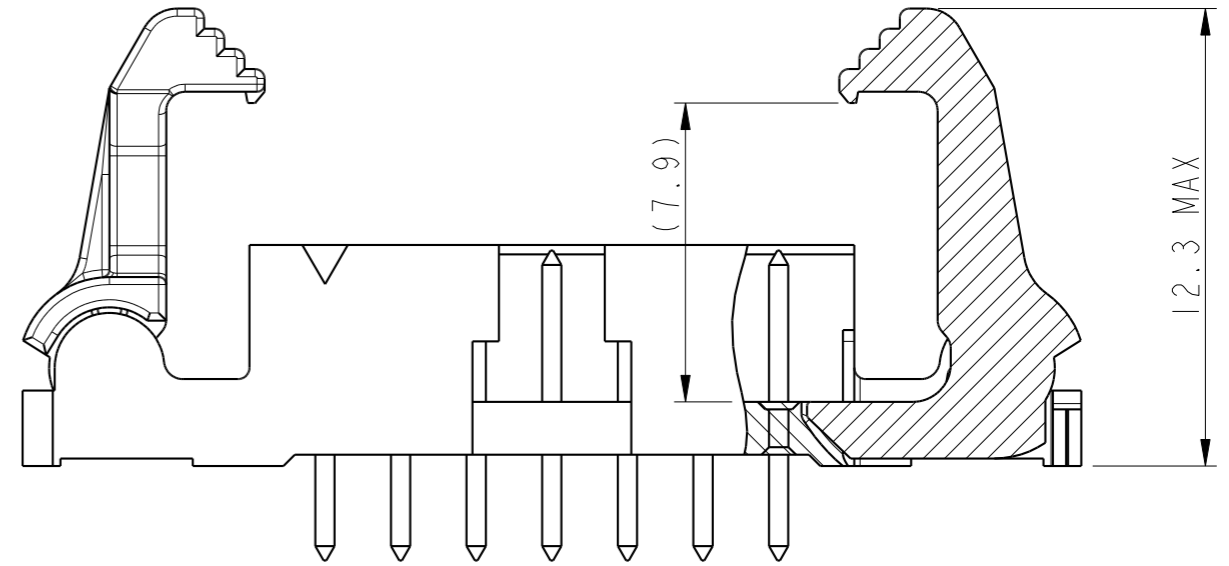
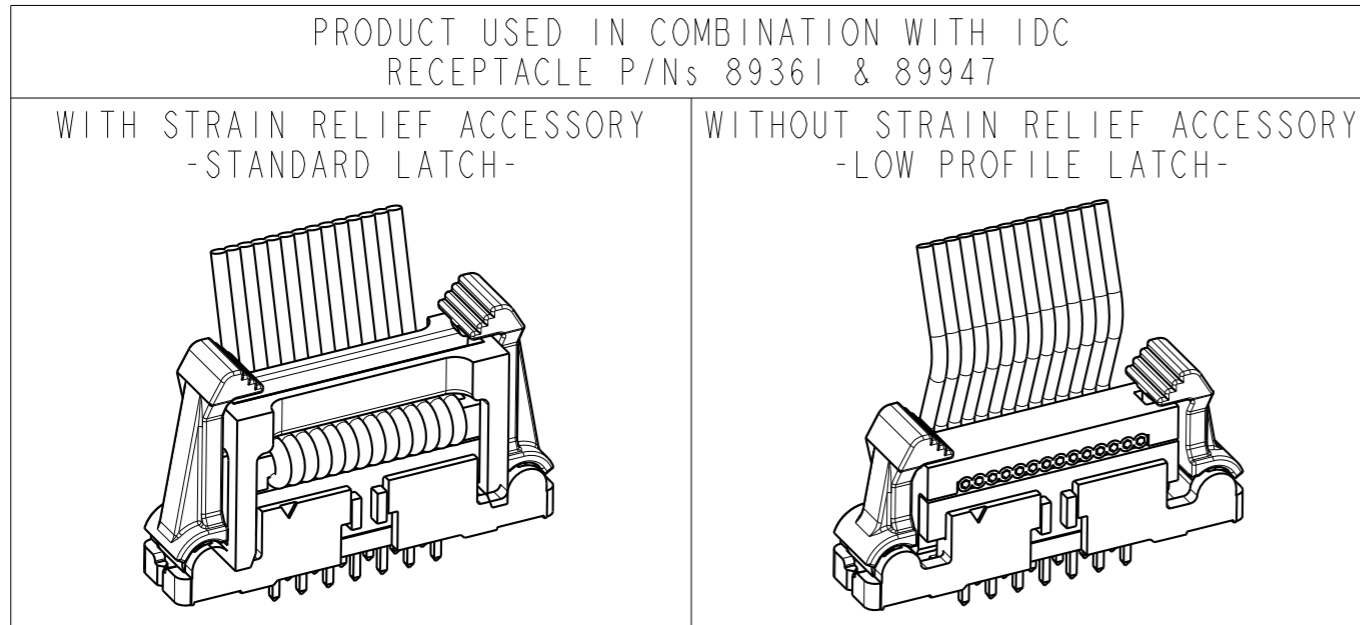
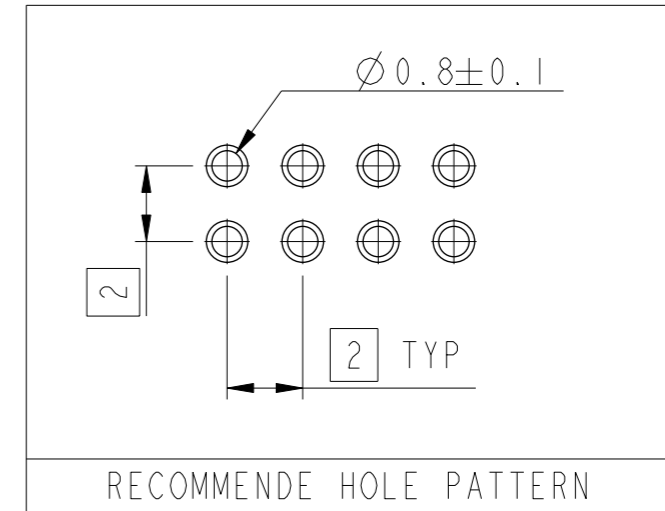
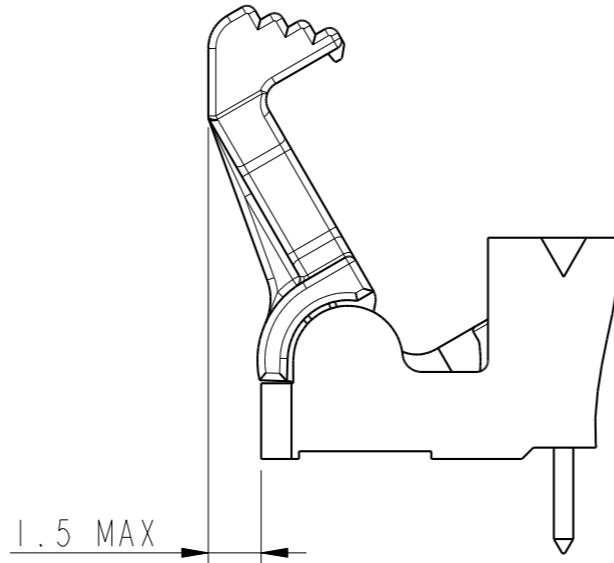

SECTION C-C  
EXAMPLE 10078991-G02-14YLF  
LOW PROFILE LATCH

spec ref	-	dr	Sawanth, Ambaa	2020/12/08	projection	mm	size	A3	scale	5:1
tolerance std	ISO 406 ISO 1101	eng	Detouillon, Da	2022/04/26		← →	ecn no	ELX-F-44560-1		
TOLERANCES UNLESS OTHERWISE SPECIFIED		chr	-	-			rel level	Released		
surface	linear	0.X	±0.3	<b>Amphenol FCI</b>	product family	-	dwg no	10078991		
		0.XX	±0.10		EJECT LATCH HEADER	rev	B			
	angular	0°	±2°		VERTICAL TMT	cat. no.	-	Product - Customer Drw	sheet 2 of 2	