

# BAS SERIES

006003  
Issue 1

## Battery Safety Aerosol Sensors CAN Communication Output

### DESCRIPTION

The BAS Series are automotive-grade aerosol sensors that use the principle of light scattering to detect and report thermal runaway events in lithium-ion battery packs. It detects the presence and concentration of aerosols such as smoke, liquid and debris that are early indicators of a thermal runaway event in an enclosed lithium-ion battery pack. The BAS Series measures and reports aerosol concentration from 200  $\mu\text{g}/\text{m}^3$  to 10000  $\mu\text{g}/\text{m}^3$  using CAN (Controller Area Network) communication protocol. They have a factory-programmed, thermal runaway warning threshold of 5000  $\mu\text{g}/\text{m}^3$ . These products are designed to meet higher quality and reliability requirements. The BAS series is RoHS compliant.

### CUSTOMIZATION

The BAS Series may be customized to better meet application needs. Solutions may be tailored to exact specifications for improved time to market, lower total system costs and enhanced reliability. For technical assistance, we provide global engineering and service support for your needs.

### OPERATING MODES

The sensor function in the following operating modes:

- **ECO Mode:** The sensor operates in ECO Mode when the request pin voltage is set to low. The sensor wakes up for 200 ms and hibernates for the remaining 12000 ms (typical) to reduce power consumption during each measurement cycle of 12200 ms (default value). In ECO Mode, CAN communication is disabled. If the sensor detects an aerosol concentration above the set threshold, a wake-up signal is sent to the BMS (Battery Management System) to initiate a full battery system check.
- **Continuous Mode:** The sensor operates in Continuous Mode when the request pin voltage is set to high by the BMS. CAN communication is enabled in Continuous Mode. In Continuous Mode, the sensor monitors and outputs the aerosol concentration to the BMS using CAN communication. The sensor may be switched to ECO Mode by setting the request pin voltage to low.

**NOTE:** The sensor default working mode is ECO mode.

### WORKING LOGIC FUNCTIONS

- **Request Signal:** The BMS controls the sensor's operating mode through the request pin of the sensor.
- **Wake-up Signal:** When the sensor detects that the aerosol concentration is above the threshold, the wake-up pin is set to high to wake up the BMS.

### TRANSPORTATION APPLICATIONS

Battery pack systems for electric vehicles and energy



### FEATURES

- High accuracy and low temperature drift
- CAN communication protocol
- Wake-up output and request input for high reliability system integration
- Aerosol threshold value of 5000  $\mu\text{g}/\text{m}^3$  allows early detection of thermal runaway events

### VALUE TO CUSTOMERS

- Early detection of thermal runaway has the potential to mitigate the loss of life and property
- The ECO mode enables continuous system monitoring in low power mode
- Thermal runaway detection sensor allows compliance with international regulations and recommendations
- Solutions may be tailored to exact specifications for improved time to market
- Lower total system cost and enhanced reliability



The BAS Series joins the Battery Monitoring Suite. To view the entire product portfolio, [click here](#).

**Honeywell**

# BATTERY SAFETY AEROSOL SENSORS BAS SERIES

**TABLE 1. GENERAL SPECIFICATIONS<sup>1</sup>**

Characteristic	Parameter
Operating temperature range	-40°C to 85°C [-40°F to 185°F]
Particulate matter measurement range	200 µg/m <sup>3</sup> to 10000 µg/m <sup>3</sup>
Accuracy	±15% at threshold concentration of 5000 µg/m <sup>3</sup>
Response time	≤1 s
Current consumption (average): ECO Mode Continuous Working Mode	<0.5 mA <30 mA
ECO Mode wake-up threshold	5000 µg/m <sup>3</sup>

<sup>1</sup> All specifications are at room temperature unless otherwise noted.

**TABLE 2. ELECTRICAL SPECIFICATIONS<sup>1</sup>**

Characteristic	Min.	Typ.	Max.	Unit
Supply voltage (Vs)	8	12	16	Vdc
Wake-up signal:				
High level voltage	8	12	16	Vdc
Low level voltage	—	—	0.5	Vdc
Output current	0.6	1.2	1.8	mA
REQUEST Input from from BMS to BAS:				
High level voltage	8	12	16	Vdc
Over voltage capability	—	—	24	Vdc
Reverse voltage capability	-14	—	—	Vdc

<sup>1</sup> All specifications are at room temperature unless otherwise noted.

**TABLE 3. COMMUNICATIONS SETTINGS**

Baud Rate	ID	Period	Length
500 kbps	0x667	1 s	8 Bytes

**TABLE 4. MESSAGE FORMAT**

Byte	Name	Definition
BYTE0	particulate matter concentration	—
BYTE1	particulate matter concentration	—
BYTE2	Low-Power Mode wake-up threshold	—
BYTE3	Low-Power Mode wake-up threshold	—
BYTE4	0-2	status 0x00 = normal 0x01 = alarm 0x02 = reserved
	3-7	fault 0x00 = normal 0x01 = photoelectric device fault 0x02 = Vs over voltage 0x03 = Vs under voltage others = reserved
BYTE5	0-3	rolling counter
BYTE6	4-7	—
BYTE7	CRC check code	

# BATTERY SAFETY AEROSOL SENSORS BAS SERIES

Figure 1. Operating Modes

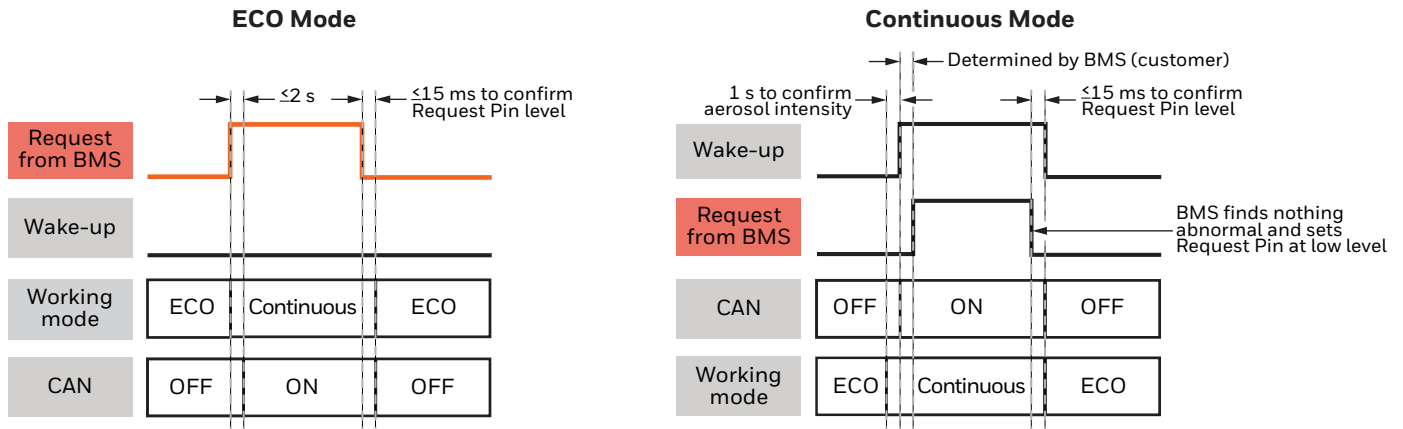

Figure 2. Interface Circuits

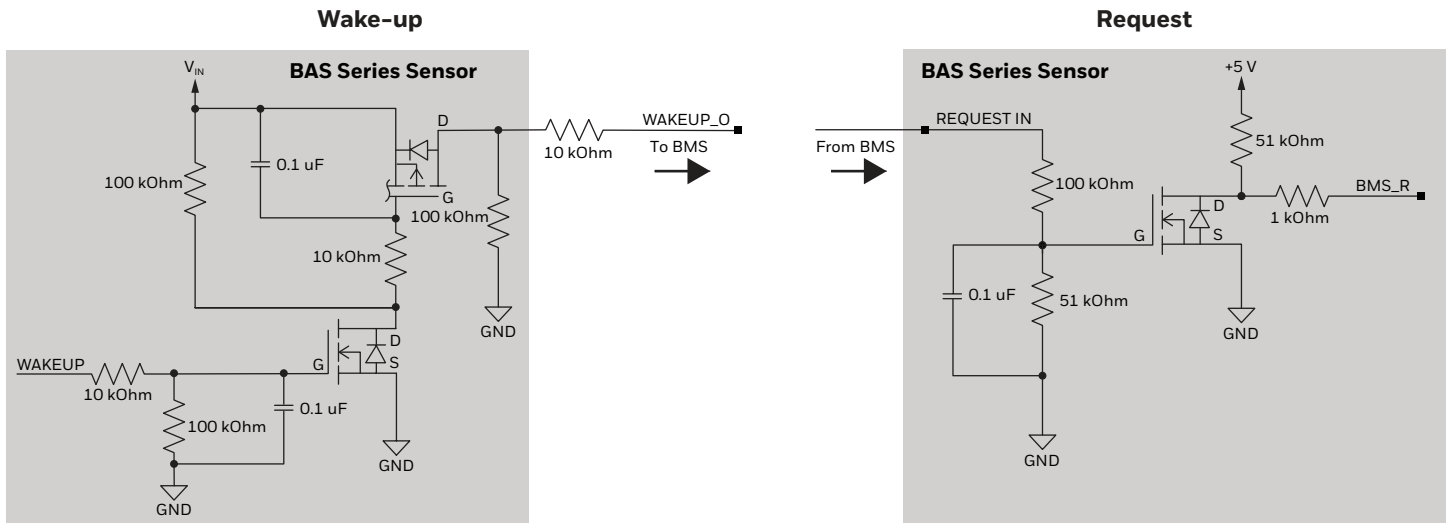

TABLE 5. WAKE-UP SIGNAL

Parameter	Min.	Typ.	Max.	Unit
High level voltage	8	12	16	Vdc
Low level voltage	—	—	0.5	Vdc
Output capability	6	12	18	mA

TABLE 6. REQUEST SIGNAL

Parameter	Min.	Typ.	Max.	Unit
High level voltage	8	12	16	Vdc
Low level voltage	—	—	0.5	Vdc

# BATTERY SAFETY AEROSOL SENSORS BAS SERIES

Figure 3. Nomenclature/Order Guide

For example, **BAS6C-X00** defines a BAS Series, battery aerosol sensor, six pins, CAN output signal, MCU1 version.

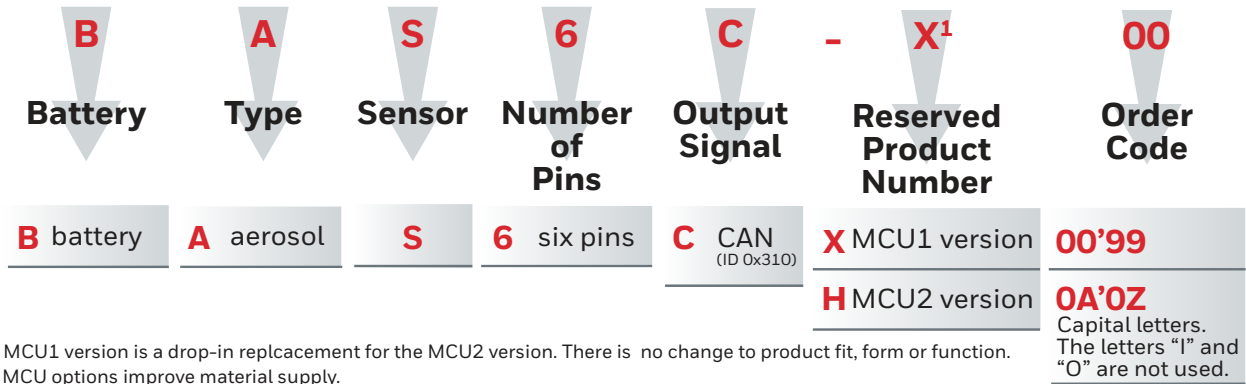

Figure 4. Mounting Dimensions (for reference only)

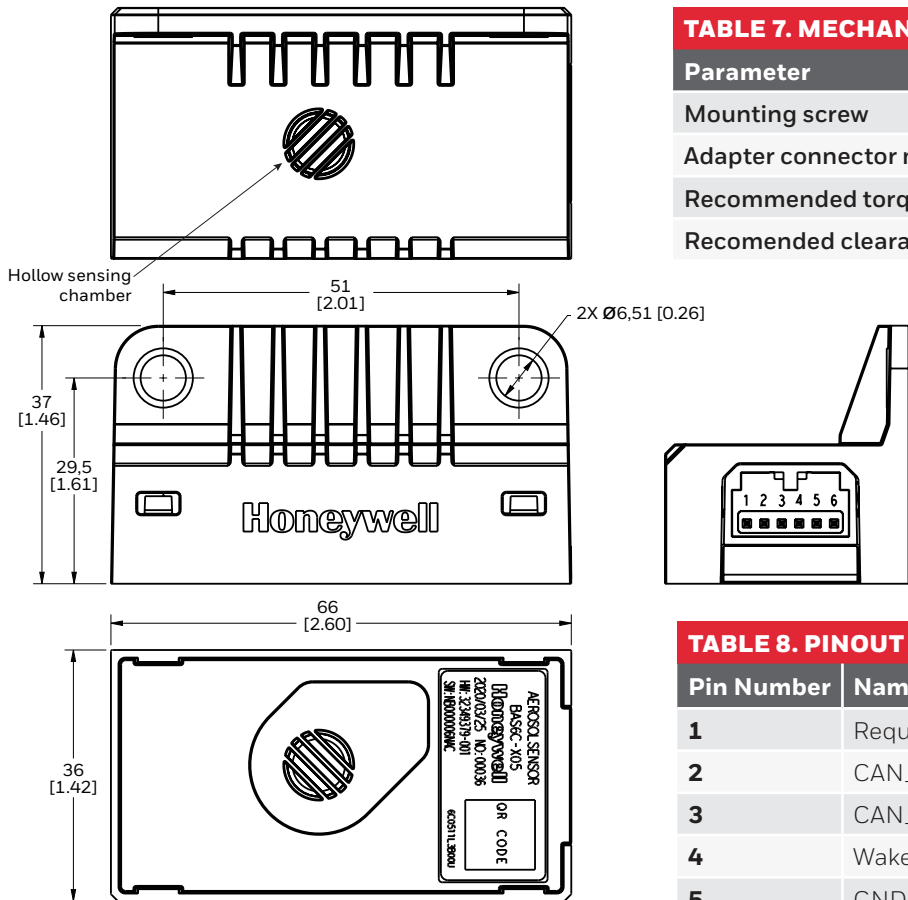

TABLE 7. MECHANICAL SPECIFICATIONS	
Parameter	Characteristic
Mounting screw	M6
Adapter connector model	175507-2
Recommended torque	10 Nm
Recommended clearance	10 cm

TABLE 8. PINOUT FOR CAN VERSIONS		
Pin Number	Name	
1	Request	Control working mode
2	CAN_L	CAN communication low
3	CAN_H	CAN communication high
4	Wake-up	Wake-up BMS
5	GND	Negative power supply
6	Vcc	Positive power level

TABLE 9. ORDER GUIDE	
Catalog Listing	Description
BAS6C-X00	BAS Series, battery safety aerosol sensor, six pins, CAN output signal, MCU1 version
BAS6C-H00	BAS Series, battery safety aerosol sensor, six pins, CAN output signal, MCU2 version

## WARRANTY/REMEDY

Honeywell warrants goods of its manufacture as being free of defective materials and faulty workmanship during the applicable warranty period. Honeywell's standard product warranty applies unless agreed to otherwise by Honeywell in writing; please refer to your order acknowledgment or consult your local sales office for specific warranty details. If warranted goods are returned to Honeywell during the period of coverage, Honeywell will repair or replace, at its option, without charge those items that Honeywell, in its sole discretion, finds defective.

**The foregoing is buyer's sole remedy and is in lieu of all other warranties, expressed or implied, including those of merchantability and fitness for a particular purpose. In no event shall Honeywell be liable for consequential, special, or indirect damages.**

## FOR MORE INFORMATION

Honeywell Sensing and Safety Technologies services its customers through a worldwide network of sales offices and distributors. For application assistance, current specifications, pricing or the nearest Authorized Distributor, visit our [website](#) or call:

USA/Canada	+1 302 613 4491
Latin America	+1 305 805 8188
Europe	+44 1344 238258
Japan	+81 (0) 3-6730-7152
Singapore	+65 6355 2828
Greater China	+86 4006396841

## Honeywell Sensing and Safety Technologies

830 East Arapaho Road  
Richardson, TX 75081  
[www.honeywell.com](http://www.honeywell.com)

## WARNING PERSONAL INJURY

DO NOT USE these products as safety or emergency stop devices or in any other application where failure of the product could result in personal injury.

**Failure to comply with these instructions could result in death or serious injury.**

## WARNING MISUSE OF DOCUMENTATION

- The information presented in this product sheet is for reference only. Do not use this document as a product installation guide.
- Complete installation, operation, and maintenance information is provided in the instructions supplied with each product.

**Failure to comply with these instructions could result in death or serious injury.**

While Honeywell may provide application assistance personally, through our literature and the Honeywell web site, it is buyer's sole responsibility to determine the suitability of the product in the application.

Specifications may change without notice. The information we supply is believed to be accurate and reliable as of this writing. However, Honeywell assumes no responsibility for its use.