

MC33742

System Basis Chip (SBC) with Enhanced High Speed CAN Transceiver

Applications

- Aircraft Systems
- Automotive Systems
- Robotic Systems
- Industrial Actuator Control
- Marine Applications
- Automotive Electronic Control Units including a High Speed CAN

Overview

The MC33742 and the 33742S are SPI-controlled System Basis Chips (SBCs) combining many frequently used functions along with a CAN 2.0-compliant transceiver, used in many automotive electronic control units (ECUs). The MC33742 SBC has a fully protected fixed 5.0 V low dropout internal regulator with current limiting, over-temperature pre-warning, and reset. A second 5.0 V regulator can be implemented using external pass PNP bipolar junction pass transistor driven by the SBC's external V2 sense input and V2 output drive terminals.

The SBC has four main operating modes: Normal, Standby, Stop, and Sleep mode. Additionally, there is an internally switched high side power supply output, four wake-up input terminals, a programmable window watchdog, interrupt, reset, and a SPI module for communication and control. The High Speed CAN 2.0 A /B transceiver is available for inter-module communication.

MC33742 Simplified Application Drawing

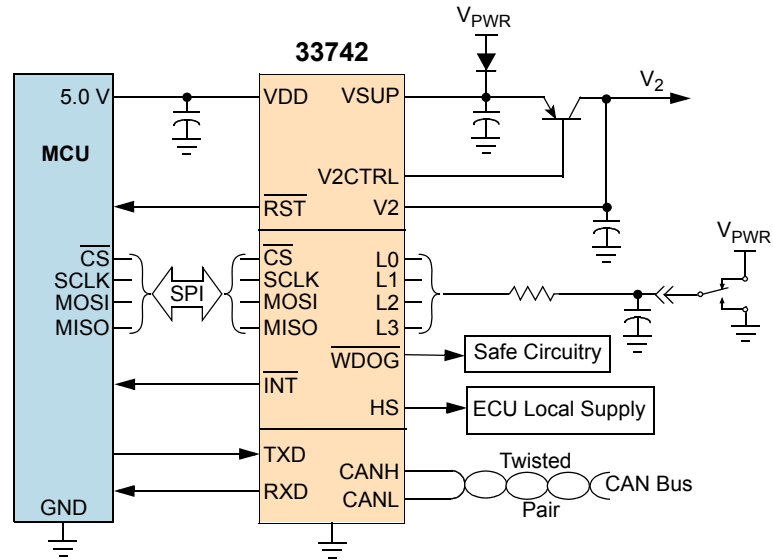

Performance	Typical Values
Operating Voltage	5.5 V to 18 V
Data Rate	1.0 Mbps
Internal 5.0 V Regulator	200 mA
External 5.0 V Series Regulator	200 mA
Supply Current with CAN Wake-up Enabled	
Supply Current in Sleep Mode, CAN in Sleep State with CAN Wake-up Enabled	53 + 12 = 65 μ A
Supply Current in Stop Mode, CAN in Sleep State with CAN Wake-up Enabled	80 + 12 = 92 μ A
Ambient Operating Temperature	-40°C \leq T _A \leq 125°C

Features

- High Speed 1.0 Mbps CAN interface with bus diagnostic capability (detection of CANH and CANL short to ground, to VDD, and to VSUP)
- Low-drop voltage 5.0 V, 200 mA VDD Regulator with current-limiting, over-temperature pre-warning, and output monitoring with reset
- Additional 5.0 V regulator with external series pass transistor
- Normal, standby, stop, and sleep modes with low sleep and stop mode current
- 150 mA high side switch output for control of external circuitry
- Four external wake-up inputs
- Software programmable watchdog window, interrupt, and reset

Benefits

- Standby current consumption reduced
- Flexible wake-up conditions and watchdog function
- Innovative CAN high speed diagnostic with failure mode sent to the MCU through SPI interface
- Simple system design with direct interfacing to a microprocessor
- Reduced PC board space resulting in enhanced application reliability
- Economical solution with an optimized performance/cost ratio
- Simplified MCU power supply design with internal safety features and output voltage supervisory circuits

Freescall offers a complete line of compatible system basis chips with transceivers

Protection	Detect	Limiting	Shut Down	Auto Retry	Status Reporting
VDD					
Under-voltage	•				
Over-temperature	•	•		•	•
Over-current	•		•		•
Short-circuit	•		•		
V2					
Under-voltage	•	•			
HS					
Over-temperature	•	•			•
Over-current			•		
CAN Bus Fail Detection					
CANH/L Short-to-Battery	•		•	•	•
CANH/L Short-to-Ground	•		•	•	•
CANH/L Short-to-V _{DD}	•		•	•	•
Battery Line					
Under-voltage	•				•
Battery Disconnect	•				•

Simplified Internal Block Diagram

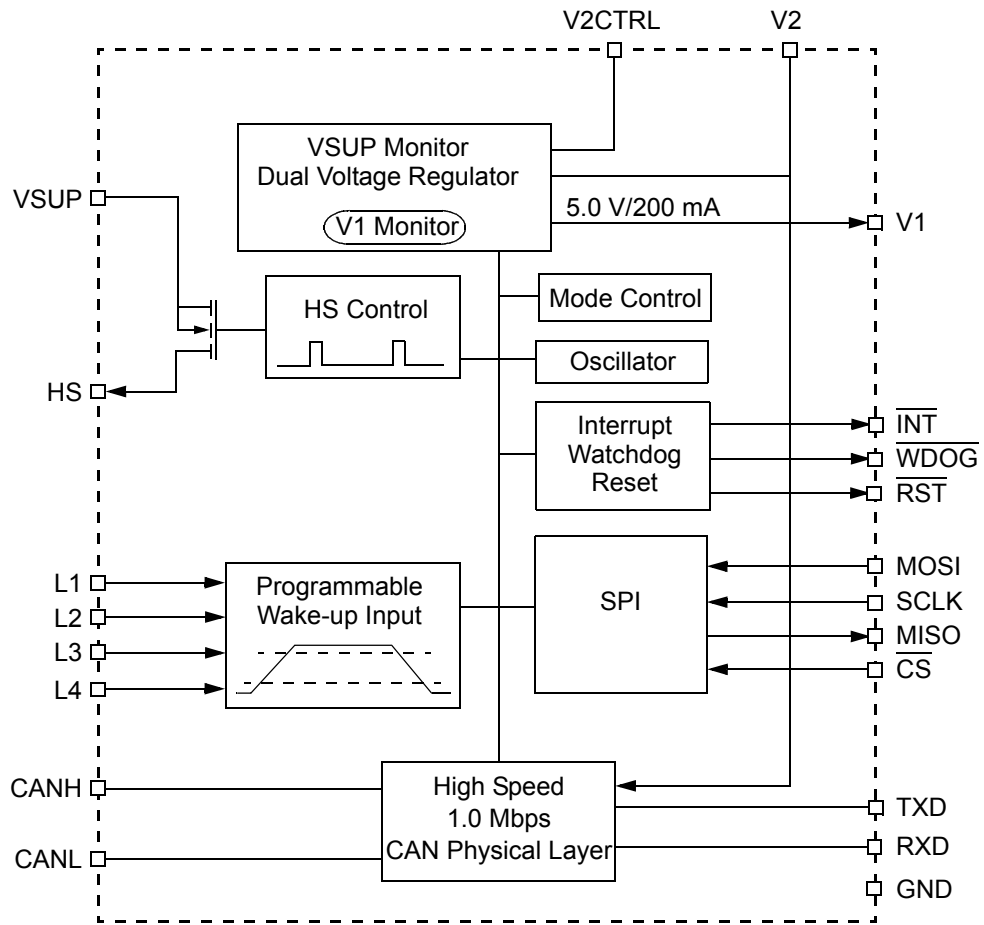

Questions

- Q: Are you looking for a complete, easy-to-design power supply solution for your embedded system?
- Q: Do you need an advanced microcontroller power supply with power sequencing and supervisory functions?
- Q: What voltage (5.0 V or 3.3 V) does your microcontroller need?
- Q: What type of CAN (high/low speed) do you need?
- Q: Do you need several power supplies?
- Q: Do you need a fully protected low drop series pass regulator?
- Q: Would you like to monitor BUS failure during a high speed CAN communication?
- Q: Do you want to reduce your application current consumption in standby mode?
- Q: How many wake-up inputs do you need?
- Q: Do you need a watchdog with independent reset/interrupt capability?

Ordering Information

Part Number	Temperature Range	Package
MC33742EP/R2	-40°C to 125°C	48 QFN (Pb-Free)
MCZ33742EG/R2	-40°C to 125°C	28 SOICW (Pb-Free)
MCZ33742SEG/R2	-40°C to 125°C	28 SOICW (Pb-Free)

Development Tools

Part Number	Description
KIT33742DWEVB	Evaluation Kit

Documentation

Document Number	Title	Description
MC33742	Data Sheet	Presents the specifications for the product
SG1002	Selector Guide	Analog and power management device comparison
SG187	Selector Guide	Automotive device comparison

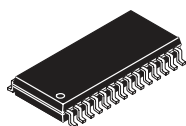

28 SOICW
1.27 mm Pitch
18.0 mm x 7.5 mm Body

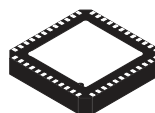

(Bottom View)
48 QFN
0.5 mm Pitch
7.0 mm x 7.0 mm Body