

AV/AVH-Series

Sealed Anti-Vandal Pushbutton Switches

PRODUCT WEBPAGE

request sample, configure part, watch video

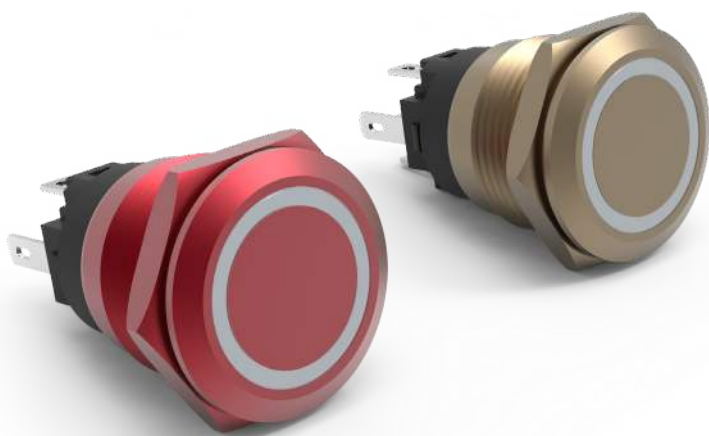

The AV/AVH-Series sealed switch product line features a sleek design with various LED illumination options. The bushing/button is available in stainless steel, or black, red and gold anodized. These single-pole switches are available with momentary and maintained circuits, with quick connect tab terminals for easy installation and daisy-chaining.

1	3-30	6-48	IP67 Sealing
Pole	Amps	VDC	Above-Panel

Typical Applications

- Marine
- Security Panels
- Traffic Signals
- Harsh and/or
- Industrial Controls
- Public Transit Systems
- Emergency Phones
- Outdoor Environments

Tech Specs

AV-Series

Electrical

Contact Rating	10.1A Resistive @ 12VDC
LED Ratings	12 VAC/DC @ 15mA
Dielectric Strength	1000V RMS 50-60 Hz
Insulation Resistance	50 M-ohms min. @500V DC
Initial Contact Endurance	≤10 mΩ
Electrical Endurance	Up to 25K Cycles
Contacts	Silver alloy
Terminals	110" x 0.020 [2.79 x 0.5 mm] plug-in terminal, copper alloy silver plate.

Physical

Function	NO / NC contact (changeover)
Operation	Momentary or maintained
Illumination	Independent LED (Red, Green, Amber, White, Blue)
Seals	Silicone, Bezel and Button
Mounting	M19-P1.0 Nut (SUS316), Tightening torque: 2~3Nm
Base	Glass filled Nylon
Actuator	Stainless Steel 316 or Aluminum Anodized
Lens	Polycarbonate, PC
Bushing	Stainless Steel 316 or Aluminum Anodized
Actuation Force	7N max
Weight	18g

Mechanical

Endurance	10,000 ON-OFF operations @ 6 per minute; with rated current & voltage.
Trip Free	All D-Series circuit breakers will trip on overload, even when actuator is forcibly held in the ON position.
Trip Indication	The operating actuator moves positively to the OFF position when an overload causes the breaker to trip.

Environmental

Storage Temperature	-55°C to +85°C
Operating Temperature	-30°C to +70°C (may affect endurance)
Vibration, High Frequency	Mil-Std 202G, Method 204D, Test Condition A 0.06 DA or 10G' s 10-500 Hz. Test criteria- No loss of circuit during test and pre and post test contact resistance.
Vibration, Random	Mil-Std 202G, Method 214A, Test Condition I and B 7.56G' s RMS. 8-hours in each of the 3 mutually perpendicular axes. Test criteria- No loss of circuit during test and pre and post test contact resistance.
Thermal Shock	MIL-STD 202G Method 107G, Condition A (Five cycles @ -55°C to +25°C to +85°C to +25°C)
Moisture Resistance	MIL-STD 202G Method 106G, i.e. 10-24-hour cycles @ +25°C to +60°C, 80-90% RH.
Sealing	IP67, for above-panel components of the actual switch; compliant with IEC 60529.
Ignition Protection	UL1500, ISO 8846, SAE J1171
Electro-Static Discharge	Compliant with EN61000-4-2 Discharge Level: Max. ±8KV; Discharge Level: Max. ±15KV

Ordering Scheme

Sample Part Number AV 1 - 1 A 2 1 1 A - R 00

Selection 1 2 3 4 5 6 7 8 9 10

1. SERIES

AV Anti-Vandal Pushbutton Switch

2. MOUNTING

1 M19 Threaded Bushing

3. MATERIAL / FINISH

1 Stainless Steel Bushing / Button
2 Black Anodized Bushing / Button
3 Red Anodized Bushing / Button
4 Gold Anodized Bushing / Button

4. CIRCUIT

A Momentary NC / NO **B** Maintained NC / NO

5. RATING

2 10.1A Resistive, 12VDC **3** 10.1A Resistive, 24VDC

6. TERMINATION

1 .110" Quick Connect Tabs - Silver Plated

7. LENS / BUTTON

1 Flush

8. LED COLOR

N No LED **B** Green **D** White
A Red **C** Amber¹ **E** Blue

9. ILLUMINATION STYLE

N None **R** Ring

10. AGENCY APPROVAL

00 No Legend **02** Stand By **03** Light **04** Bell
01 On/Off **05** Door Open **06** Information **07** Horn



Notes:

1. Only available with rating 2

[Configure Complete Part Number >](#)

Dimensional Specs

inches [millimeters]

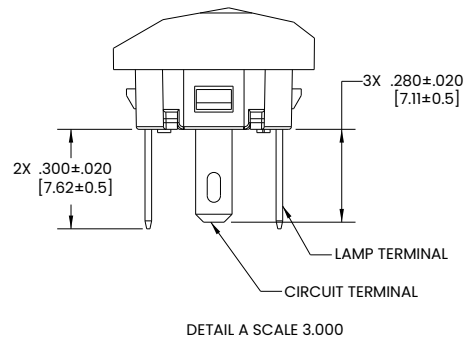
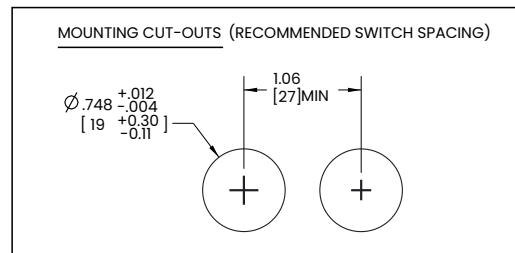
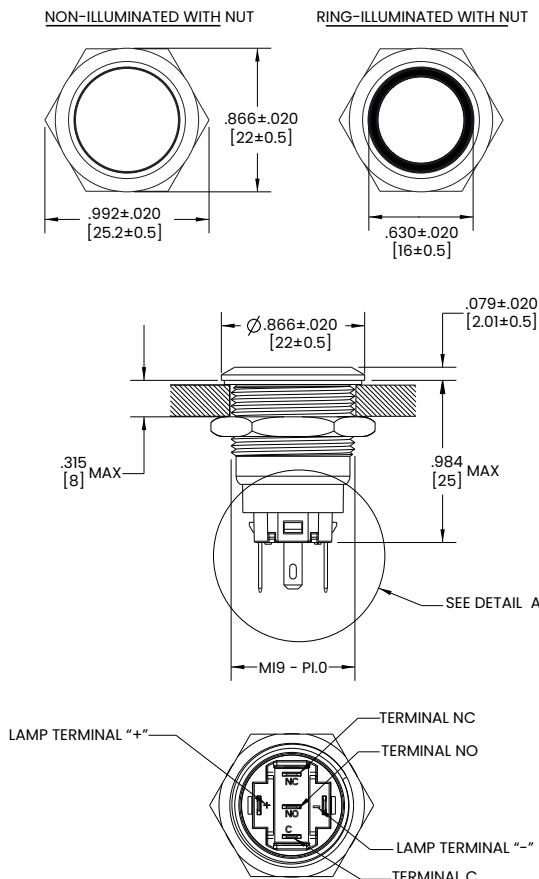

Tech Specs

AVH-Series

Electrical

Supply Voltage Range	9VDC – 16VDC
Overtemp. Protection	≥150°C (SmartFET temperature), Latched status signal
Reverse Polarity Protection	16 VDC
Insulation Resistance	50 M-ohms min. @500VDC
Initial Contact Resistance	≤10 mΩ
Electrical Endurance	Up to 50K Cycles

Circuit B (High-Current Latching) 1

Current Rating	20A 12VDC, 80A surge (300 ms), 14 AWG lead wire 30A 12VDC, 100A surge (300 ms), 12 AWG lead wire Function ON / OFF
Function	ON / OFF
Overload Protection	≥135A, Output does not function. Switch reset by cycling through OFF position (unless overload continues).
Connections	14AWG, 12 AWG Lead Wire (20A, 30A, respectively), 6" Lg. 0.187" PC Quick Connect Terminal Ground Connection.

Circuit C (Nav-Anchor) 2

Current Rating	10A total, 5A each Output; 10A surge each Output (300 ms)
Function	NAV-ANC, First press: Load 1 ON & Load 2 ON, Red Ring Illuminated Second press: Load 1 ON, Load 2 OFF, Blue Ring Illuminated Third Press: OFF
Overload Protection	≥60A, Output does not function Switch reset by cycling through OFF position (unless overload continues).
Connections	16AWG, 5A per Output, 6" Lg. 0.187" PC Quick Connect Terminal Ground Connection.

Circuit D (Dual-Output) 2

Current Rating	10A total, 5A each Output; 10A surge each Output (300 ms)
Function	First press: OFF Second press: Load 1 ON, Load 2 OFF, Red Ring Illuminated Third Press: Load 1 OFF, Load 2 ON, Blue Ring Illuminated.
Overload Protection	≥60A, Output does not function Switch reset by cycling through OFF position (unless overload continues).
Connections	16AWG, 5A per Output, 6" Lg. 0.187" PC Quick Connect Terminal Ground Connection.

Physical

Operation	Push button, Momentary (Circuit C & D), Maintained (Circuit B)
Illumination	Dependent LED
Seals	Gasket, bezel silicone, potted housing
Mounting	M19-P1.0 Nut, Tightening torque: 2-3Nm
Housing	Aluminum 6061 T6, Anodized per MIL-STD-8625, Type II, Class 2; Black
Actuator	Stainless steel 316 or Aluminum Anodized
Lens	Polycarbonate, PC
Bushing	Stainless steel 316 or Aluminum Anodized
Actuation Force	7N max
Weight	45-50g

Environmental

Storage Temperature	-55°C to +85°C
Operating Temperature	-30°C to +70°C (may affect endurance)
Vibration	Mil-Std 202G, Method 204D, Test Condition A 0.06 DA or 10G' s 10-500 Hz. Test criteria - No loss of circuit during test and pre and post contact resistance.
Vibration, Random	Mil-Std 202G, Method 214A, Test Condition I and B 7.56G' s RMS. 8-hours in each of the 3 mutually perpendicular axes. Test criteria - No loss of circuit during test and pre & post test contact resistance.
Shock	Mil-Std 202G, Method 213B, Test Condition K @ 30g's, 11ms normal duration. No resistance value loss pre and post test and no function malfunction. No loss of contact or unintended contact making.
Thermal Shock	MIL-STD 202G Method 107G, Condition A (Five cycles @ -55°C to +25°C to +85°C to +25°C)
Moisture Resistance	MIL-STD 202G Method 106G, i.e. 10-24-hour cycles @ +25°C to +60°C, 80-90% RH.
Sealing	IP67, for above-panel components of the actual switch compliant with IEC 60529.
Ignition Protection	UL1500, ISO 8846, SAE J1171

Notes:

- 1 The switch was designed to directly control the load and is not recommended for any application where the load may be removed via another switch.
- 2 For backfeed protection, it is recommended to use a diode in series for pump control circuits as shown below.

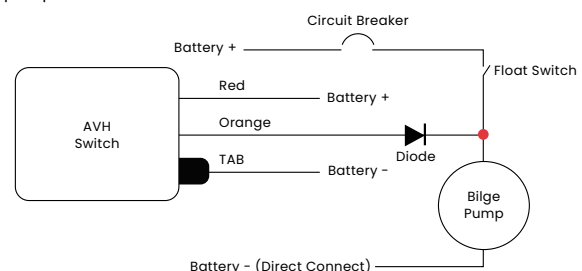

Ordering Scheme

Sample Part Number AVH 1 - 1 B 2 6 - R E N A

Selection 1 2 3 4 5 6 7 8 9 10

1. SERIES

AVH Anti-Vandal High Current Pushbutton Switch

2. MOUNTING

1 M19 Threaded Bushing

3. MATERIAL / FINISH

1 Stainless Steel Bushing / Button
2 Black Anodized Bushing / Button
3 Red Anodized Bushing / Button
4 Gold Anodized Bushing / Button

4. CIRCUIT

1,2
B ON - OFF (Output 1 - None) Maintained
C ON - ON - OFF (Output 1&2 - Output 1 - None) Momentary
D OFF - ON - ON (None - Output 1 - Output 2) Momentary

5. RATING

3
1 30A 12VDC
2 20A 12VDC
3 5A 12VDC (Per Output) / 10A 12VDC (Total)

6. WIRE LENGTH

6 6 inches (152.4 mm) with 0.187" (4.8mm) Ground Tab Terminal

7. ILLUMINATION STYLE

4
N None **R** Ring

8. POSITION 1 LED COLOR

8
N No LED **B** Green **D** White
A Red **C** Amber **E** Blue

9. POSITION 2 LED COLOR

5,6
N No LED **E** Blue

10. ILLUMINATION TYPE

7
N None
A Dependent (LED illuminates when the specified output is "ON")

Notes:

- Circuit code B requires rating code 1 or 2 only.
- Circuit codes C & D require rating code 3.
- Rating will determine the wire gauge used.
- Illumination Style code N requires: Position 1 LED Color N; Position 2 LED Color code N; Illumination Type code N.
- Circuit codes C & D require Position 2 LED color E.
- Circuit code B requires Position 2 LED Color code N.
- Other lighting options available: Consult Manufacturer.
- Circuits C & D require Position 1 LED color to be A or B.

[Configure Complete Part Number >](#)

Dimensional Specs

inches [millimeters]

NON-ILLUMINATED WITH NUT

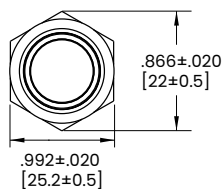

RING-ILLUMINATED WITH NUT



MOUNTING CUT-OUTS (RECOMMENDED SWITCH SPACING)

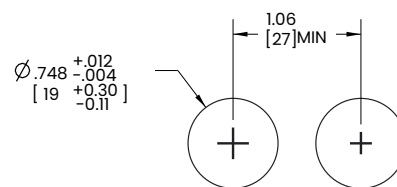

CIRCUIT B

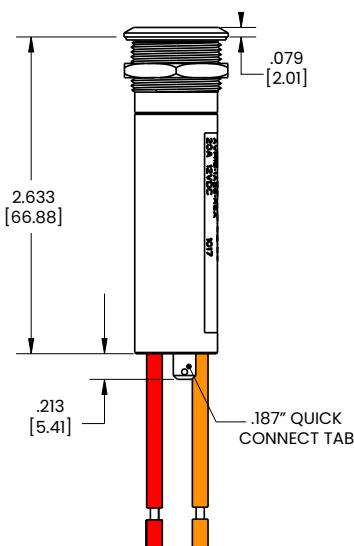

CIRCUIT C

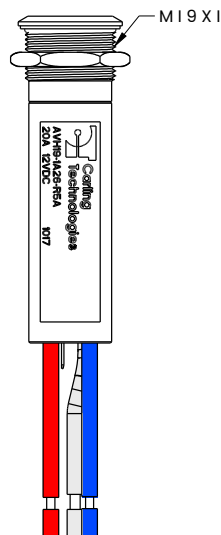

CIRCUIT D

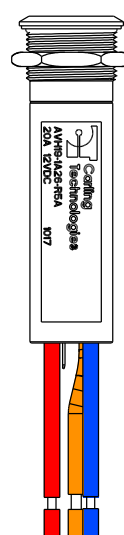

CIRCUIT B: BATTERY (+): RED WIRE
 LOAD 1: ORANGE WIRE
 GROUND: TAB OR BLACK

CIRCUIT C: BATTERY (+): RED WIRE
 LOAD 1: BLUE WIRE
 LOAD 2: WHITE WIRE
 GROUND: TAB

CIRCUIT D: BATTERY (+): RED WIRE
 LOAD 1: BLUE WIRE
 LOAD 2: ORANGE WIRE
 GROUND: TAB

Authorized Sales Representatives and Distributors

Click on a region of the map below to find your local representatives and distributors or visit www.carlingtech.com/findarep.



About Carling

Founded in 1920, Carling Technologies is a leading manufacturer of electrical and electronic switches and assemblies, circuit breakers, electronic controls, power distribution units, and multiplexed power distribution systems. With six ISO9001 and IATF16949 registered manufacturing facilities and technical sales offices worldwide, Carling Technologies Sales, Service and Engineering teams do much more than manufacture electrical components, they engineer powerful solutions! To learn more about Carling please visit www.carlingtech.com/company-profile.

To view all of Carling's environmental, quality, health & safety certifications please visit www.carlingtech.com/environmental-certifications.

© Carling Technologies, Inc.

6. Carling is a registered trademark of Carling Technologies, Inc. in the U.S. and other countries.