

THIS DRAWING IS UNPUBLISHED. RELEASED FOR PUBLICATION -,-  
 © COPYRIGHT - By - ALL RIGHTS RESERVED.

LOC	DIST	REVISIONS				
P	LTR	DESCRIPTION	DATE	DWN	APVD	
AF	50	F1	ECR-13-017177	05NOV13	PKS RRP	

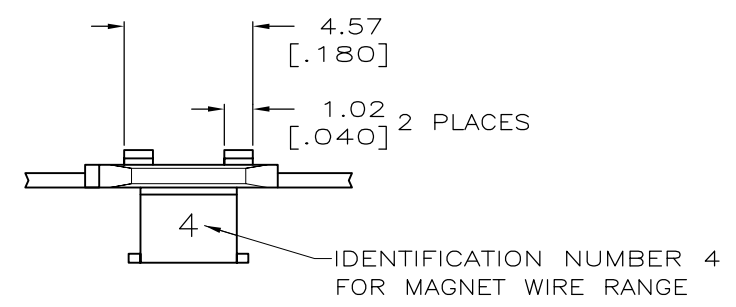

- 1 CONTINUOUS STRIP ON REELS WITH TERMINALS LOCATED ON 8.38±0.08 [.330±.003] CENTERS.
- △ SLOT ACCEPTS 0.18-0.23mm [#33-#31] AWG COPPER MAGNET WIRE.
- 2 WIRES OF THE SAME SIZE MAX PER SLOT.
- 3 TIN PLATED PER MIL-T-10727

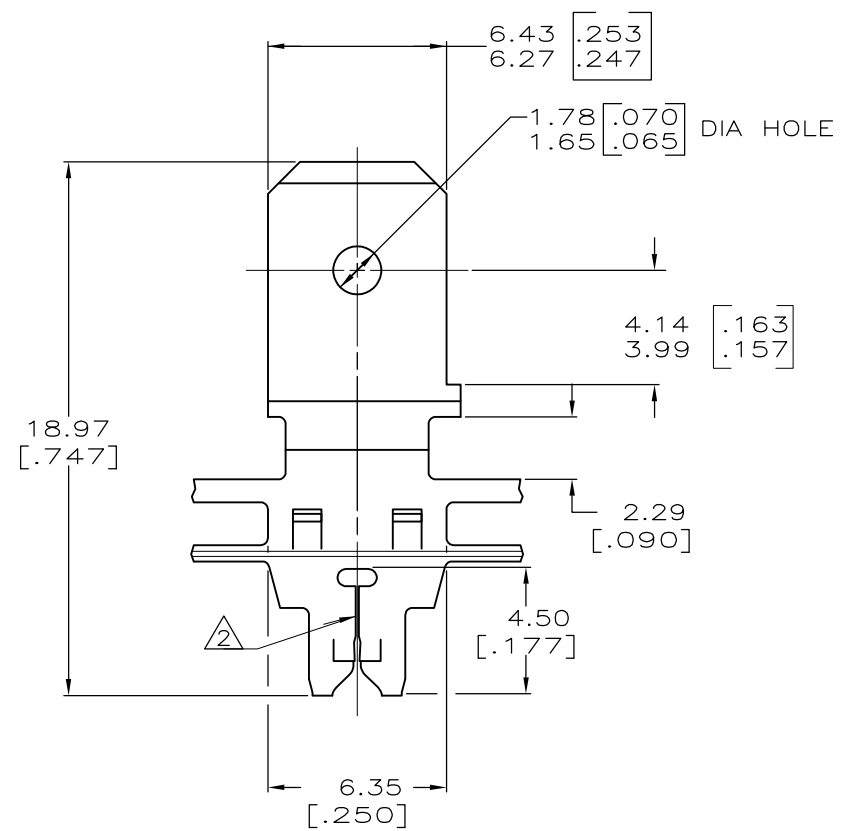
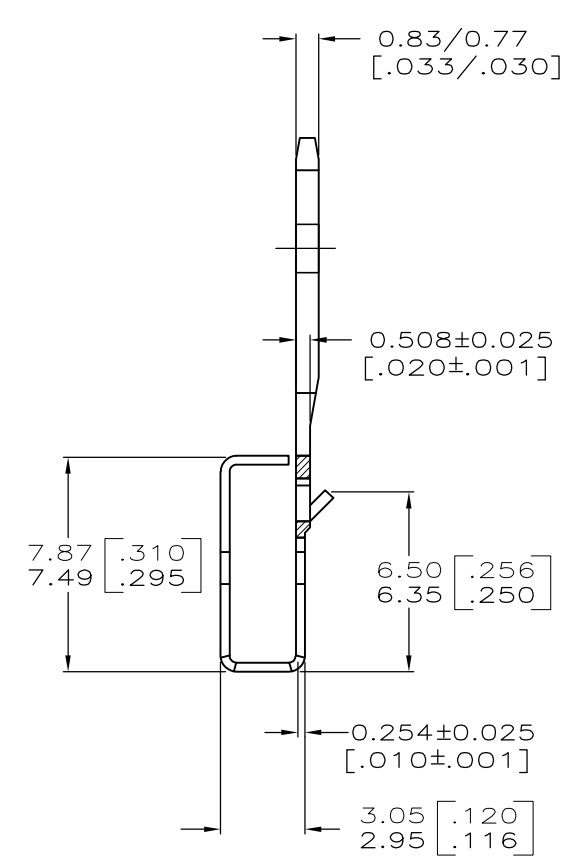
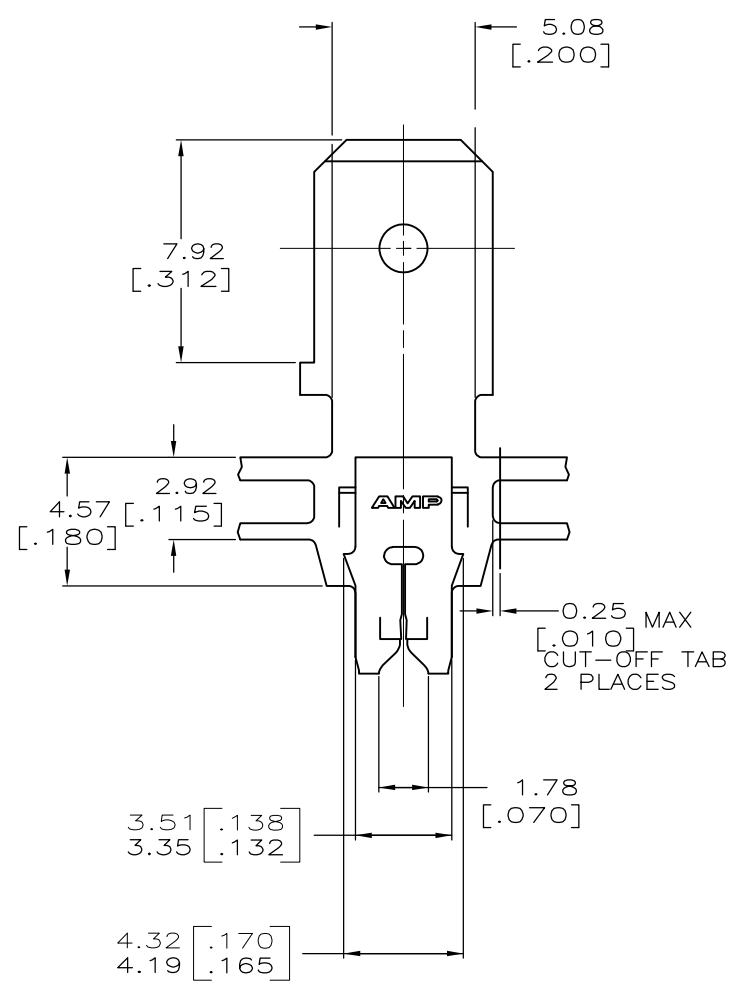

082 BRASS	63309-2
4M BRASS	63309-1
MATERIAL	PART NO.

THIS DRAWING IS A CONTROLLED DOCUMENT.		DWN 10/AUG/94 MICHAEL S. FEHER		
DIMENSIONS: mm		CHK 12/AUG/94 RAY R. BUCHHEISTER		
TOLERANCES UNLESS OTHERWISE SPECIFIED:		APVD 15/AUG/94 NELSON E NEFF	NAME TAB, 6.35 [.250] FASTON, MAG-MATE	
0 PLC ± -		PRODUCT SPEC 108-2012	SIZE CAGE CODE DRAWING NO RESTRICTED TO	
1 PLC ± -		APPLICATION SPEC 114-2094	A300779 C-63309	
2 PLC ± 0.25 [.010]		WEIGHT -	SCALE 6:1 SHEET 1 of 1 REV F1	
3 PLC ± -		CUSTOMER DRAWING		
4 PLC ± -				
ANGLES ± -				
MATERIAL BRASS	FINISH TIN PLATED			