

Boundary Conduction Mode

# Power Factor Correction Controller IC

**BD7695FJ BD7696FJ**

**General Description**

BD7695FJ and BD7696FJ are Power Factor Correction ICs for AC/DC supply, which are suitable for all products needing power factor improvement. The PFC adopts boundary conduction mode (BCM) and switching loss reduction and noise reduction are possible by Zero Current Detection (ZCD). This IC incorporates a circuit for reducing total harmonics distortion (THD) and can support IEC61000-3-2 Class-C.

**Key Specifications**

- Input VCC Voltage Range: 12 V to 38 V
- Operating Current: 0.60 mA (Typ)
- Operating Temperature Range: -40 °C to +105 °C

**Package**  
SOP-J8

**W (Typ) x D (Typ) x H (Max)**  
4.9 mm x 6.0 mm x 1.65 mm

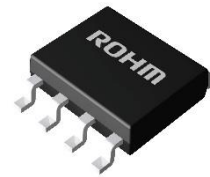

**Features**

- Boundary Conduction Mode PFC
- Low THD Circuit Incorporation
- Low Power Consumption
- VCC UVLO Function
- ZCD by Auxiliary Winding
- Static OVP by the VS Pin
- Error Amplifier Input Short Protection
- Stable MOSFET Gate Drive
- Soft Start

**Lineup**

Product name	Brown Out
BD7695FJ-E2	-
BD7696FJ-E2	○

**Applications**

- Lighting Equipment, AC Adopter, TV, Refrigerator, etc.

**Typical Application Circuit**

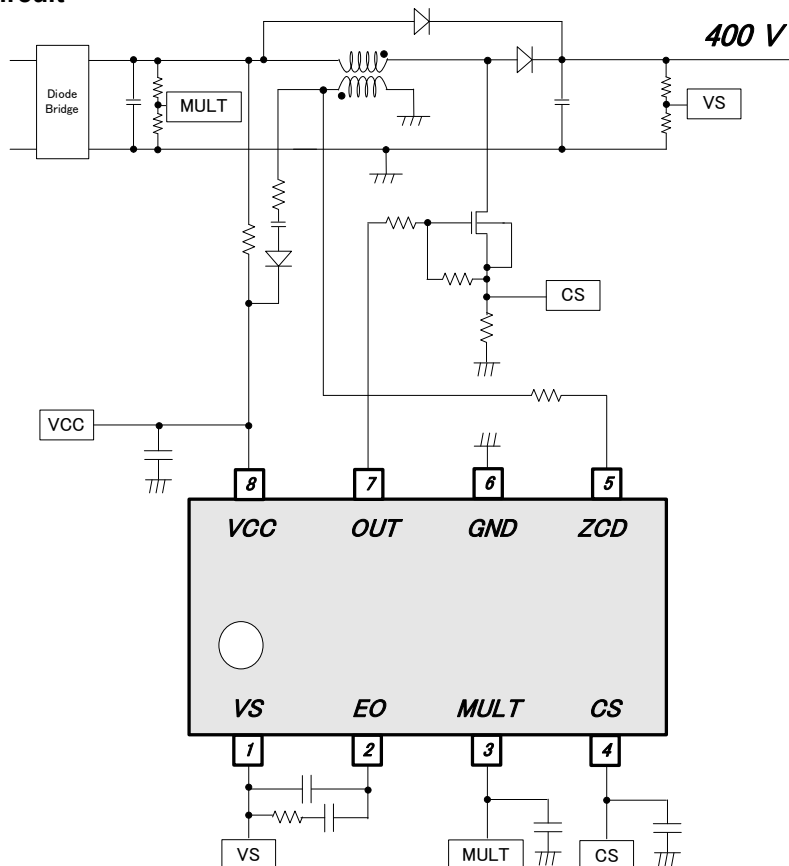

○Product structure : Silicon integrated circuit ○This product has no designed protection against radioactive rays.

Pin Configuration

(TOP VIEW)

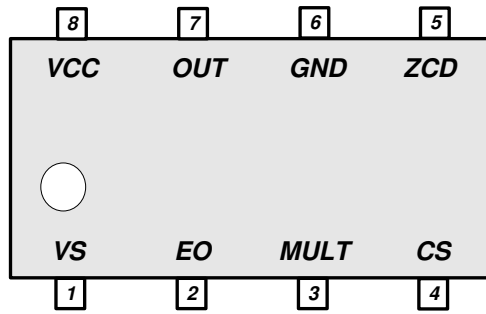

Pin Description

Pin No.	Pin Name	I/O	Function	ESD Diode	
				VCC	GND
1	VS	I	Feedback input pin	-	○
2	EO	O	Error amplifier output pin	-	○
3	MULT	I	Multiplier input pin	-	○
4	CS	I	Over current detection pin	-	○
5	ZCD	I	Zero current detection pin	-	○
6	GND	-	GND pin	○	-
7	OUT	O	External MOSFET driver pin	-	○
8	VCC	I	Power supply pin	-	○

Block Diagram

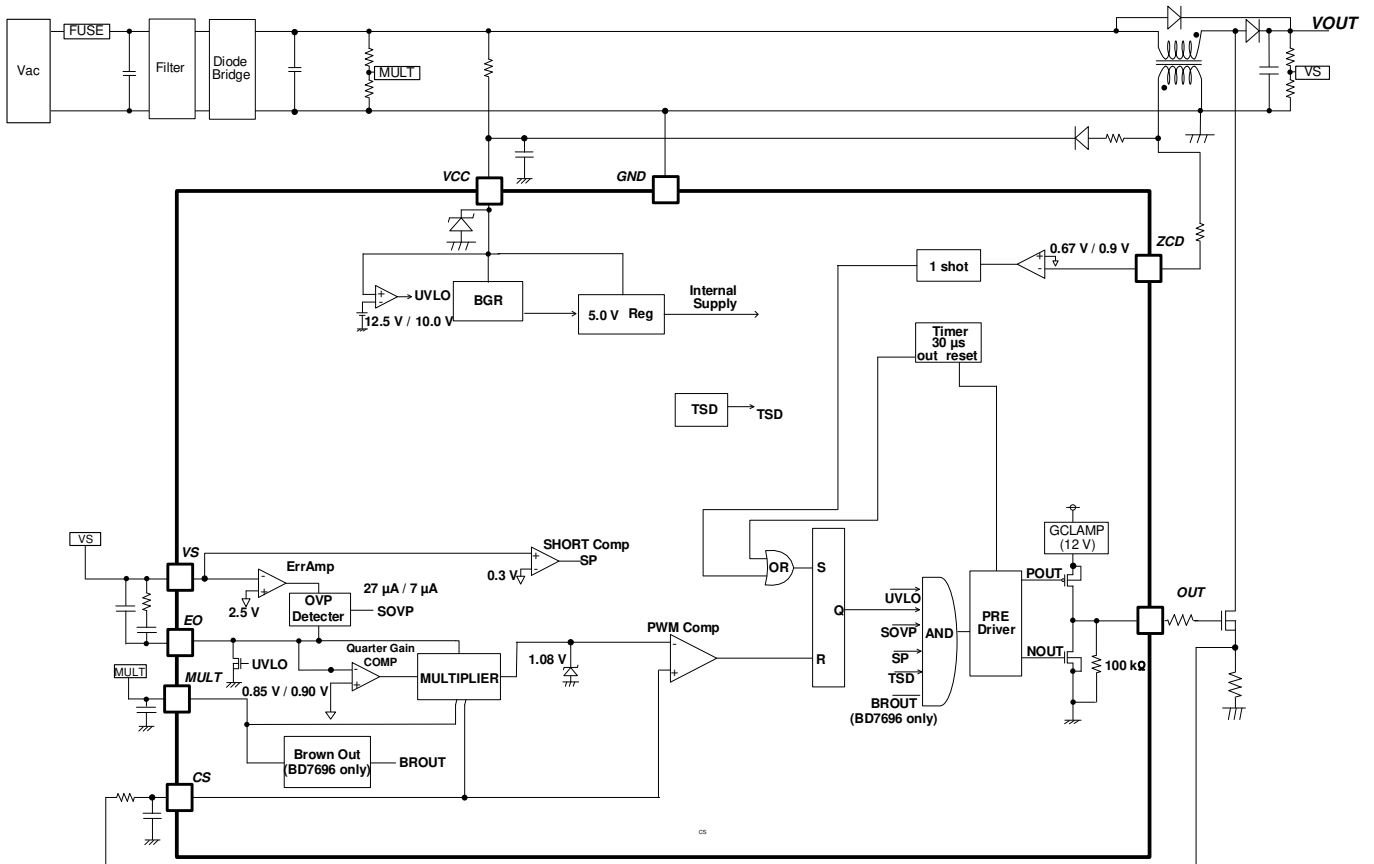

Description of Blocks

1 VCC Protection

This IC has VCC UVLO (Under Voltage Lock Out) of the VCC pin. Switching stops at the time of the VCC voltage fall. In addition, when the VCC voltage becomes higher than the  $V_{CC\_DIS1}$  (38 V Typ) voltage, it increases operating current and suppresses the rise in VCC voltage. When the VCC voltage is lower than the  $V_{CC\_DIS2}$  (34 V Typ) voltage, the operating current becomes usual. This function assumes the case that the VCC voltage rises by startup resistance.

2 PFC: Power Factor Correction

The power factor improvement circuit is a voltage control method in the Boundary Conduction Mode. The outline of the operation circuit diagram is shown in Figure 1. The switching operation is shown in Figure 2.

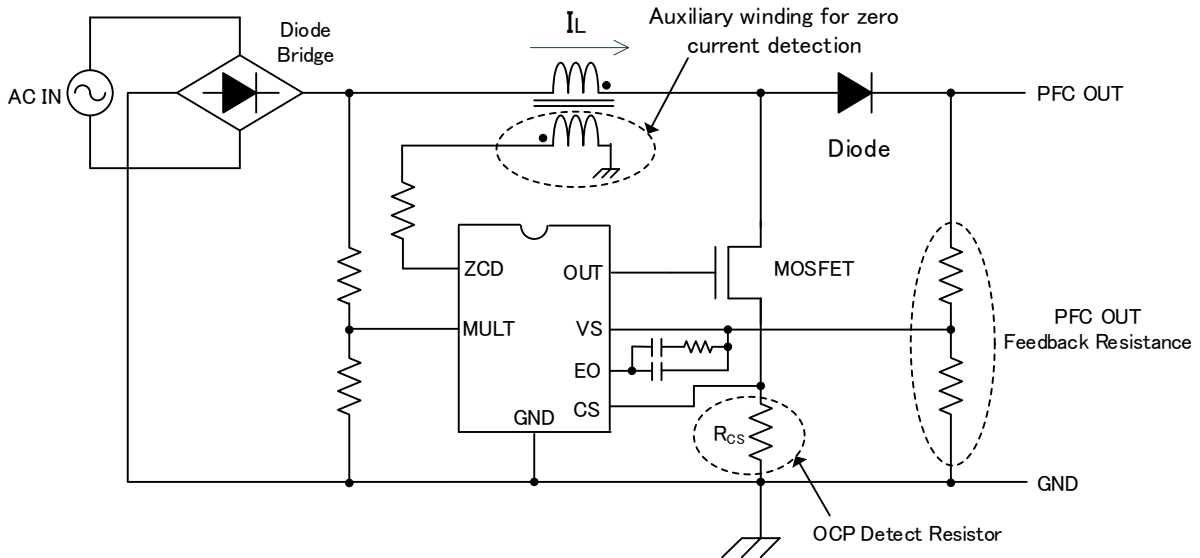

Figure 1. Operation Circuit Outline

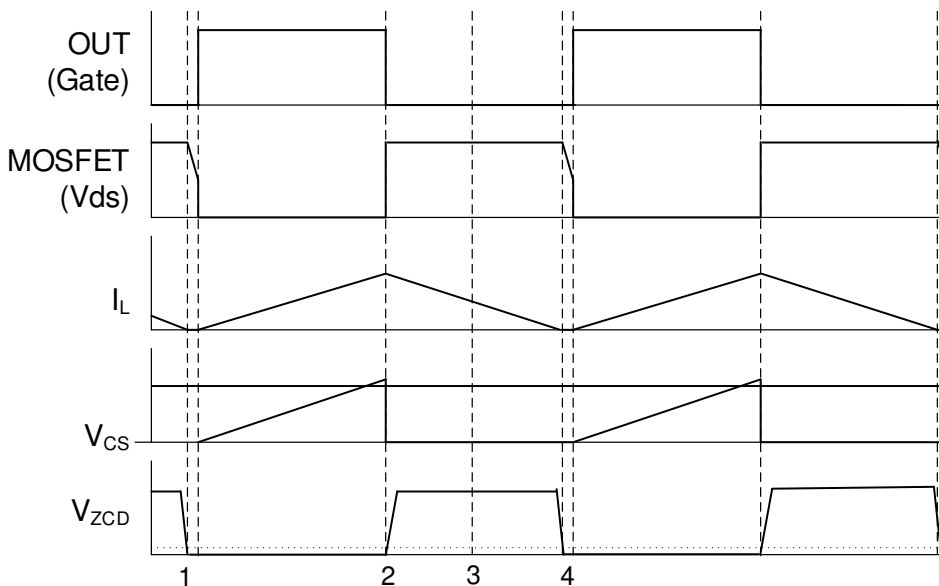

Figure 2. Switching Operation Timing Chart

Switching Operation

1. The MOSFET is turned on, and  $I_L$  increases.
2. The IC compares Multiplier out with  $V_{CS}$  slope, and the MOSFET is off when  $V_{CS}$  voltage is higher than Multiplier out.
3. The MOSFET is turned off, and  $I_L$  decreases.
4. The ZCD pin detects the zero point of the  $I_L$  and turns on the MOSFET.

Description of Blocks - continued

3 About ErrAMP

3.1 GmAMP

The VS pin monitors a divided point for resistance of the output voltage. The ripple voltage of the AC frequency (50 Hz / 60 Hz) overlaps with the VS pin. GmAMP removes this ripple voltage. GmAMP compares  $V_{AMP1}$  (2.500 V Typ) with the removed voltage, GmAMP controls the EO voltage by this gap. When the EO pin voltage rises, the ON width of the OUT pin becomes wide. Also, you must set the error amplifier constant so that the AC frequency does not overlap on the EO pin.

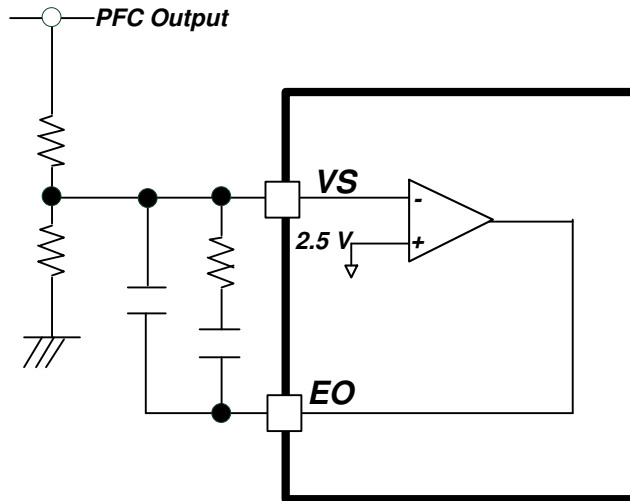

Figure 3. GmAMP Block Diagram

3.2 VS Short Protection

The VS pin has a short protection function.

When a state of the VS pin voltage  $< V_{SHORT}$  (0.3 V Typ) continues for  $t_{VS\_SH}$  (150  $\mu$ s Typ) or more, IC stops switching. Figure 4 shows the operation.

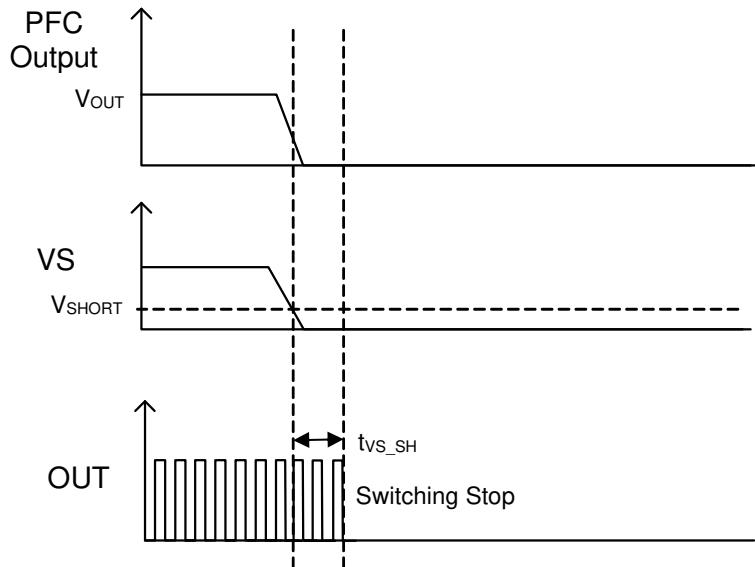

Figure 4. Operation of VS Short Protection

3 About ErrAMP - continued

3.3 Overvoltage Protection Function (IOVP)

When the PFC output voltage becomes overvoltage, it stops switching by a protection function. It shows below the setting method of the overvoltage protection voltage.

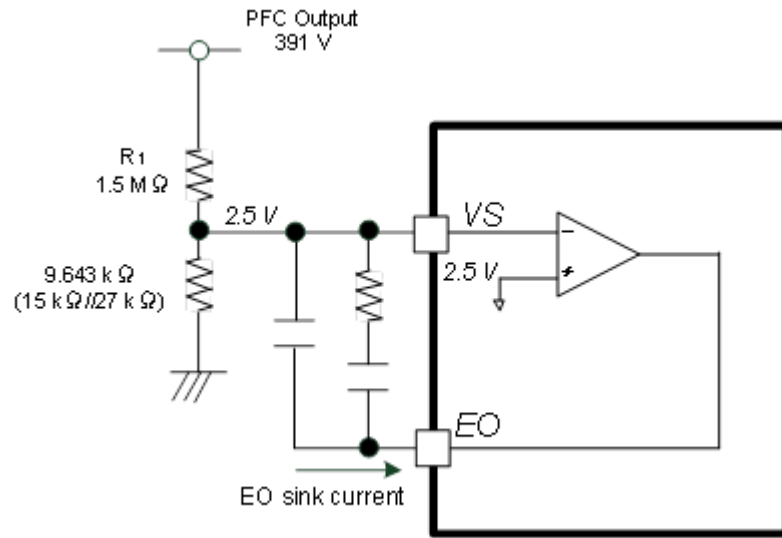

Figure 5. Overvoltage Protection Operation

When PFC output voltage exceeds 391 V, sink current flows in the EO pin. When this current grows to  $I_{OV\text{PDET}1}$  (27  $\mu\text{A Typ}$ ) or more, the IC stops switching and activates protection. In addition, the IC cancels protection when this current becomes or less  $I_{OV\text{PDET}2}$  (7  $\mu\text{A Typ}$ ).

The overvoltage protection detection voltage is  $I_{OV\text{PDET}1} \times R_1 + \text{PFCOUT voltage}$ .  $27 \mu\text{A} \times 1.5 \text{ M}\Omega + 391 \text{ V} = 431.5 \text{ V}$

The release voltage is  $I_{OV\text{PDET}2} \times R_1 + \text{PFCOUT voltage}$ .  $7 \mu\text{A} \times 1.5 \text{ M}\Omega + 391 \text{ V} = 401.5 \text{ V}$

When output voltage rises, the EO pin voltage falls down, too.

Description of Blocks - continued

4 ZCD Pin

The zero current detection circuit is a function to detect a zero cross of the inductor current ( $I_L$ ) (Figure 6, 7). If the voltage at the ZCD pin becomes lower than  $V_{ZCD2}$  (0.67 V Typ) after becoming higher than  $V_{ZCD1}$  (0.9 V Typ), the OUT output becomes High after the ZCD output delay time ( $t_{ZCD}$  260 ns Typ) has elapsed. When the ZCD voltage does not reach  $V_{ZCD1}$  (0.9 V Typ), it becomes the restart timer operation. After the OUT output becomes Low, OUT becomes High after  $t_{REST}$  (30  $\mu$ s Typ) progresses (Figure 8).

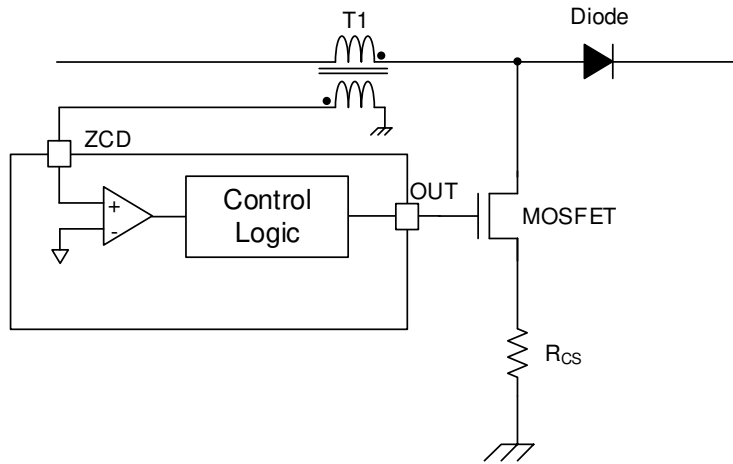

Figure 6. Zero Current Detection Circuit

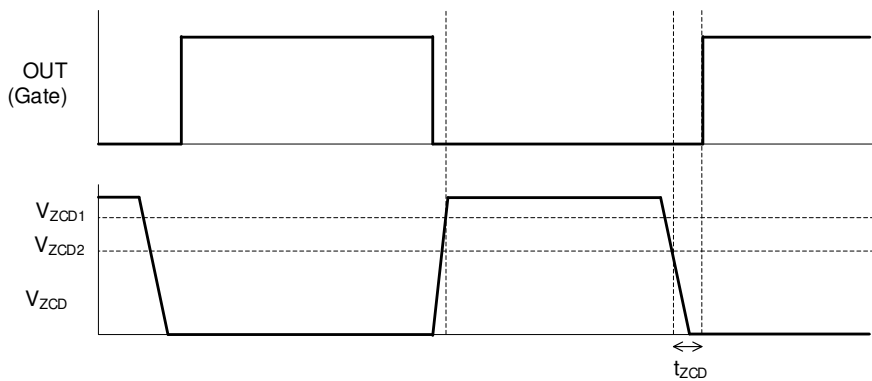

Figure 7. Zero Current Detection

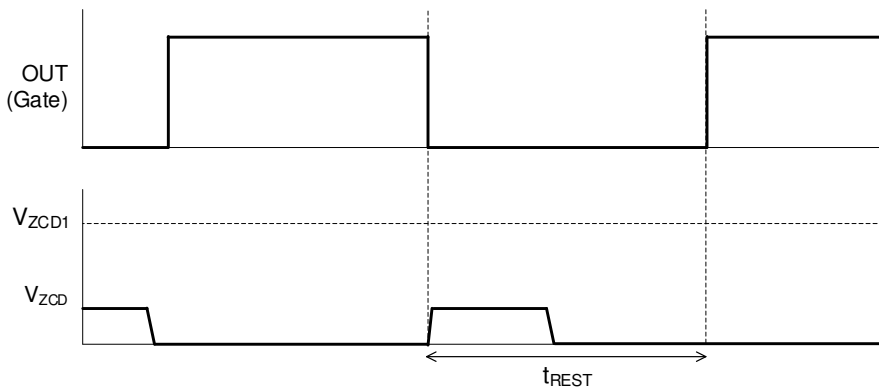

Figure 8. Restart Timer

Description of Blocks - continued

5 MULTIPLIER

The ON width of the OUT pin is fixed in Multiplier out and  $V_{CS}$  as shown in Figure 2.  
 The  $V_{CS}$  can be expressed in the following formula.

$$V_{CS} = K \times V_{MULT}(V_{EO} - 0.9 V)$$

- K: MULTIPLIER GAIN
- $V_{MULT}$ : MULT pin voltage
- $V_{EO}$ : EO pin voltage

AC voltage information is input into  $V_{MULT}$ . The IC improves the power factor by controlling AC current with the AC voltage. In addition,  $V_{CS}$  in AC voltage of 0 V ( $V_{MULT} = 0 V$ ) is expressed in the following formula.

$$V_{CS} = K \times V_{MULT}(V_{EO} - 0.9 V) + V_{OFFSET} = V_{OFFSET}$$

The ON width of the OUT pin at the age of AC voltage 0 V ( $V_{MULT} = 0 V$ ) becomes long by adding  $V_{OFFSET}$  (30 mV Typ). Because the ON width gets longer, the diode bridge output voltage is discharged. As a result, the AC current distortion is improved without the current supply from a diode bridge stopping (Figure 9).

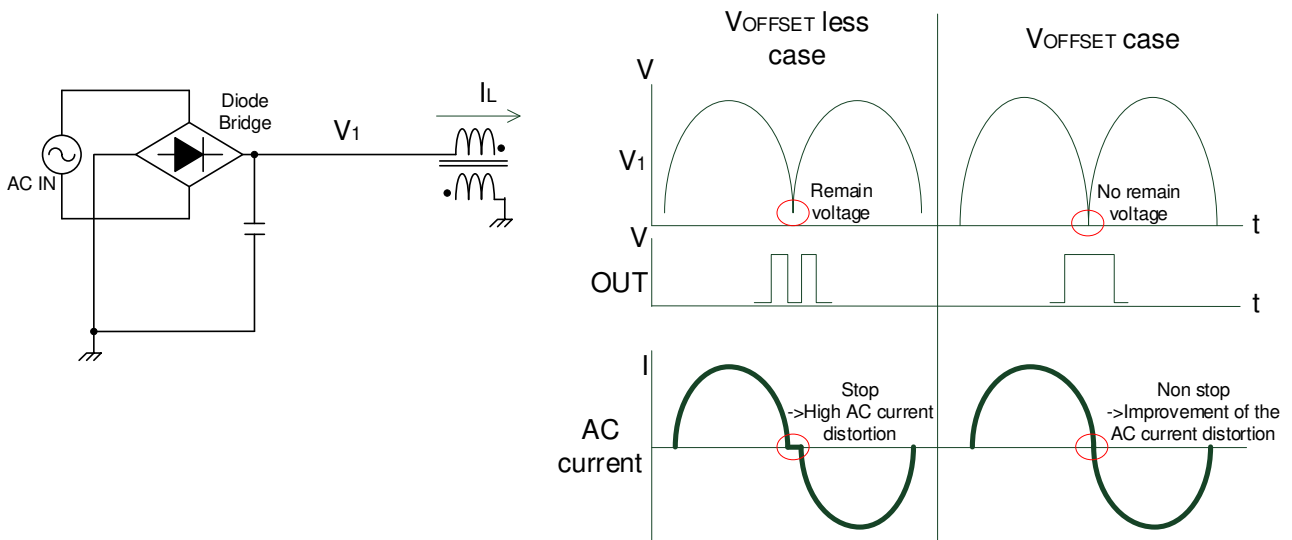

Figure 9. Improvement of the AC Current Distortion

Description of Blocks - continued

For light load conditions ( $EO < 0.85\text{ V}$ ), the gain of the Multiplier block is reduced by a quarter. Decreasing the gain will prevent early overvoltage protection at light load, which causes non-continuous switching operation. This function continues switching even at light load, as shown in Figure 11.

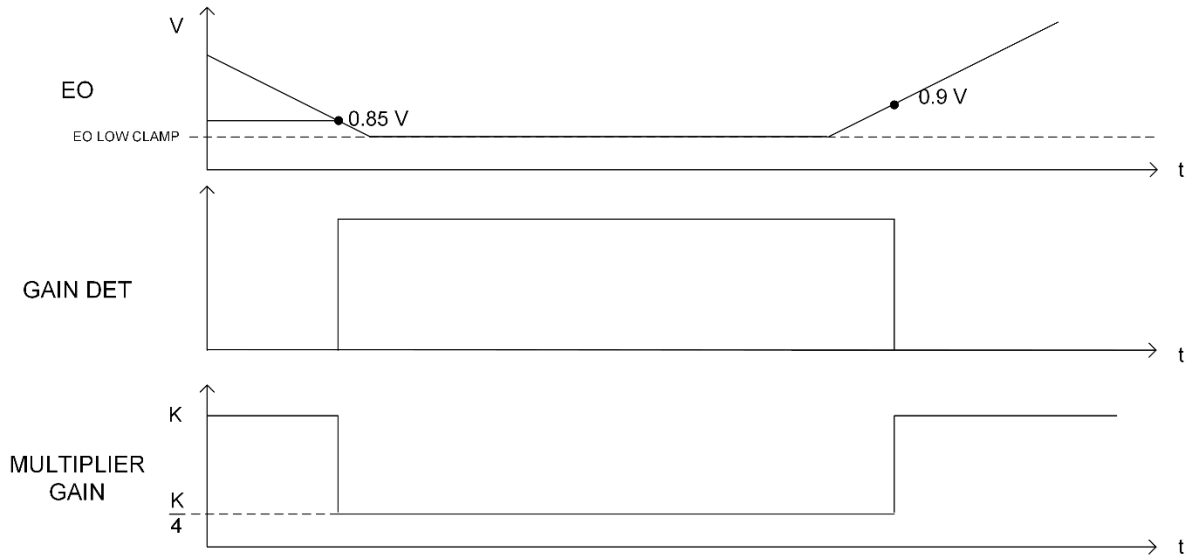

Figure 10. Multiplier Gain

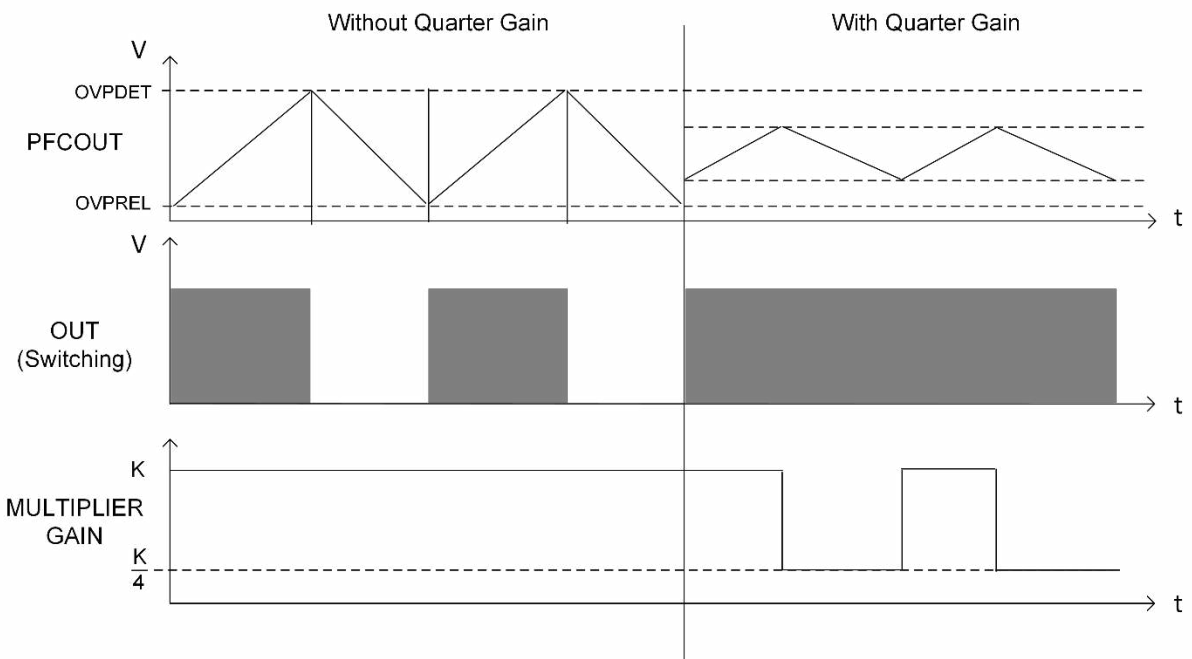

Figure 11. Improvement in Light Load Operation



Description of Blocks - continued

6 MULT Pin

When the state that the MULT pin voltage is lower than  $V_{BROUT1}$  (0.8 V Typ) continues for  $t_{BROUT}$  (160 ms Typ) or more, the IC stops switching by a brownout function (only in BD7696FJ). When the MULT pin voltage becomes higher than  $V_{BROUT2}$  (0.97 V Typ), the IC switches again.

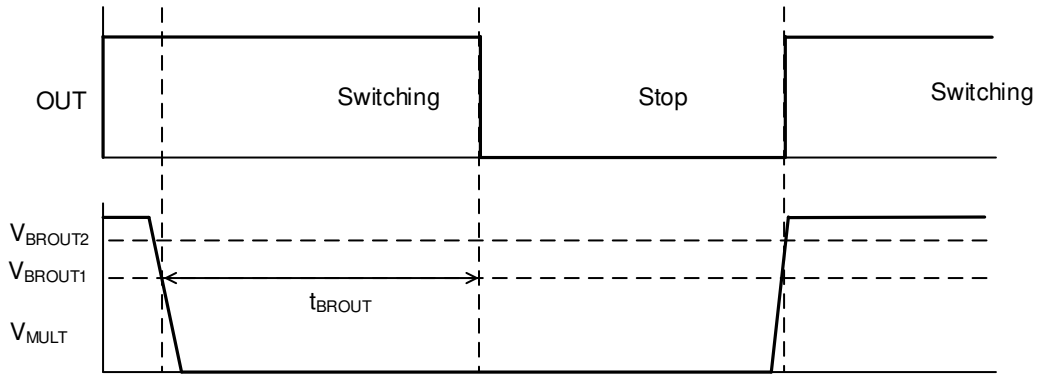

Figure 12. Brown Out

7 CS Pin

In normal operation, the turn-off decides by the ON width of the EO pin and the MULT pin voltage. However, the IC is off in a pulse by pulse overcurrent protection when the CS pin rises more than  $V_{CS}$  (1.08 V Typ). Through this protection, it prevents an overcurrent to the MOSFET. The overcurrent protection function limits the ON width. When this protection becomes the working PFC load, PFC output voltage decreases. You must decide sense resistance of PFC so that this protection does not work in rated load with the minimum input voltage at the time of the application design.

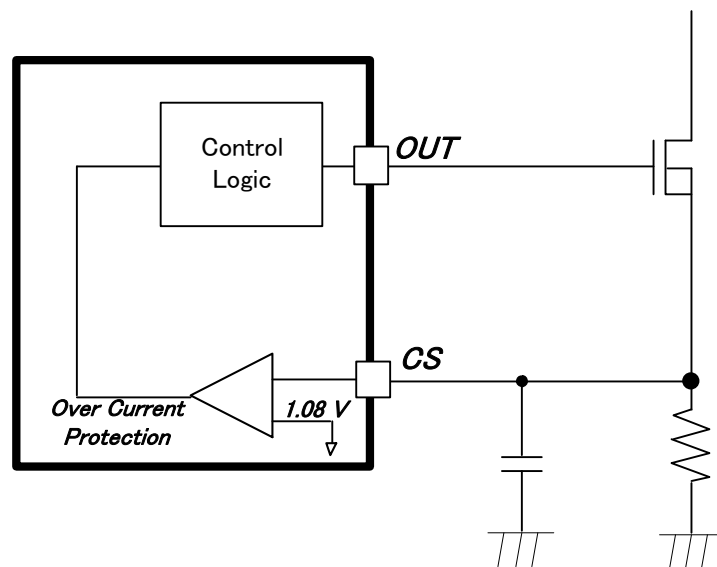

Figure 13. Current Limit

## Operation Mode of Protection Circuit

Table 1 showed the operation mode of each protection function.

Table 1. Operation Mode of Each Protective Circuit

Parameter	Contents	Protection Mode			
		Detection Method	Detection Operation	Cancellation Method	Cancellation Operation
VCC UVLO	Under Voltage Lock Out on the VCC pin	VCC < 10 V (Typ) (VCC fall)	OUT OFF EO discharge	VCC > 12.5 V (Typ) (VCC rise)	Startup Operation
CS OCP	Over Current Protection on the CS pin	CS > 1.08 V (Typ) (CS rise)	OUT OFF	CS < 1.08 V (Typ) (CS fall)	Normal Operation
VS Short Protection	Short Protection on the VS pin	VS < 0.3 V (Typ) (VS fall)	OUT OFF EO discharge	VS > 0.3 V (Typ) (VS rise)	Normal Operation
IOVP	Over Voltage Protection	EO > 27 $\mu$ A (Typ) (EO rise)	OUT OFF	EO < 7 $\mu$ A (Typ) (EO fall)	Normal Operation
Brown Out (Only BD7696FJ)	Low Voltage Protection on the MULT pin	MULT < 0.8 V (Typ) (MULT fall)	OUT OFF EO discharge	MULT > 0.97 V (Typ) (MULT rise)	Normal Operation

**Absolute Maximum Ratings (Ta = 25 °C)**

Parameter	Symbol	Rating	Unit	Condition
Maximum Voltage 1	V <sub>MAX1</sub>	-0.3 to +40	V	VCC
Maximum Voltage 2	V <sub>MAX2</sub>	-0.3 to +14	V	OUT
Maximum Voltage 3	V <sub>MAX3</sub>	-0.3 to +6.5	V	CS, MULT, VS, EO
Maximum Current	I <sub>ZCD</sub>	-10 to +10	mA	ZCD current
OUT Pin Output Peak Current 1	I <sub>OUT1</sub>	-0.5	A	Source current
OUT Pin Output Peak Current 2	I <sub>OUT2</sub>	+1	A	Sink current
Maximum Junction Temperature	T <sub>jmax</sub>	+150	°C	
Storage Temperature Range	T <sub>stg</sub>	-55 to +150	°C	

**Caution 1:** Operating the IC over the absolute maximum ratings may damage the IC. The damage can either be a short circuit between pins or an open circuit between pins and the internal circuitry. Therefore, it is important to consider circuit protection measures, such as adding a fuse, in case the IC is operated over the absolute maximum ratings.

**Caution 2:** Should by any chance the maximum junction temperature rating be exceeded the rise in temperature of the chip may result in deterioration of the properties of the chip. In case of exceeding this absolute maximum rating, design a PCB with thermal resistance taken into consideration by increasing board size and copper area so as not to exceed the maximum junction temperature rating.

**Thermal Resistance**(Note 1)

Parameter	Symbol	Thermal Resistance (Typ)		Unit
		1s <sup>(Note 3)</sup>	2s2p <sup>(Note 4)</sup>	
SOP-J8				
Junction to Ambient	θ <sub>JA</sub>	149.3	76.9	°C/W
Junction to Top Characterization Parameter <sup>(Note 2)</sup>	Ψ <sub>JT</sub>	18	11	°C/W

(Note 1) Based on JESD51-2A(Still-Air)

(Note 2) The thermal characterization parameter to report the difference between junction temperature and the temperature at the top center of the outside surface of the component package.

(Note 3) Using a PCB board based on JESD51-3.

(Note 4) Using a PCB board based on JESD51-7.

Layer Number of Measurement Board	Material	Board Size
Single	FR-4	114.3 mm x 76.2 mm x 1.57 mmt
Top		
Copper Pattern	Thickness	
Footprints and Traces	70 μm	

Layer Number of Measurement Board	Material	Board Size			
4 Layers	FR-4	114.3 mm x 76.2 mm x 1.6 mmt			
Top		2 Internal Layers		Bottom	
Copper Pattern	Thickness	Copper Pattern	Thickness	Copper Pattern	Thickness
Footprints and Traces	70 μm	74.2 mm x 74.2 mm	35 μm	74.2 mm x 74.2 mm	70 μm

**Recommended Operating Conditions**

Parameter	Symbol	Min	Typ	Max	Unit	Condition
Supply Voltage	VCC	12	15	38	V	VCC Voltage
Operating Temperature	Topr	-40	+25	+105	°C	

**Recommended Range of the External Component (Ta = 25 °C)**

Parameter	Symbol	Rating	Unit
VCC Pin Connection Capacity	C <sub>VCC</sub>	22 or more	μF

## Electrical Characteristics (Unless otherwise specified VCC = 15 V, Ta = -40 °C to +105 °C)

Parameter	Symbol	Min	Typ	Max	Unit	Condition
<b>[Circuit Current]</b>						
Circuit Current (ON) 1	I <sub>ON1</sub>	-	0.60	1.20	mA	VS = 0 V
Circuit Current (ON) 2	I <sub>ON2</sub>	-	0.95	2.00	mA	50 kHz switching
Circuit Current (ON) 3	I <sub>ON3</sub>	4.5	9.0	13.5	mA	VCC discharge Switching stop
Start Up Current	I <sub>START</sub>	-	60	110	μA	VCC = 11 V
<b>[VCC Pin Protection]</b>						
VCC UVLO Voltage1	V <sub>UVLO1</sub>	11.5	12.5	13.5	V	VCC rise
VCC UVLO Voltage2	V <sub>UVLO2</sub>	9	10	11	V	VCC fall
VCC UVLO Hysteresis	V <sub>UVLO3</sub>	2.0	2.5	3.0	V	V <sub>UVLO3</sub> = V <sub>UVLO1</sub> - V <sub>UVLO2</sub>
VCC Discharge Voltage1	V <sub>CC_DIS1</sub>	-	38	-	V	VCC rise
VCC Discharge Voltage2	V <sub>CC_DIS2</sub>	-	34	-	V	VCC fall
<b>[Gm Amplifier Block]</b>						
VS Pin Pull up Current	I <sub>VS</sub>	-	0.1	0.5	μA	VS = 0 V
Gm Amplifier Reference Voltage1	V <sub>AMP1</sub>	2.465	2.500	2.535	V	Ta = 25 °C
Gm Amplifier Reference Voltage2	V <sub>AMP2</sub>	2.44	-	2.54	V	Ta = -40 °C to +105 °C
Gm Amplifier Line Regulation	V <sub>AMP_LINE</sub>	-	1	10	mV	VCC = 10 V to 38 V
Gm Amplifier Source Current	I <sub>EO_SOURCE</sub>	50	130	200	μA	VS = 2.3 V
Gm Amplifier Sink Current	I <sub>EO_SINK</sub>	50	130	200	μA	VS = 2.7 V
<b>[EO Block]</b>						
EO Low Voltage	V <sub>EOL</sub>	-	0.4	0.8	V	VS = 2.7 V
Quarter Gain Detect Voltage1	V <sub>QGAIN1</sub>	0.80	0.85	-	V	MULT = 50 mV, CS = 20 mV
Quarter Gain Detect Voltage2	V <sub>QGAIN2</sub>	-	0.90	0.95	V	MULT = 50 mV, CS = 20 mV
EO Discharge Current	I <sub>EO</sub>	0.8	1.8	3.0	mA	VCC = 12 V, EO = 1.0 V
<b>[MULT Block]</b>						
MULT Pin Pull up Current	I <sub>MULT</sub>	-	0.1	0.5	μA	MULT = 0 V
MULT Pin Dynamic Range	V <sub>MULT</sub>	0 to 2.5	0 to 3.5	-	V	
EO Pin Dynamic Range	V <sub>EOD</sub>	0.9 to 2.9	0.9 to 3.4	-	V	
MULTIPLIER Gain	K	0.33	0.42	0.51	1/V	MULT = 1 V, EO = 2.5 V
MULTIPLIER Quarter Gain	K/4	-	0.11	-	1/V	MULT = 1 V, EO = 0.8 V
Brown Out Detect Voltage1	V <sub>BROUT1</sub>	0.7	0.8	0.9	V	MULT fall BD7696FJ Only
Brown Out Detect Voltage2	V <sub>BROUT2</sub>	0.87	0.97	1.07	V	MULT rise BD7696FJ Only
Brown Out Detect Timer	t <sub>BROUT</sub>	80	160	320	ms	BD7696FJ Only
<b>[ZCD Block]</b>						
ZCD Threshold Voltage1	V <sub>ZCD1</sub>	0.8	0.9	1.0	V	ZCD rise
ZCD Threshold Voltage2	V <sub>ZCD2</sub>	0.55	0.67	0.79	V	ZCD fall
ZCD Output Delay	t <sub>ZCD</sub>	-	260	520	ns	
Input H Clamp Voltage	V <sub>IH</sub>	6.1	6.7	-	V	I <sub>sink</sub> = 3 mA
Input L Clamp Voltage	V <sub>IL</sub>	-0.3	-0.1	-	V	I <sub>source</sub> = -3 mA
Restart Timer	t <sub>REST</sub>	15	30	45	μs	
<b>[Protection Block]</b>						
VS Short Protection Detection Voltage	V <sub>SHORT</sub>	0.2	0.3	0.4	V	
VS Shortstop Protection Detection Time	t <sub>VS_SH</sub>	50	150	300	μs	
IOVP Detection Current 1	I <sub>OVDET1</sub>	19.5	27.0	30.5	μA	I <sub>EO_SINK</sub> rise Ta = 25 °C
IOVP Detection Current 2	I <sub>OVDET2</sub>	-	7	-	μA	I <sub>EO_SINK</sub> fall Ta = 25 °C

## Electrical Characteristics (Unless otherwise specified VCC = 15 V, Ta = -40 °C to +105 °C) - continued

Parameter	Symbol	Min	Typ	Max	Unit	Condition
<b>[CS Block]</b>						
CS Threshold Voltage	V <sub>CS</sub>	1.00	1.08	1.16	V	
Output Delay Time	t <sub>DELAY</sub>	-	150	300	ns	
CS Pin Pull up Current	I <sub>CS</sub>	-	0.15	1.00	μA	CS = 0 V
CS Offset Voltage	V <sub>OFFSET</sub>	-	30	-	mV	MULT = 0 V
<b>[OUT Block]</b>						
OUT H Voltage	V <sub>POUTH</sub>	9.0	10.2	11.4	V	OUT = -20 mA
OUT L Voltage	V <sub>POUTL</sub>	-	-	0.8	V	OUT = +20 mA
Rise Time	t <sub>r</sub>	-	50	-	ns	OUT load capacitor = 1000 pF OUTL Voltage to 5 V
Fall Time	t <sub>f</sub>	-	50	-	ns	OUT load capacitor = 1000 pF OUTH Voltage to 5 V
OUT Pull down Resistance	R <sub>PDOUT</sub>	50	100	150	kΩ	

Typical Performance Curves

(Reference data)

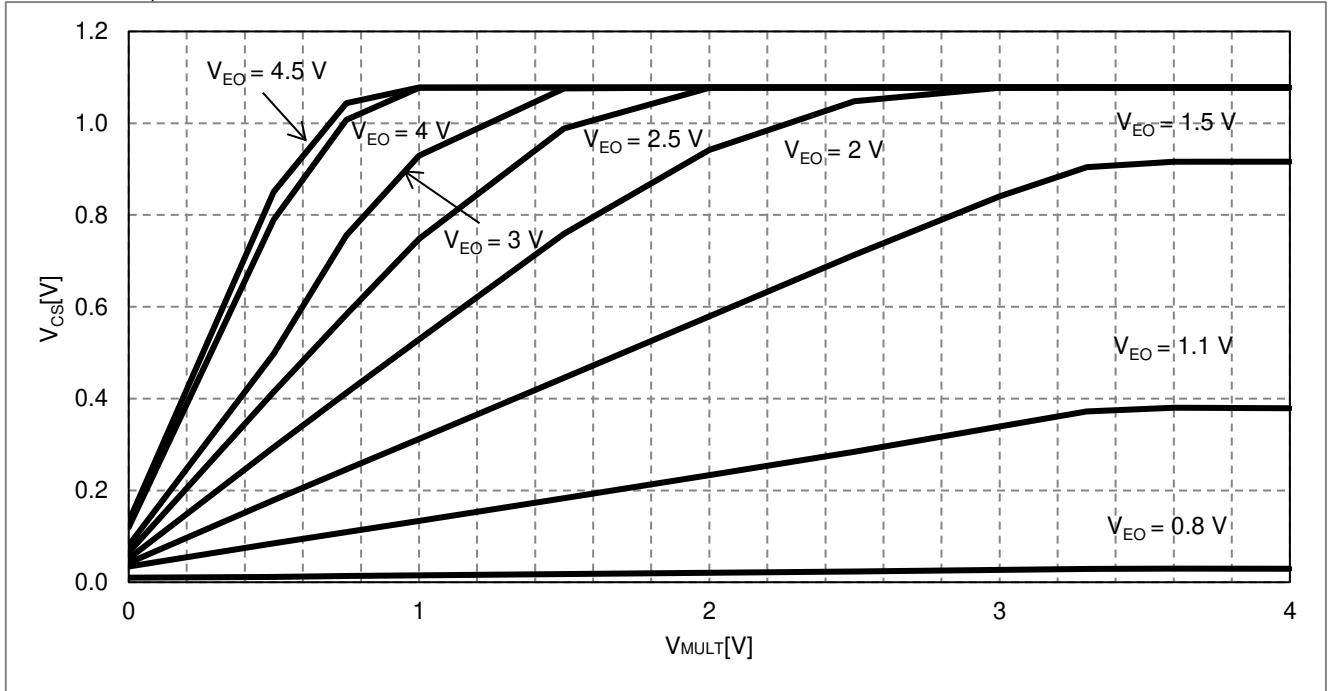

Figure 14.  $V_{CS}$  vs  $V_{MULT}$

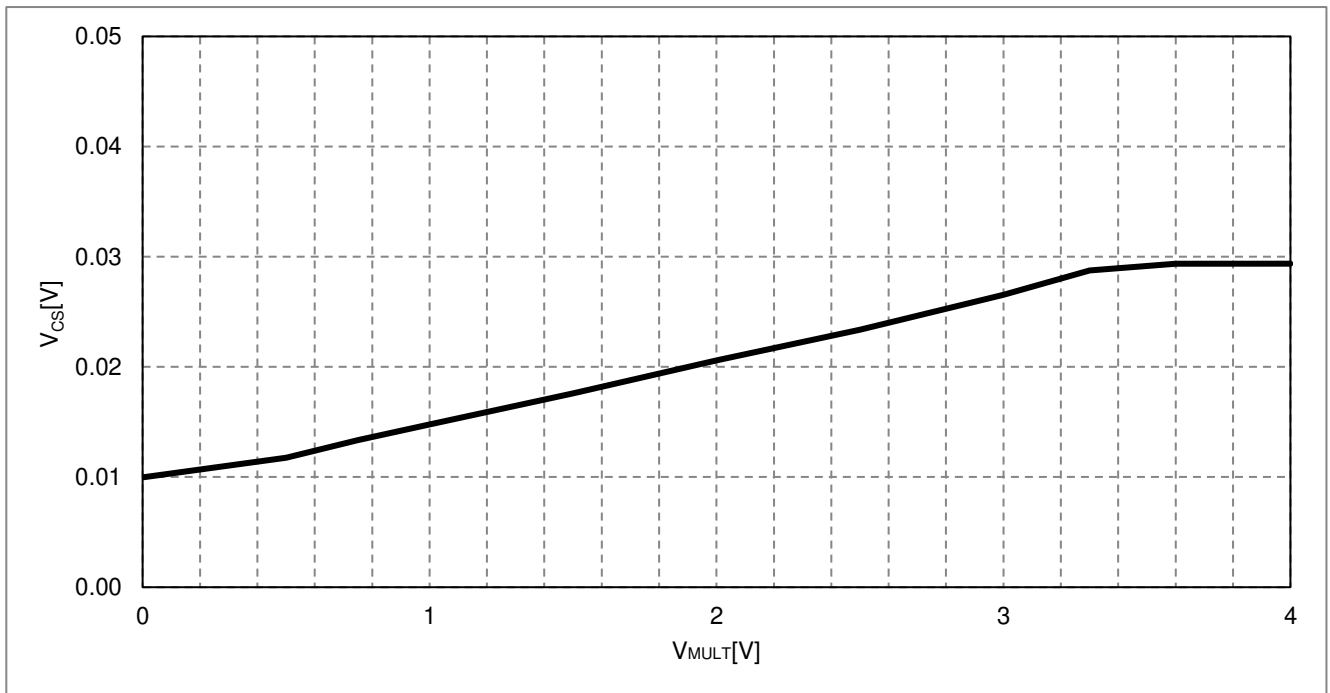

Figure 15.  $V_{CS}$  vs  $V_{MULT}$  at Quarter Gain Operation

Typical Performance Curves – continued

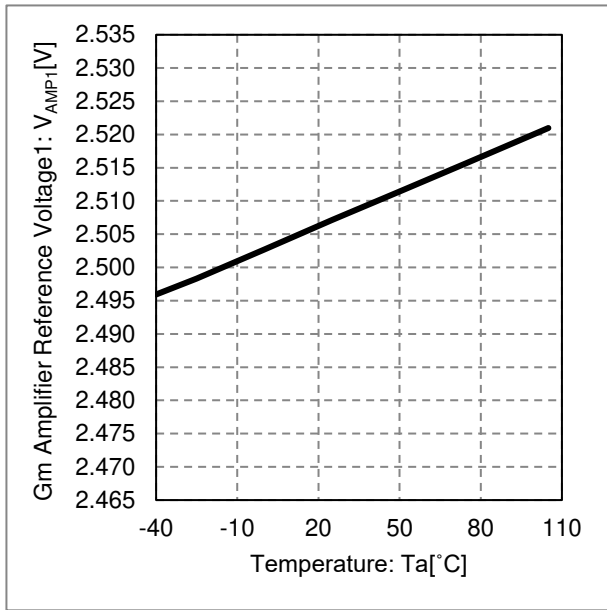

Figure 16. Gm Amplifier Reference Voltage1 vs Temperature

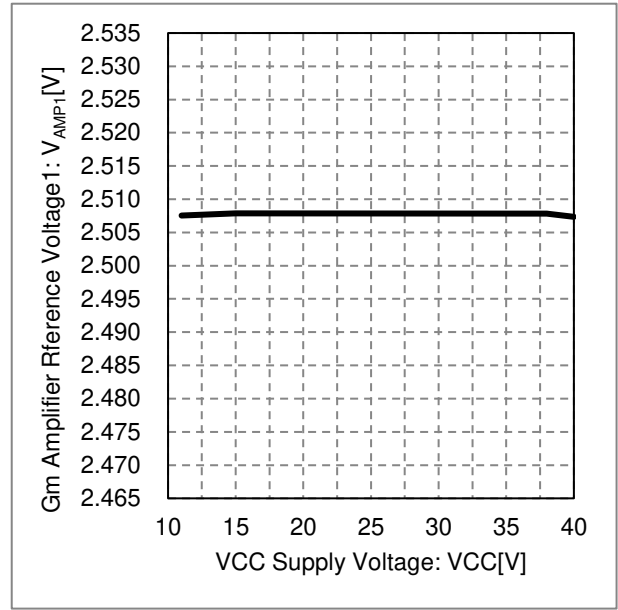

Figure 17. Gm Amplifier Reference Voltage1 vs VCC

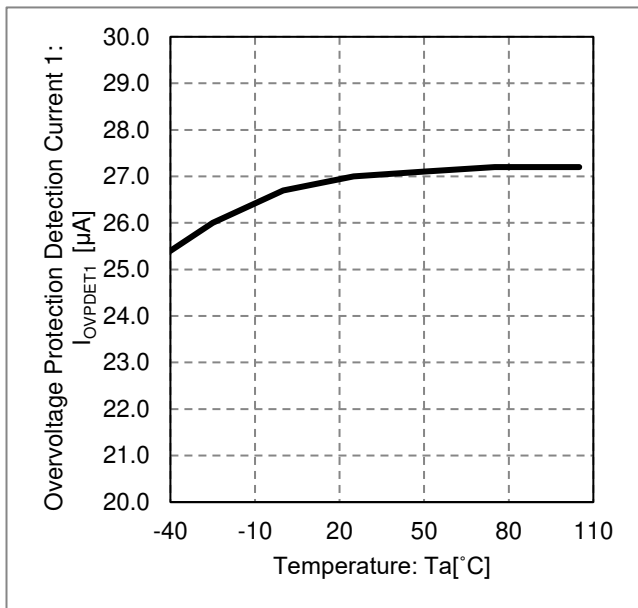

Figure 18. Overvoltage Protection Detection Current 1 vs Temperature

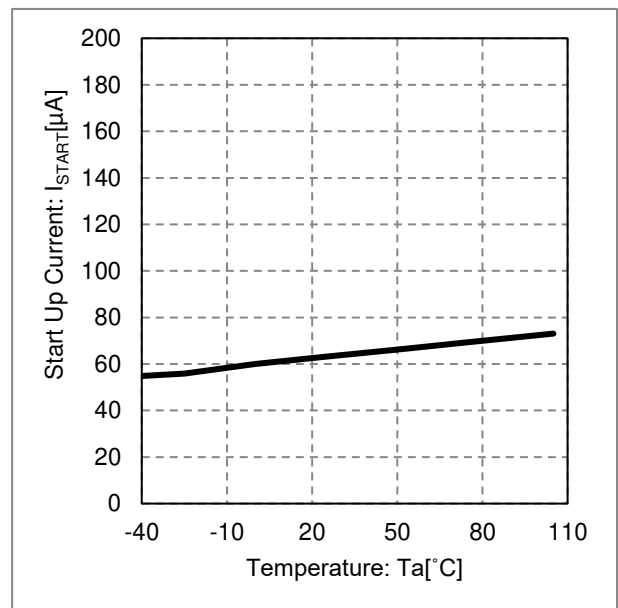

Figure 19. Start Up Current vs Temperature

Typical Performance Curves – continued

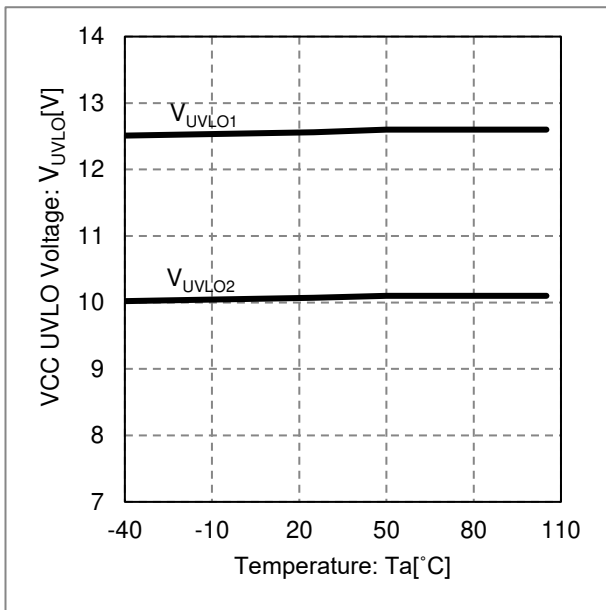

Figure 20. VCC UVLO Voltage vs Temperature

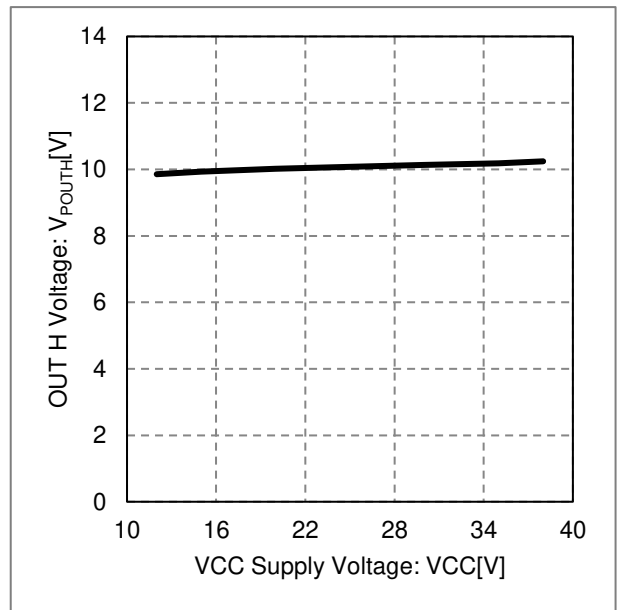

Figure 21. OUT H Voltage vs VCC

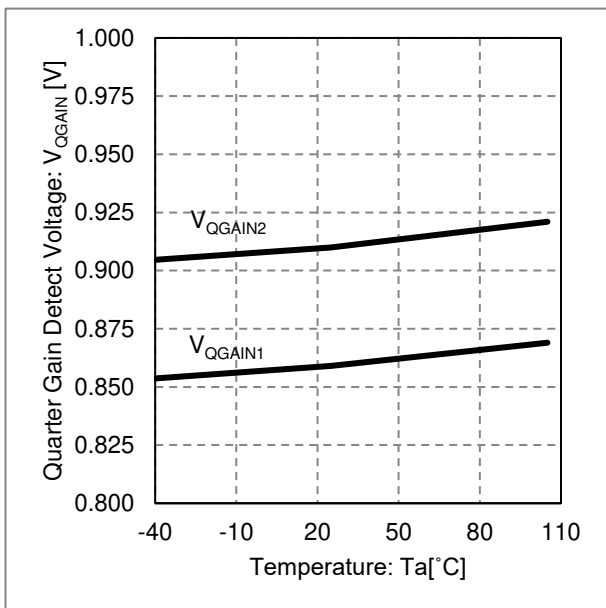

Figure 22. Quarter Gain Detect Voltage vs Temperature



## Application Example

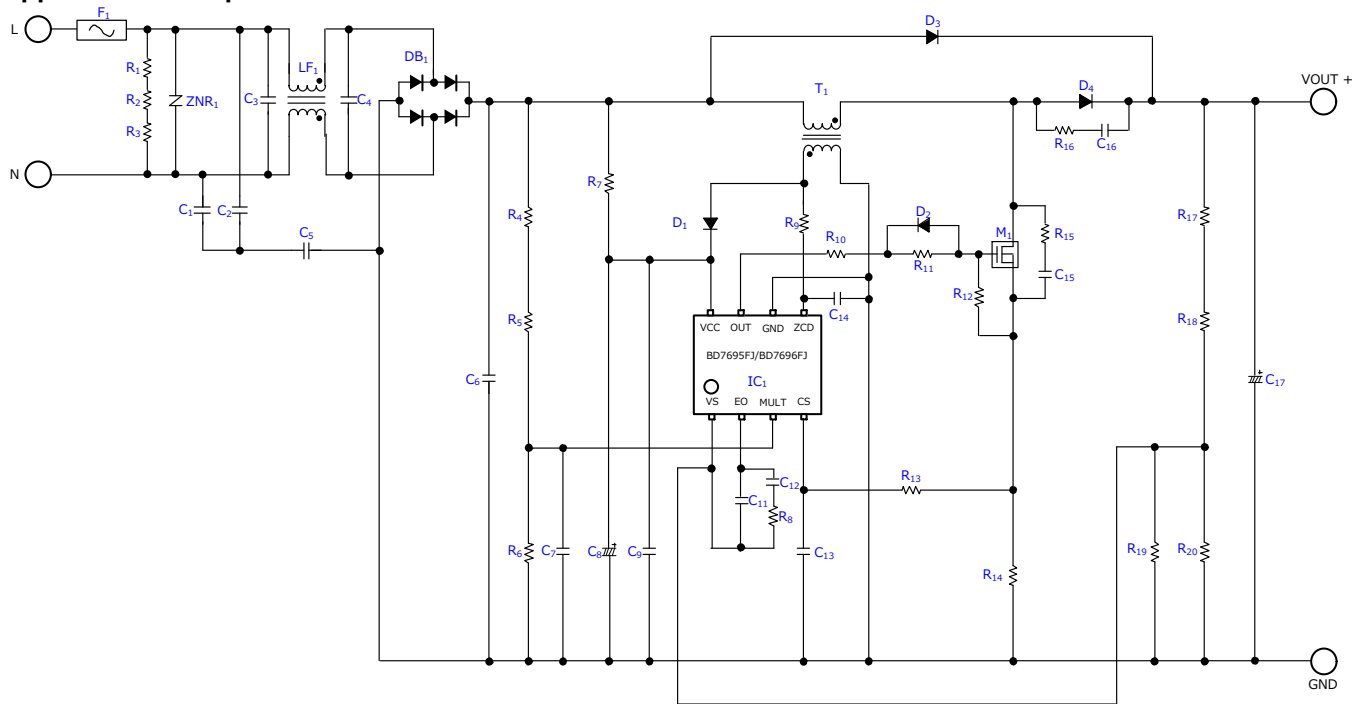

Figure 23. Application Example

### 1 Output Voltage Setting

The output voltage is decided on feedback resistance by the VS pin.

$$V_{OUT} = \left(1 + \frac{(R_{17} + R_{18})}{(R_{19} // R_{20})}\right) \times V_{AMP} = \left(1 + \frac{1582 \text{ k}\Omega}{10 \text{ k}\Omega}\right) \times 2.5 \text{ V} = 398 \text{ [V]}$$

$R_{17} + R_{18}$ : Upper side resistor of the output feedback  
 $R_{19} // R_{20}$ : Bottom side resistor of the output feedback  
 $V_{AMP}$ : Gm amplifier reference voltage1

### 2 Calculation of the Inductance

Reference value in case of  $V_{OUT} = 400 \text{ V}$ , Output power = 200 W

$$L = 250 \text{ [\mu H]}$$

Setting a large value of inductance will reduce the THD but increase the component size.

### 3 External Parts of VCC

The VCC pin can reduce the VCC voltage change at the time of the switching by attaching a capacitor.

The VCC capacitor recommends electric field capacitor of 22  $\mu\text{F}$  or more withstand pressure of 50 V or more.

In addition, you must confirm the VCC voltage evaluation at the time of startup and the protection detection with an actual board when VCC is generated by startup resistance and the auxiliary winding of the transformer.

Because the consumption current of the IC decreases when an IC becomes the switching stop state after startup, the VCC voltage may rise by startup resistance. The overvoltage destruction of VCC is prevented by VCC voltage discharge function. The startup resistor value is made small by this function, so boot-time becomes fast.

**Attention in the Board Design**

About parts placement

You must locate the parts in the Figure 24 inside dot line near the IC. In addition, it is necessary to parts placement to avoid the interference with switching lines and high current lines such as inductor, DRAIN.

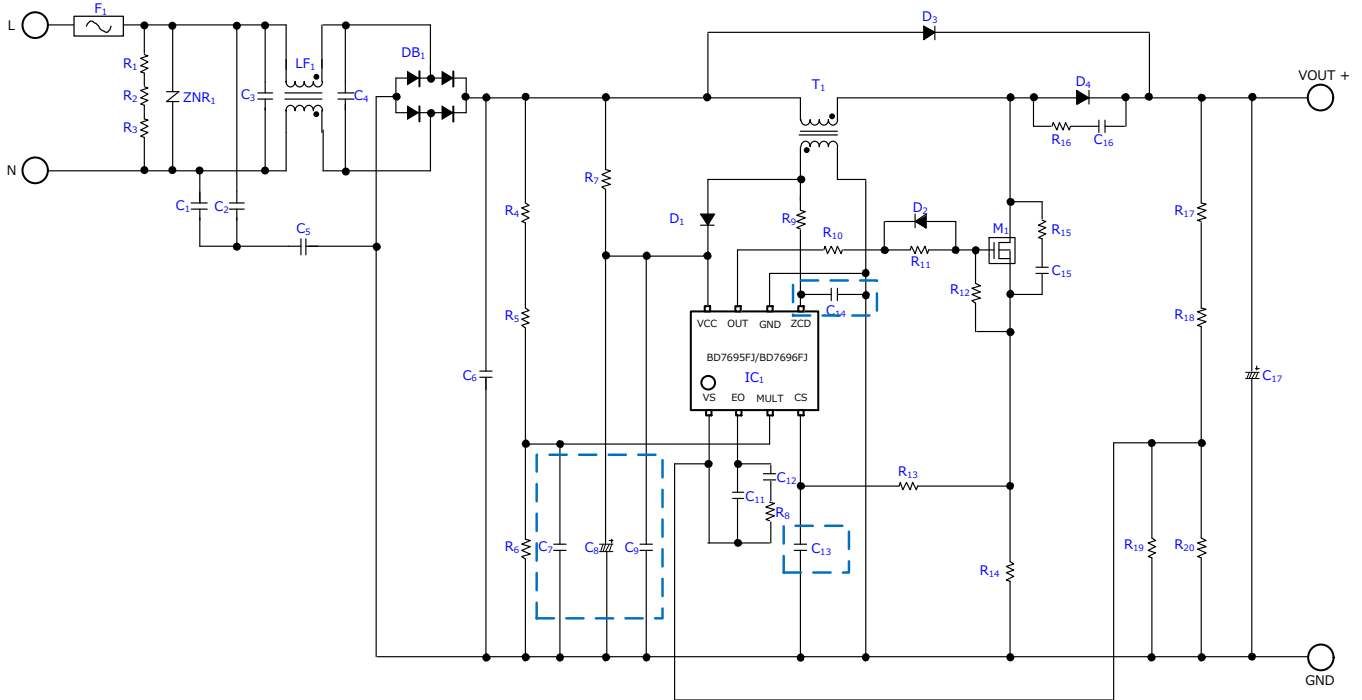

Figure 24. Parts Placement

About GND wiring guidance

The red line in Figure 25 is the GND lines which large current flows. Draw each line as an independent wire. In addition, pull the wiring thick and short. The blue line is the GND of the IC. Make the GND of the IC and the GND of the peripheral parts common.

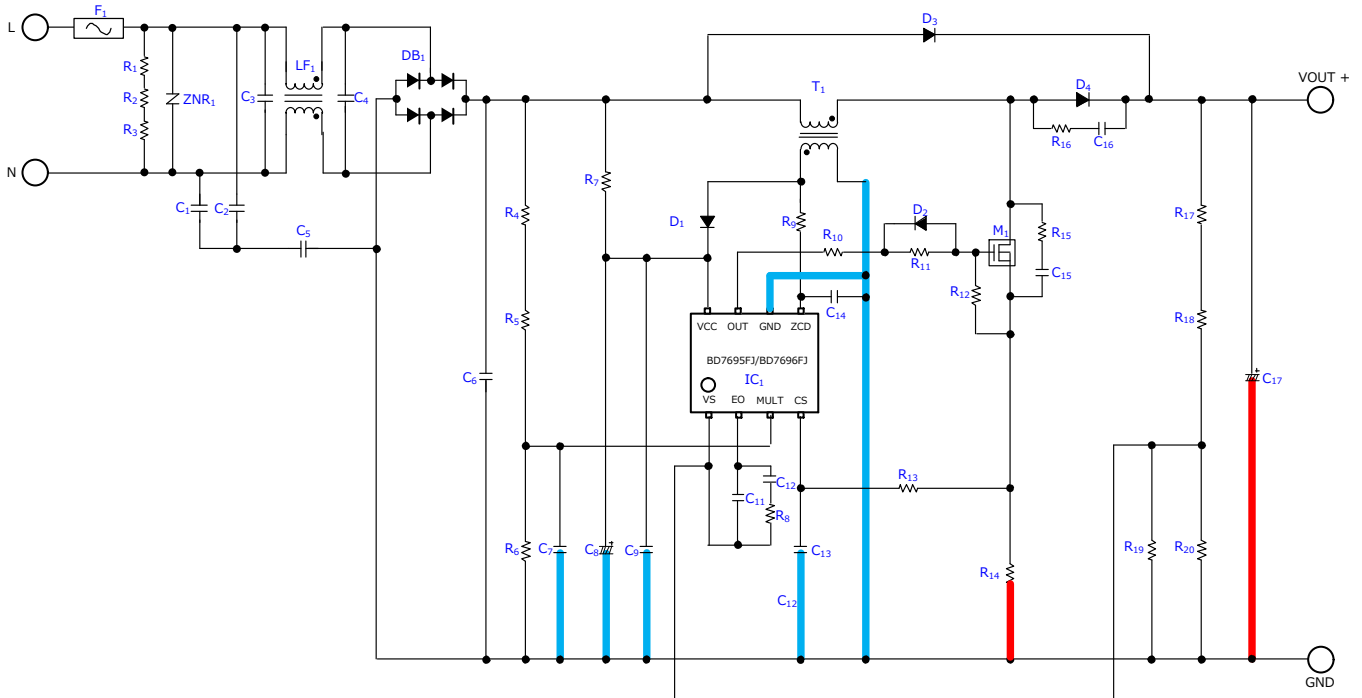

Figure 25. GND Line Layout

Attention in the Board Design – continued

About a large current line

Large circuit current flows through the part of the red line in Figure 26. You must wire it short and thickly. Do not place the IC and high impedance line near the red line because it has large noise.

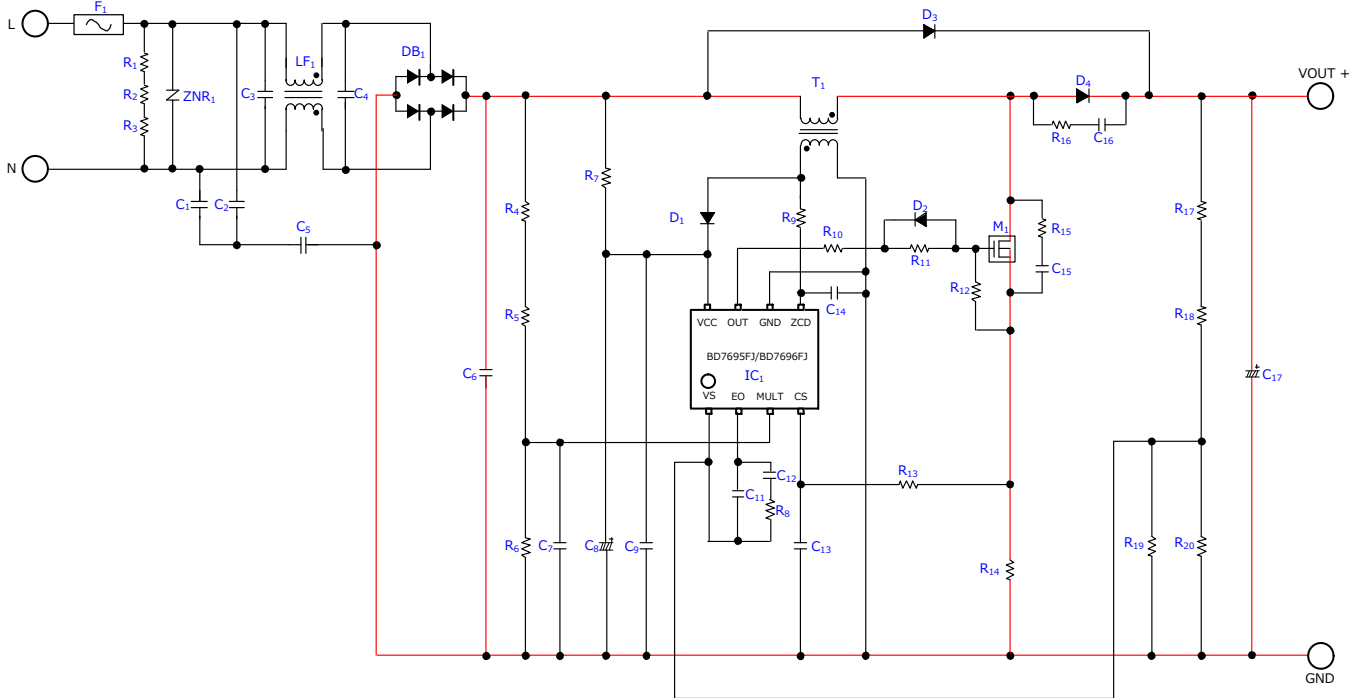

Figure 26. High Current Line Layout

I/O Equivalence Circuits

1	VS	2	EO	3	MULT	4	CS
5	ZCD	6	GND	7	OUT	8	VCC

## Operational Notes

### 1. Reverse Connection of Power Supply

Connecting the power supply in reverse polarity can damage the IC. Take precautions against reverse polarity when connecting the power supply, such as mounting an external diode between the power supply and the IC's power supply pins.

### 2. Power Supply Lines

Design the PCB layout pattern to provide low impedance supply lines. Furthermore, connect a capacitor to ground at all power supply pins. Consider the effect of temperature and aging on the capacitance value when using electrolytic capacitors.

### 3. Ground Voltage

Except for pins the output and the input of which were designed to go below ground, ensure that no pins are at a voltage below that of the ground pin at any time, even during transient condition.

### 4. Ground Wiring Pattern

When using both small-signal and large-current ground traces, the two ground traces should be routed separately but connected to a single ground at the reference point of the application board to avoid fluctuations in the small-signal ground caused by large currents. Also ensure that the ground traces of external components do not cause variations on the ground voltage. The ground lines must be as short and thick as possible to reduce line impedance.

### 5. Recommended Operating Conditions

The function and operation of the IC are guaranteed within the range specified by the recommended operating conditions. The characteristic values are guaranteed only under the conditions of each item specified by the electrical characteristics.

### 6. Inrush Current

When power is first supplied to the IC, it is possible that the internal logic may be unstable and inrush current may flow instantaneously due to the internal powering sequence and delays, especially if the IC has more than one power supply. Therefore, give special consideration to power coupling capacitance, power wiring, width of ground wiring, and routing of connections.

### 7. Testing on Application Boards

When testing the IC on an application board, connecting a capacitor directly to a low-impedance output pin may subject the IC to stress. Always discharge capacitors completely after each process or step. The IC's power supply should always be turned off completely before connecting or removing it from the test setup during the inspection process. To prevent damage from static discharge, ground the IC during assembly and use similar precautions during transport and storage.

### 8. Inter-pin Short and Mounting Errors

Ensure that the direction and position are correct when mounting the IC on the PCB. Incorrect mounting may result in damaging the IC. Avoid nearby pins being shorted to each other especially to ground, power supply and output pin. Inter-pin shorts could be due to many reasons such as metal particles, water droplets (in very humid environment) and unintentional solder bridge deposited in between pins during assembly to name a few.

### 9. Unused Input Pins

Input pins of an IC are often connected to the gate of a MOS transistor. The gate has extremely high impedance and extremely low capacitance. If left unconnected, the electric field from the outside can easily charge it. The small charge acquired in this way is enough to produce a significant effect on the conduction through the transistor and cause unexpected operation of the IC. So unless otherwise specified, unused input pins should be connected to the power supply or ground line.

## Operational Notes – continued

## 10. Regarding the Input Pin of the IC

This monolithic IC contains P+ isolation and P substrate layers between adjacent elements in order to keep them isolated. P-N junctions are formed at the intersection of the P layers with the N layers of other elements, creating a parasitic diode or transistor. For example (refer to figure below):

When  $GND > Pin A$  and  $GND > Pin B$ , the P-N junction operates as a parasitic diode.

When  $GND > Pin B$ , the P-N junction operates as a parasitic transistor.

Parasitic diodes inevitably occur in the structure of the IC. The operation of parasitic diodes can result in mutual interference among circuits, operational faults, or physical damage. Therefore, conditions that cause these diodes to operate, such as applying a voltage lower than the GND voltage to an input pin (and thus to the P substrate) should be avoided.

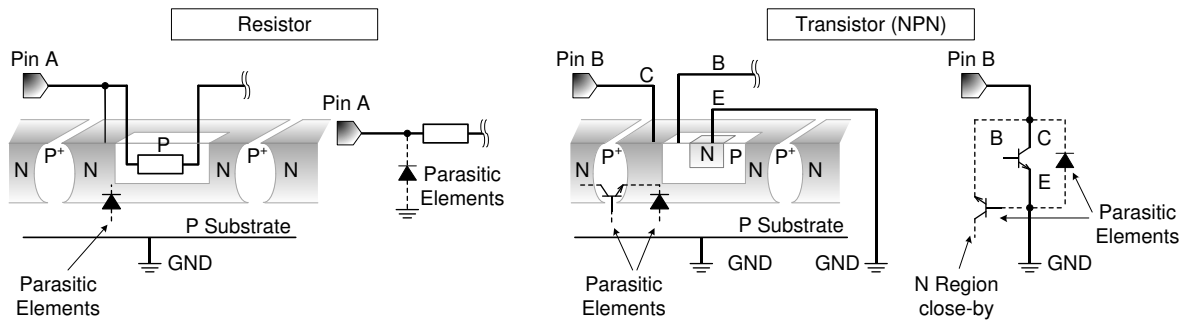

Figure 27. Example of Monolithic IC Structure

## 11. Ceramic Capacitor

When using a ceramic capacitor, determine a capacitance value considering the change of capacitance with temperature and the decrease in nominal capacitance due to DC bias and others.

## 12. Thermal Shutdown Circuit (TSD)

This IC has a built-in thermal shutdown circuit that prevents heat damage to the IC. Normal operation should always be within the IC's maximum junction temperature rating. If however the rating is exceeded for a continued period, the junction temperature ( $T_j$ ) will rise which will activate the TSD circuit that will turn OFF power output pins. When the  $T_j$  falls below the TSD threshold, the circuits are automatically restored to normal operation.

Note that the TSD circuit operates in a situation that exceeds the absolute maximum ratings and therefore, under no circumstances, should the TSD circuit be used in a set design or for any purpose other than protecting the IC from heat damage.

## 13. Over Current Protection Circuit (OCP)

This IC incorporates an integrated overcurrent protection circuit that is activated when the load is shorted. This protection circuit is effective in preventing damage due to sudden and unexpected incidents. However, the IC should not be used in applications characterized by continuous operation or transitioning of the protection circuit.

Ordering Information

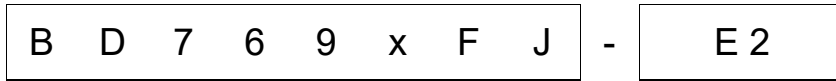

x: Brown out Package  
 5: None- FJ: SOP-J8  
 6: With

Packaging and forming specification  
 E2: Embossed tape and reel

Marking Diagram

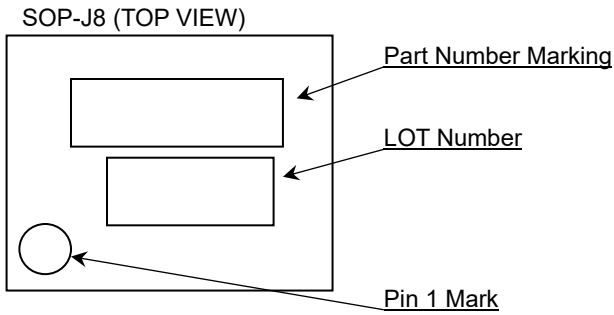

Part Number Marking	Product name
D7695	BD7695FJ-E2
D7696	BD7696FJ-E2

Physical Dimension and Packing Information

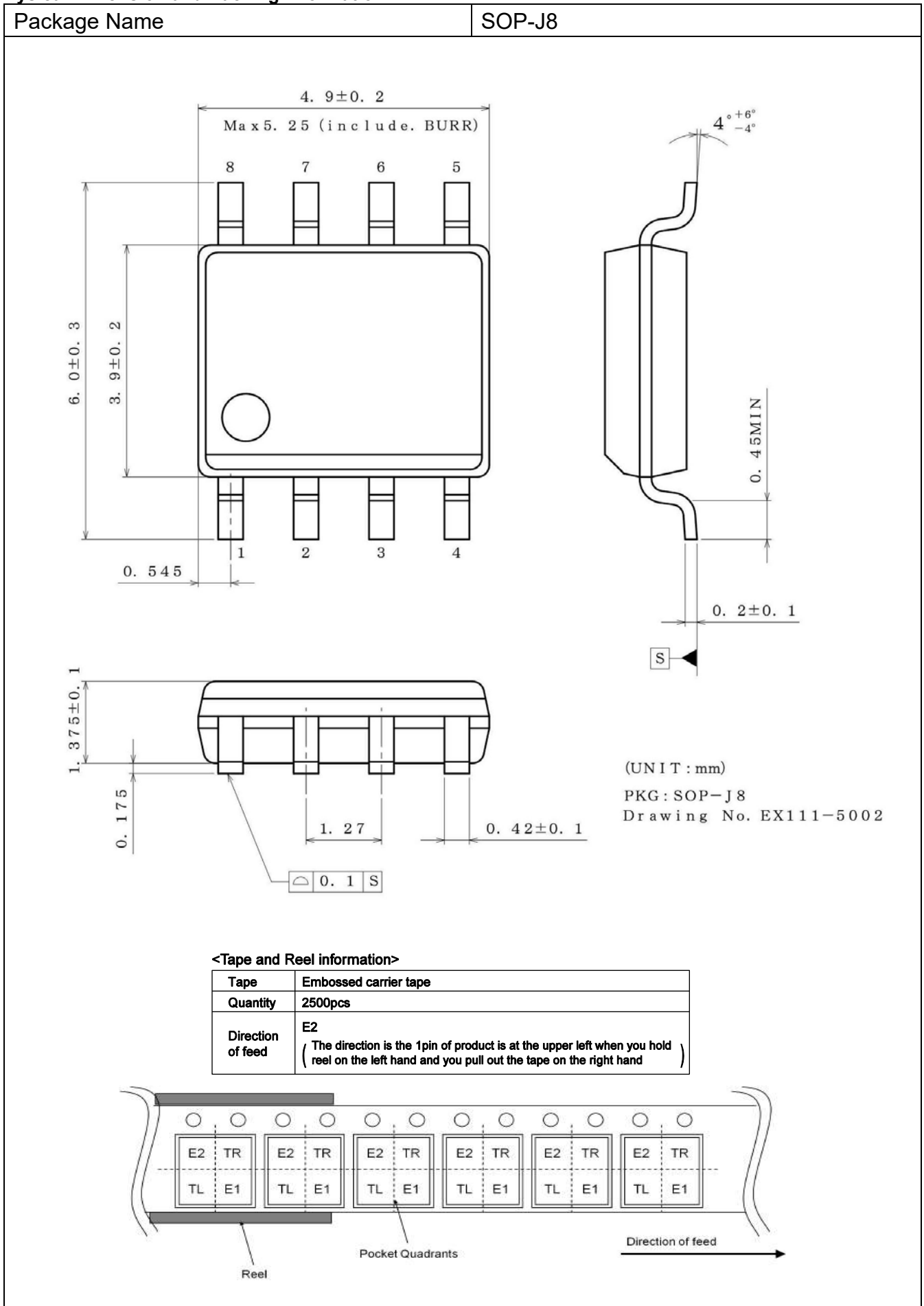

**Revision History**

Date	Revision	Changes
15.Jul.2022	001	New Release



# Notice

## Precaution on using ROHM Products

- Our Products are designed and manufactured for application in ordinary electronic equipment (such as AV equipment, OA equipment, telecommunication equipment, home electronic appliances, amusement equipment, etc.). If you intend to use our Products in devices requiring extremely high reliability (such as medical equipment <sup>(Note 1)</sup>, transport equipment, traffic equipment, aircraft/spacecraft, nuclear power controllers, fuel controllers, car equipment including car accessories, safety devices, etc.) and whose malfunction or failure may cause loss of human life, bodily injury or serious damage to property ("Specific Applications"), please consult with the ROHM sales representative in advance. Unless otherwise agreed in writing by ROHM in advance, ROHM shall not be in any way responsible or liable for any damages, expenses or losses incurred by you or third parties arising from the use of any ROHM's Products for Specific Applications.

(Note1) Medical Equipment Classification of the Specific Applications

JAPAN	USA	EU	CHINA
CLASS III	CLASS III	CLASS II b	CLASS III
CLASS IV		CLASS III	

- ROHM designs and manufactures its Products subject to strict quality control system. However, semiconductor products can fail or malfunction at a certain rate. Please be sure to implement, at your own responsibilities, adequate safety measures including but not limited to fail-safe design against the physical injury, damage to any property, which a failure or malfunction of our Products may cause. The following are examples of safety measures:
  - Installation of protection circuits or other protective devices to improve system safety
  - Installation of redundant circuits to reduce the impact of single or multiple circuit failure
- Our Products are designed and manufactured for use under standard conditions and not under any special or extraordinary environments or conditions, as exemplified below. Accordingly, ROHM shall not be in any way responsible or liable for any damages, expenses or losses arising from the use of any ROHM's Products under any special or extraordinary environments or conditions. If you intend to use our Products under any special or extraordinary environments or conditions (as exemplified below), your independent verification and confirmation of product performance, reliability, etc. prior to use, must be necessary:
  - Use of our Products in any types of liquid, including water, oils, chemicals, and organic solvents
  - Use of our Products outdoors or in places where the Products are exposed to direct sunlight or dust
  - Use of our Products in places where the Products are exposed to sea wind or corrosive gases, including Cl<sub>2</sub>, H<sub>2</sub>S, NH<sub>3</sub>, SO<sub>2</sub>, and NO<sub>2</sub>
  - Use of our Products in places where the Products are exposed to static electricity or electromagnetic waves
  - Use of our Products in proximity to heat-producing components, plastic cords, or other flammable items
  - Sealing or coating our Products with resin or other coating materials
  - Use of our Products without cleaning residue of flux (Exclude cases where no-clean type fluxes is used. However, recommend sufficiently about the residue.) ; or Washing our Products by using water or water-soluble cleaning agents for cleaning residue after soldering
  - Use of the Products in places subject to dew condensation
- The Products are not subject to radiation-proof design.
- Please verify and confirm characteristics of the final or mounted products in using the Products.
- In particular, if a transient load (a large amount of load applied in a short period of time, such as pulse, is applied, confirmation of performance characteristics after on-board mounting is strongly recommended. Avoid applying power exceeding normal rated power; exceeding the power rating under steady-state loading condition may negatively affect product performance and reliability.
- De-rate Power Dissipation depending on ambient temperature. When used in sealed area, confirm that it is the use in the range that does not exceed the maximum junction temperature.
- Confirm that operation temperature is within the specified range described in the product specification.
- ROHM shall not be in any way responsible or liable for failure induced under deviant condition from what is defined in this document.

## Precaution for Mounting / Circuit board design

- When a highly active halogenous (chlorine, bromine, etc.) flux is used, the residue of flux may negatively affect product performance and reliability.
- In principle, the reflow soldering method must be used on a surface-mount products, the flow soldering method must be used on a through hole mount products. If the flow soldering method is preferred on a surface-mount products, please consult with the ROHM representative in advance.

For details, please refer to ROHM Mounting specification

### Precautions Regarding Application Examples and External Circuits

1. If change is made to the constant of an external circuit, please allow a sufficient margin considering variations of the characteristics of the Products and external components, including transient characteristics, as well as static characteristics.
2. You agree that application notes, reference designs, and associated data and information contained in this document are presented only as guidance for Products use. Therefore, in case you use such information, you are solely responsible for it and you must exercise your own independent verification and judgment in the use of such information contained in this document. ROHM shall not be in any way responsible or liable for any damages, expenses or losses incurred by you or third parties arising from the use of such information.

### Precaution for Electrostatic

This Product is electrostatic sensitive product, which may be damaged due to electrostatic discharge. Please take proper caution in your manufacturing process and storage so that voltage exceeding the Products maximum rating will not be applied to Products. Please take special care under dry condition (e.g. Grounding of human body / equipment / solder iron, isolation from charged objects, setting of ionizer, friction prevention and temperature / humidity control).

### Precaution for Storage / Transportation

1. Product performance and soldered connections may deteriorate if the Products are stored in the places where:
  - [a] the Products are exposed to sea winds or corrosive gases, including Cl<sub>2</sub>, H<sub>2</sub>S, NH<sub>3</sub>, SO<sub>2</sub>, and NO<sub>2</sub>
  - [b] the temperature or humidity exceeds those recommended by ROHM
  - [c] the Products are exposed to direct sunshine or condensation
  - [d] the Products are exposed to high Electrostatic
2. Even under ROHM recommended storage condition, solderability of products out of recommended storage time period may be degraded. It is strongly recommended to confirm solderability before using Products of which storage time is exceeding the recommended storage time period.
3. Store / transport cartons in the correct direction, which is indicated on a carton with a symbol. Otherwise bent leads may occur due to excessive stress applied when dropping of a carton.
4. Use Products within the specified time after opening a humidity barrier bag. Baking is required before using Products of which storage time is exceeding the recommended storage time period.

### Precaution for Product Label

A two-dimensional barcode printed on ROHM Products label is for ROHM's internal use only.

### Precaution for Disposition

When disposing Products please dispose them properly using an authorized industry waste company.

### Precaution for Foreign Exchange and Foreign Trade act

Since concerned goods might be fallen under listed items of export control prescribed by Foreign exchange and Foreign trade act, please consult with ROHM in case of export.

### Precaution Regarding Intellectual Property Rights

1. All information and data including but not limited to application example contained in this document is for reference only. ROHM does not warrant that foregoing information or data will not infringe any intellectual property rights or any other rights of any third party regarding such information or data.
2. ROHM shall not have any obligations where the claims, actions or demands arising from the combination of the Products with other articles such as components, circuits, systems or external equipment (including software).
3. No license, expressly or implied, is granted hereby under any intellectual property rights or other rights of ROHM or any third parties with respect to the Products or the information contained in this document. Provided, however, that ROHM will not assert its intellectual property rights or other rights against you or your customers to the extent necessary to manufacture or sell products containing the Products, subject to the terms and conditions herein.

### Other Precaution

1. This document may not be reprinted or reproduced, in whole or in part, without prior written consent of ROHM.
2. The Products may not be disassembled, converted, modified, reproduced or otherwise changed without prior written consent of ROHM.
3. In no event shall you use in any way whatsoever the Products and the related technical information contained in the Products or this document for any military purposes, including but not limited to, the development of mass-destruction weapons.
4. The proper names of companies or products described in this document are trademarks or registered trademarks of ROHM, its affiliated companies or third parties.

### General Precaution

1. Before you use our Products, you are requested to carefully read this document and fully understand its contents. ROHM shall not be in any way responsible or liable for failure, malfunction or accident arising from the use of any ROHM's Products against warning, caution or note contained in this document.
2. All information contained in this document is current as of the issuing date and subject to change without any prior notice. Before purchasing or using ROHM's Products, please confirm the latest information with a ROHM sales representative.
3. The information contained in this document is provided on an "as is" basis and ROHM does not warrant that all information contained in this document is accurate and/or error-free. ROHM shall not be in any way responsible or liable for any damages, expenses or losses incurred by you or third parties resulting from inaccuracy or errors of or concerning such information.