

PART NAME: KNOB SCALE: 1:1 DATE: 4/7/87 DR. BY HD

THIS DRAWING IS THE PROPERTY OF DAVIES MOLDING COMPANY, IS SUBMITTED SOLELY AS A DESIGN OR ENGINEERING PROJECT. WE ACCEPT NO RESPONSIBILITY WHATSOEVER FOR THE PRACTICAL APPLICATION OF THE PIECES MADE TO THIS DESIGN.

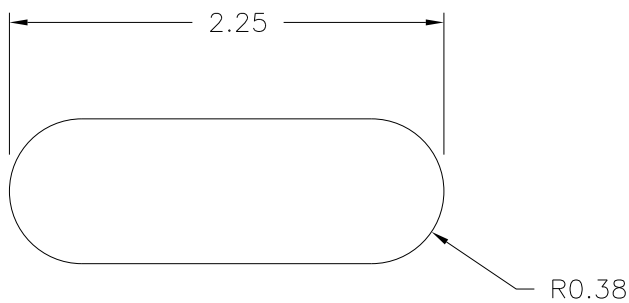

P/N	3081
M ^{NO.}	23
CAVITY	3081
CORE	3081
SLEEVE	3081
PIN	3081
INSERT	I1427



(B)

M ^{NO.}	2980
CAVITY	3081
CORE	3081
SLEEVE	3081
PIN	3081
INSERT	I1427

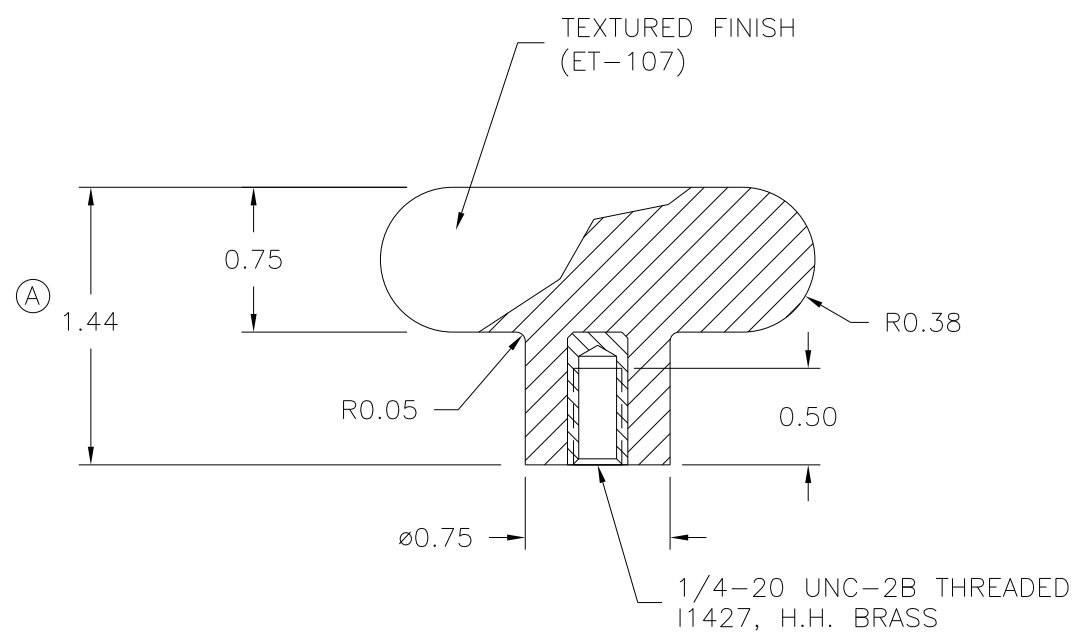

MATERIAL: POLYPROPYLENE (CLD)
COLOR: BLACK

TOLERANCES: UNLESS OTHERWISE SPECIFIED	DO NOT SCALE DRAWING	B	ADDED 2980 FRAME SET-UP	JAM	8/20/04
		-	RE-DID REDRAW	TL	11/11/99
DECIMALS: X.XXX ± .005 X.XX ± .015	MM: X.XX ± 0.15MM X.X ± 0.4MM	A	1.44 WAS 1.38	HD	7/5/96
		-	CAD REDRAW	HD	11/2/92
FRACTIONS ± 1/64	ANG. ± 1°	CHANGES			