

High Efficiency, 36V 100mA Synchronous Step-Down Converter

Purpose

The RT6208 is a high voltage Buck converter that can deliver up to 100mA output current from a wide input voltage range of 4.5V to 36V. This document explains the function and use of the RT6208 evaluation board (EVB) and provides information to enable operation and modification of the evaluation board and circuit to suit individual requirements.

Table of Contents

Purpose.....	1
Introduction.....	2
Key Performance Summary Table.....	2
Bench Test Setup Conditions.....	3
Schematic, Bill of Materials & Board Layout.....	4
More Information.....	6
Important Notice for Richtek Reference Designs.....	6

Introduction

General Product Information

The RT6208 is a high-efficiency, monolithic synchronous step-down DC/DC converter that can deliver up to 100mA output current from a 4.5V to 36V input supply. It requires only 25 μ A typical supply current at no load while maintaining output voltage regulation. The RT6208 achieves Boundary Conduction Mode (BCM) operation, low quiescent current and programmable high-side peak current limit, providing high efficiency over a wide range of load currents. It also provides soft-start protection to eliminate input current surge during start-up. The low current (3 μ A) shutdown mode provides output disconnect, enabling easy power management in battery-powered systems. The RT6208 is available in a SOT-23-6, SOT-23-8 and SOP-8 (Exposed Pad, with power good function) packages.

Product Feature

- Achieves Very High Efficiency in Low Load Conditions
- \pm 1% High Accuracy Feedback Voltage
- 4.5V to 36V Input Voltage Range
- 100mA Output Current
- Integrated High-Side and Low-Side Switches
- No Compensation Required
- Low Quiescent Current
- Adjustable Peak Current Limit
- Cycle-by-Cycle Over Current Protection
- Input Under Voltage Lockout
- Internal Soft-Start
- Thermal Shutdown Protection

Key Performance Summary Table

Key Features		Evaluation Board Number : PCB051_V1
Default Input Voltage	12V	
Max Output Current	100mA	
Default Output Voltage	1.8V, 3.3V, 5V Optional	
Default Marking & Package Type	RT6208GE, SOT-23-6	
Operation Mode	Boundary Conduction Mode (BCM)	
Other Key Features	4.5V to 36V Input Voltage Range Support duty up to 95%	
Protection	Cycle-by-Cycle Over Current Protection Thermal Shutdown	

Bench Test Setup Conditions

Headers Description and Placement

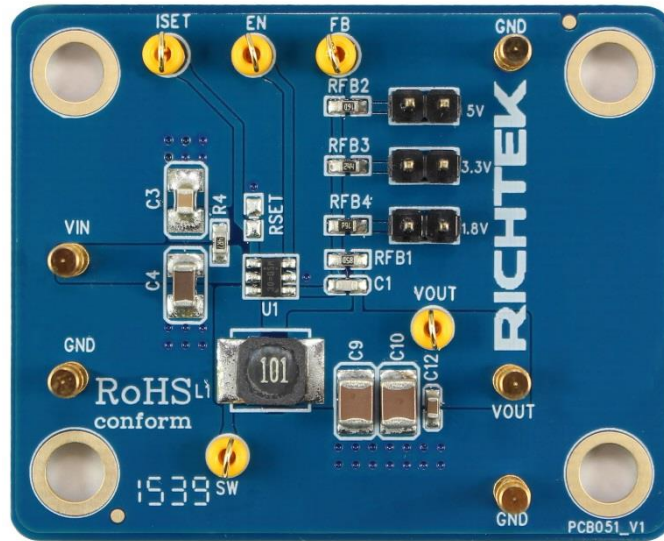

Please carefully inspect the EVB IC and external components, comparing them to the following Bill of Materials, to ensure that all components are installed and undamaged. If any components are missing or damaged during transportation, please contact the distributor or send e-mail to evb_service@richtek.com

Test Points

The EVB is provided with the test points and pin names listed in the table below.

Test point/ Pin name	Signal	Comment (expected waveforms or voltage levels on test points)
VIN	Input voltage	Input voltage range = 4.5V to 36V
VOUT	Output voltage	Default output voltage : 1.8V, 3.3V, 5V Optional Output voltage range = 0.8V to 5V
SW	Switching node test point	SW waveform
EN	Enable test point	Driving the EN pin high (>1.4V) will turn on the device again. Leaving the EN pin floating will pull the EN pin up to 2V internally and enable RT6208.
ISET	High-Side Peak Current Set Pin	A resistor from this pin to GND sets the high-side peak current limit. Leave floating for the maximum peak current, 225mA. Short this pin to GND for the minimum peak current, 50mA.
GND	Ground	Ground

Power-up & Measurement Procedure

1. Apply a 12V nominal input power supply ($4.5V < V_{IN} < 36V$) to the VIN and GND terminals.
2. There are 2-pin header 1.8V, 3.3V and 5V for output voltage. To use a jumper choose the output voltage level.
3. Verify the output voltage (approximately 1.8V, 3.3, 5.0V) between VOUT and GND.
4. Connect an external load up to 100mA to the VOUT and GND terminals and verify the output voltage and current.

Schematic, Bill of Materials & Board Layout

EVB Schematic Diagram

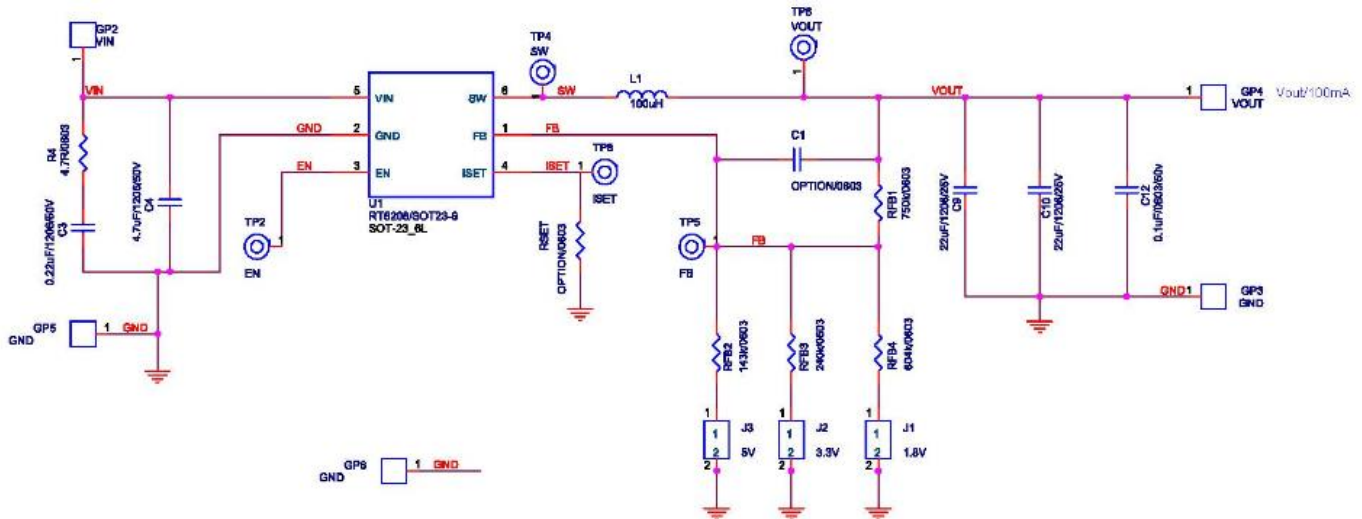

Bill of Materials

Reference	Qty	Part Number	Description	Package	Manufacture
C1	1	0603N101J500	100pF/0603	C-0603	WALSIN
C3	1	C2012X7R1H224KT000N	0.22 μ F/1206/50V	C-1210	TDK
C4	1	GRM31CR71H475KA12L	4.7 μ F/1206/50V	C-1210	MURATA
C9, C10	2	C3225X5R1E226MT	22 μ F/1206/25V	C-1210	TDK
C12	1	C1608X7R1H104KT000N	0.1 μ F/0603/50V	C-0603	TDK
Golden Pin	5	SIP-1P-GP	VIN, GND, VOUT	SIP-1P-GP	
J1	1		1.8V	SIP-2P	
J2	1		3.3V	SIP-2P	
J3	1		5V	SIP-2P	
L1	1	MSCDRI5010	100 μ H	5 x 5	Mag.Layer
RFB1	1	0603 750K 1%	750k/0603	R-0603	WALSIN
RFB2	1	0603 143K 1%	143k/0603	R-0603	WALSIN
RFB3	1	CR0603F240KP05	240k/0603	R-0603	EVER OHMS
RFB4	1	0603T-1-604K	604k/0603	R-0603	WALSIN
RSET	1	NC	OPTION/0603	R-0603	
R4	1	0603 4R70 1%	4.7R/0603	R-0603	WALSIN
Test Pin	5		EN, SW, FB, VOUT, ISET	sip-1p-tp	
U1	1	RT6208GE	DC/DC Converter	SOT-23-6	RICHTEK

EVB Layout

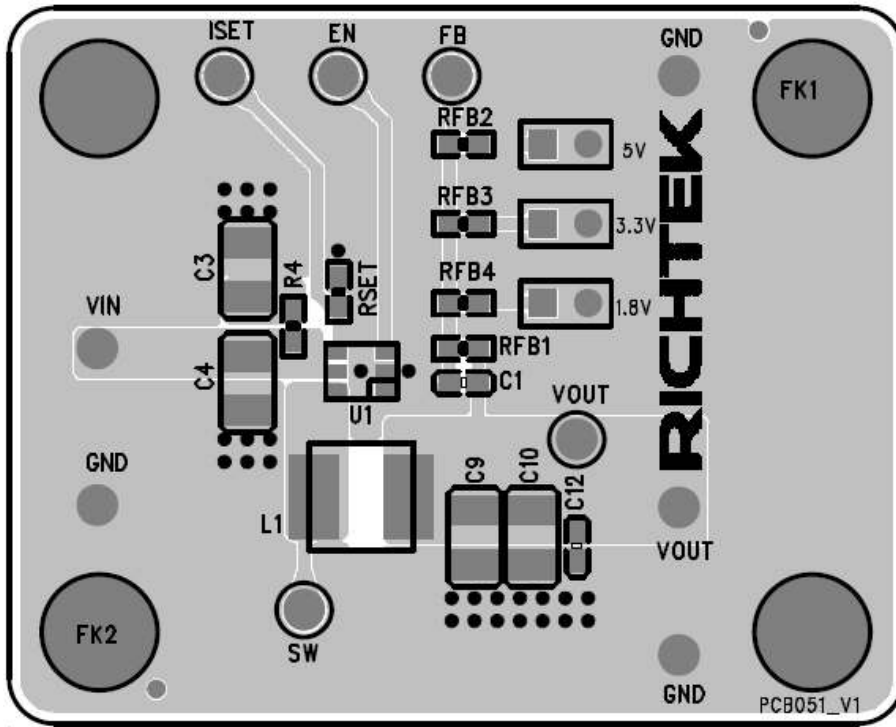

Top View

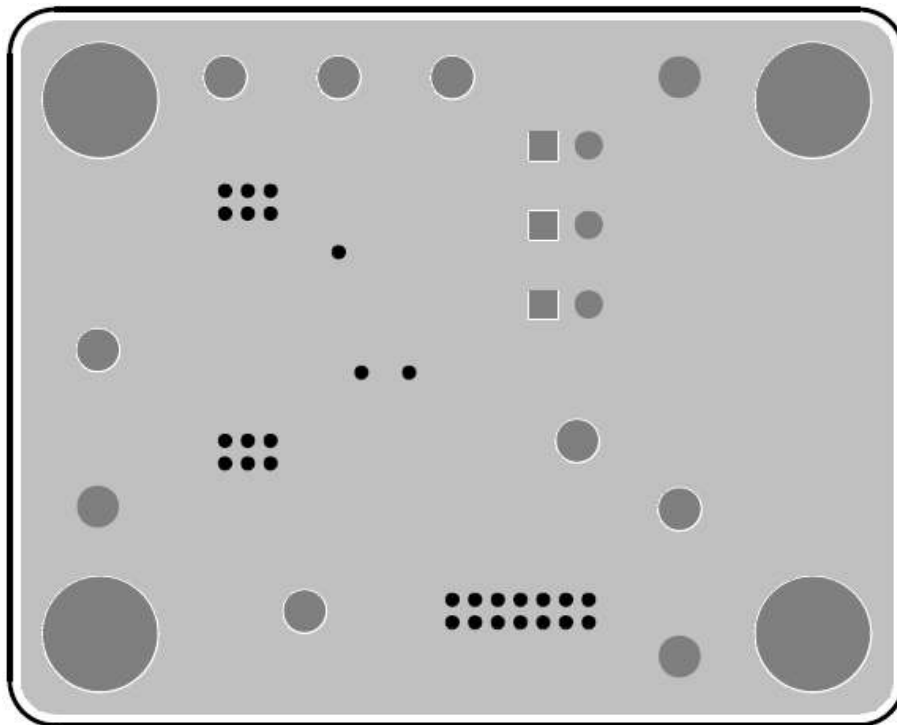

Bottom View

More Information

For more information, please find the related datasheet or application notes from Richtek website <http://www.richtek.com>.

Important Notice for Richtek Reference Designs

THIS DOCUMENT IS FOR REFERENCE ONLY, NOTHING CONTAINED IN THIS DOCUMENT SHALL BE CONSTRUED AS RICHTEK'S WARRANTY, EXPRESS OR IMPLIED, UNDER CONTRACT, TORT OR STATUTORY, WITH RESPECT TO THE PRESENTATION HEREIN. IN NO EVENT SHALL RICHTEK BE LIABLE TO BUYER OR USER FOR ANY AND ALL DAMAGES INCLUDING WITHOUT LIMITATION TO DIRECT, INDIRECT, SPECIAL, PUNITIVE OR CONSEQUENTIAL DAMAGES.