

NOTES:

1. FINISH: Parts shall have a smooth appearance, min.600 surface finish, with no gates and all flash removed
2. U.S. & Foreign Pat. Issued & Pend.

REVISIONS				
ECN #	REV	DESCRIPTION	DATE	INITIALS
	1	VARIOUS	7/94	JS
	2	WAS .275 IS .272	9/26/02	JS
	3	WAS .272 IS .265	10/17/02	JS
	001	REVISED PER ECR 111009AZ01	2/11/10	KH
145	002	CHANGE IN MATERIAL	7/12/10	KH

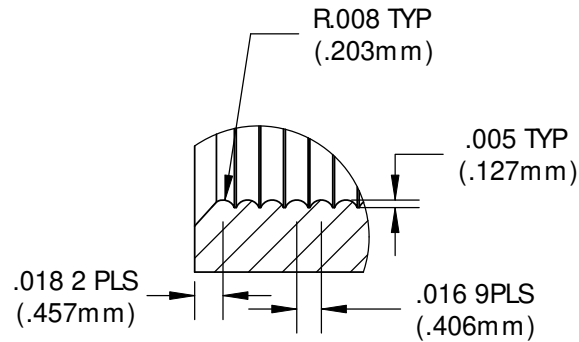
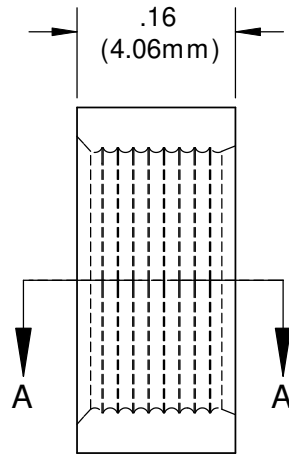

DETAIL B
SCALE 8 : 1

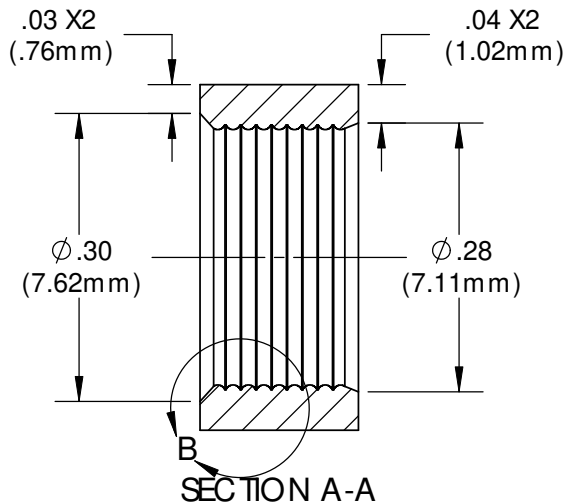

SECTION A-A

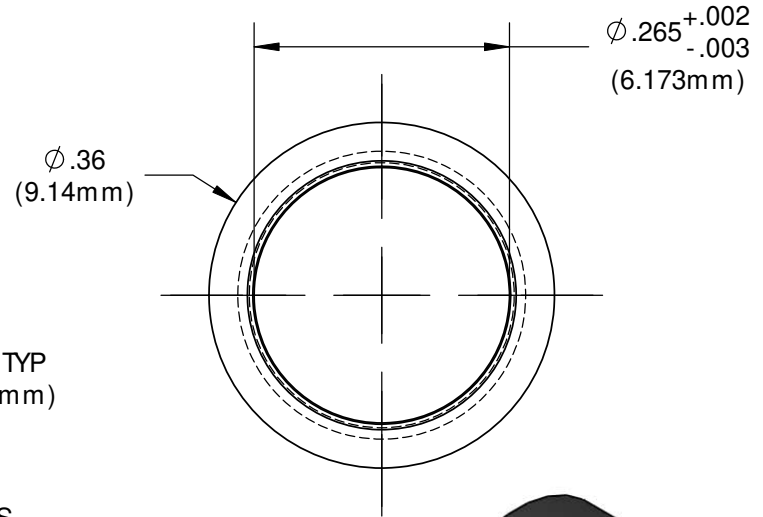

ISOMETRIC VIEW
4:1

UNLESS OTHERWISE SPECIFIED DIMENSIONS ARE IN INCHES: ANGLES ± 1° DECIMALS .X ± .020 .XX ± .010 .XXX ± .005 BREAK ALL CORNERS AND SHARP EDGES .250 MAX		MATERIAL 50% POLYPROPYLENE (BLACK) 50% ELASTOCON		VISUAL COMMUNICATIONS COMPANY 190 Bosstick Boulevard, Suite 101 San Marcos, CA 92069 USA Phone (760) 560-1300 Fax (760) 560-1301 email vccsales@vccsite.com	
THIRD ANGLE PROJECTION		FINISH SEE NOTES		TITLE: CLIPMOUNT RING RNG 268	
PROPRIETARY AND CONFIDENTIAL THE INFORMATION CONTAINED IN THIS DRAWING IS THE SOLE PROPERTY OF VISUAL COMMUNICATIONS COMPANY, INC. ANY REPRODUCTION IN PART OR AS A WHOLE WITHOUT THE WRITTEN PERMISSION OF VISUAL COMMUNICATIONS COMPANY, INC. IS PROHIBITED.		APPROVALS	DATE	SIZE A	DWG. NO. RNG 268_E
		DRAWN K.Howard	2/11/10	REV 002	
		CHECKED DPZ	2/22/10	SCALE: 5:1	
		DO NOT SCALE DRAWING		SHEET 1 OF 1	