

Description

Miniaturised single pole thermal circuit breaker with push-to-reset tease free, trip-free, snap action mechanism (R-type TO CBE to EN 60934). Available in versions for PCB or panel mounting, snap-in or threadneck, or as an integral type. Manual release facility optional for type 105.

Approved to CBE standard EN 60934 (IEC 60934). For higher current ratings see type 1140.

Typical applications

Motors, transformers, solenoids, printed circuit boards, hand-held machines and appliances, marine applications, caravans.

Ordering information

Type No.	Description
104	PCB mounting type (-PR), or integral type (-P30/P10)
105	snap-in panel mounting
106	threadneck panel mounting with hex and knurled nut * (international version)
106-M1	as 106 but for standard fuseholder cut-out * (double D) hex nut and plastic knurled nut Y307 117 02
106-M2	threadneck panel mounting 3/8-27UNS with collar, hex nut and knurled nut* (US version) with plastic knurled nut + PTRP Y307 117 02
106-M3	as 106-M2 but for standard fuseholder cut-out (double D)

Terminal design	
P10	blade terminals A6.3-0.8 (QC .250)
P30	blade terminals A2.8-0.8 (QC .110)
PR	solder terminal pins for PCB mounting (type 104 only)
PR2	PCB mounting (vertical), type 104 only up to 6 A
PR3	PCB mounting (vertical), type 104 only

Shunt terminal (optional)	
A3	same as main terminals (up to I _N 6 A/3 A max. load)

Manual release facility	
H	type 105 only

Auxiliary contacts (optional)	
Si51	type 104 only

Current ratings	
	0.05...10 A

106-M2 - P30 - [] - [] - [] - 5 A = ordering example

The exact part number required can be built up from the table of choices shown above. Ordering references for optional features should be omitted if not required.

* mounting hardware bulk shipped

Standard current ratings and typical internal resistance values

Current rating (A)	Internal resistance (Ω)	Current rating (A)	Internal resistance (Ω)
0.05	285	1.8	0.28
0.08	134	2	0.25
0.1	81	2.5	0.18
0.2	22	3	0.11
0.3	8.7	3.5	0.076
0.4	5.5	4	0.067
0.5	3.3	4.5	0.051
0.6	2.45	5	≤ 0.05
0.7	1.6	6	≤ 0.05
0.8	1.45	7	≤ 0.05
1	0.9	8	≤ 0.05
1.2	0.6	10	≤ 0.05
1.5	0.4		

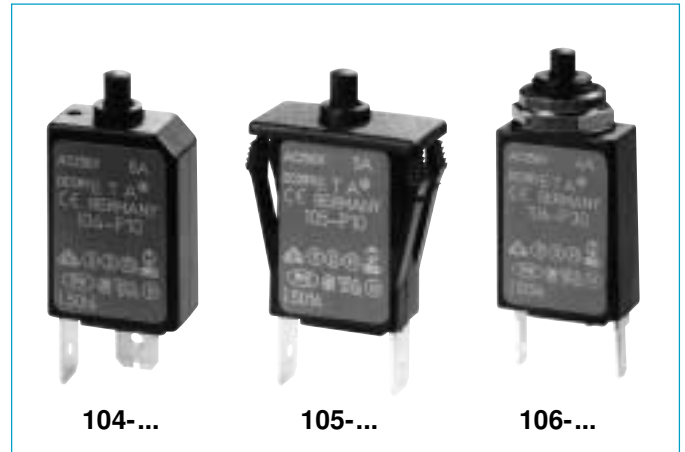

Technical data

Voltage rating	AC 240 V; DC 48 V (UL: AC 250 V)	
Current ratings	0.05...10 A	
Auxiliary circuit	0.5 A, AC 240 V, DC 28 V	
Typical life	0.05...5 A:	3,000 operations at 2 x I _N
	6 ...8 A:	500 operations at 2 x I _N
with -H:	10 A:	50 operations at 2 x I _N
	0.05...8 A:	2,000 operations at 1 x I _N
	10 A:	200 operations at 1 x I _N
Ambient temperature	-20...+60 °C (-4...+140 °F) T 60	
Insulation co-ordination (IEC 60664 and 60664 A)	Rated impulse withstand voltage	Pollution degree 2
	2.5 kV	reinforced insulation in operating area
Dielectric strength (IEC 60664 and 60664A) operating area	Test voltage AC 3,000 V	
	Insulation resistance >100 MΩ (DC 500 V)	
Interrupting capacity I _{cn}	0.05 ... 2 A	6 x I _N
	2.5 ...10 A	5 x I _N
Interrupting capacity (UL 1077)	I _N	U _N
	0.05...10 A	AC 250 V 2000 A
	0.05...10 A	DC 48 V 200 A
Degree of protection (IEC 60529/DIN 40050)	operating area	IP 40
	terminal area	IP 00
Vibration	10 g (57-500 Hz), ±0.76 mm (10-57 Hz), to IEC 60068-2-6, test Fc, 10 frequency cycles/axis	
Shock	25 g (11 ms) to IEC 60068-2-27, test Ea	
Corrosion	96 hours at 5 % salt mist, to IEC 60068-2-11, test Ka	
Humidity	240 hours at 95 % RH, to IEC 60068-2-3, test Ca	
Mass	approx. 10 g	

Approvals

Authority	Voltage ratings	Current ratings
VDE (EN 60934), SEV	AC 240 V	0.05...8 A
	DC 48 V	0.05...10 A
Demko	AC 250 V, DC 28 V	0.05...10 A
CSA, UL	AC 250 V, DC 48 V	0.05...10 A
Semko	AC 250 V, DC 48 V	0.1...10 A
Kema (EN 60934)	AC 240 V	0.05...8 A
	DC 48 V	0.05...10 A

Circuit breakers with -Si51 not approved

Dimensions

104-P30

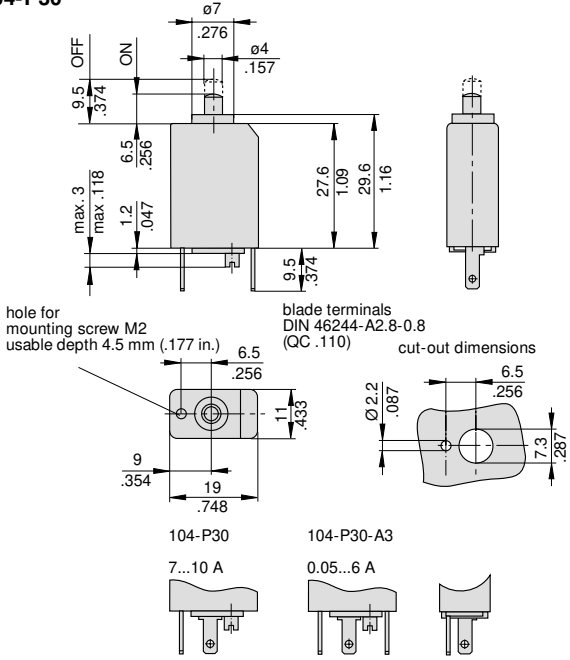

104-PR-(A3)-Si51

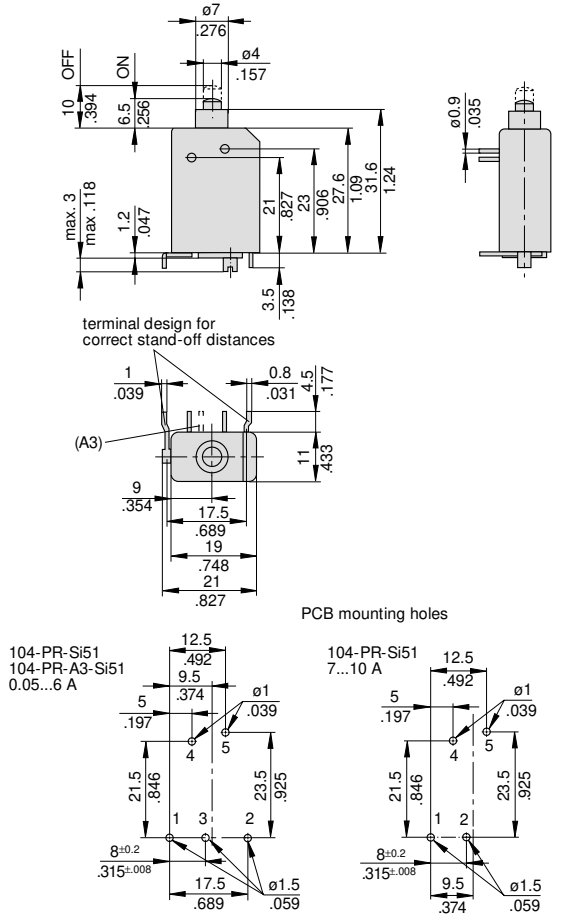

104-PR

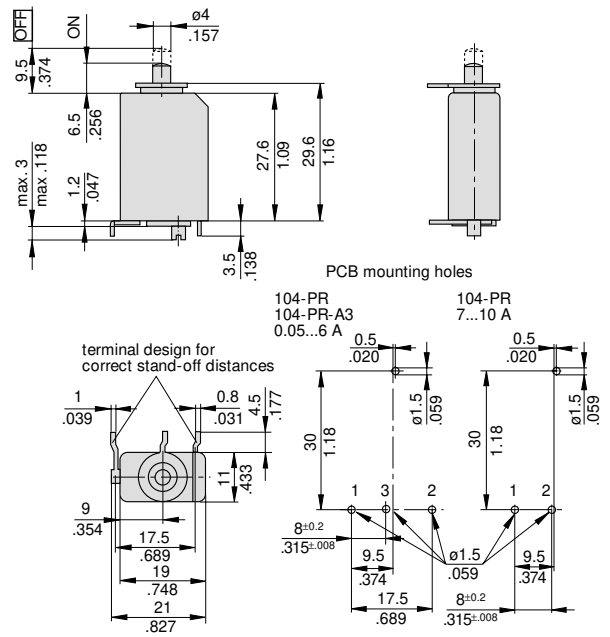

104-PR3

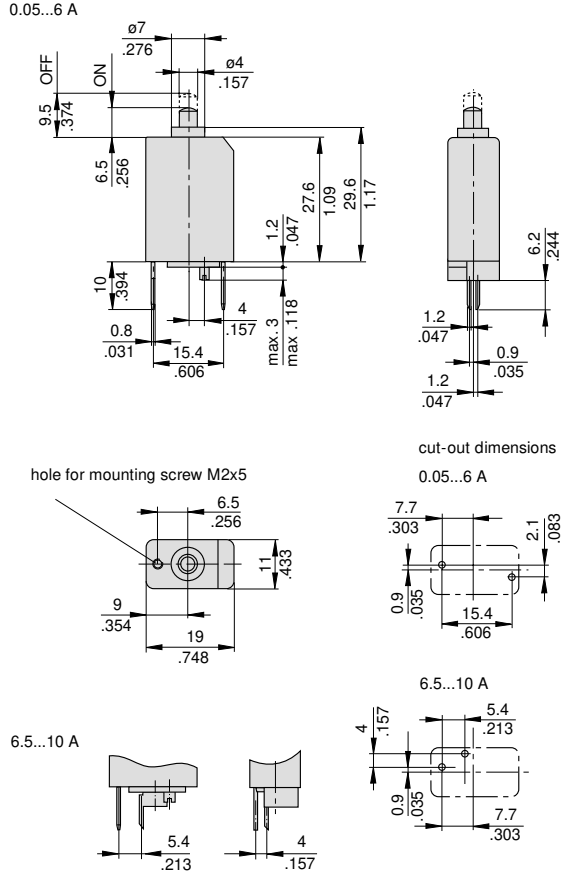

This is a metric design and millimeter dimensions take precedence ($\frac{mm}{inch}$)

Dimensions

104-PR2

0.05...6 A

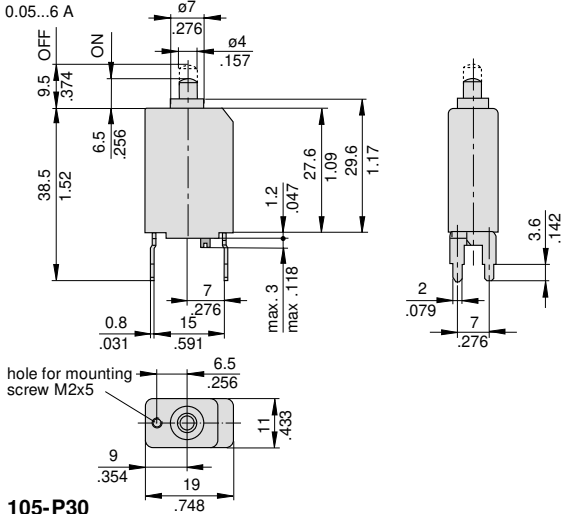

105-P30

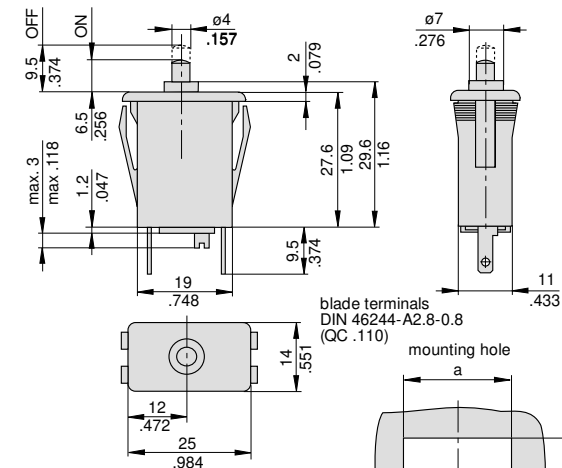

d	a	b
0.8	21.9	11.3 ^{+0.3}
1.0	22	11.3 ^{+0.15}
1.5	22.1	11.3 ^{+0.15}
2-3	22.2	11.3 ^{+0.15}

105-P307...10 A

105-P30-A3
0.05...6 A

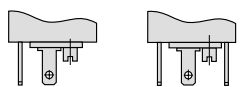

105-P30-H

0.05...6 A

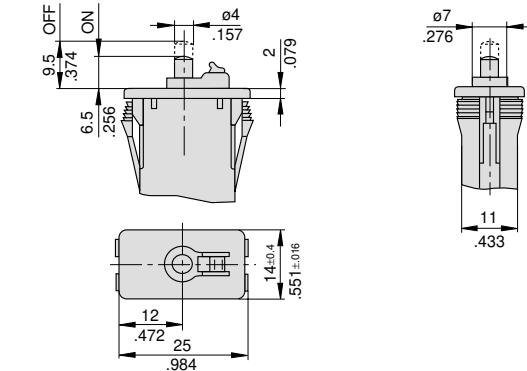

106-P30

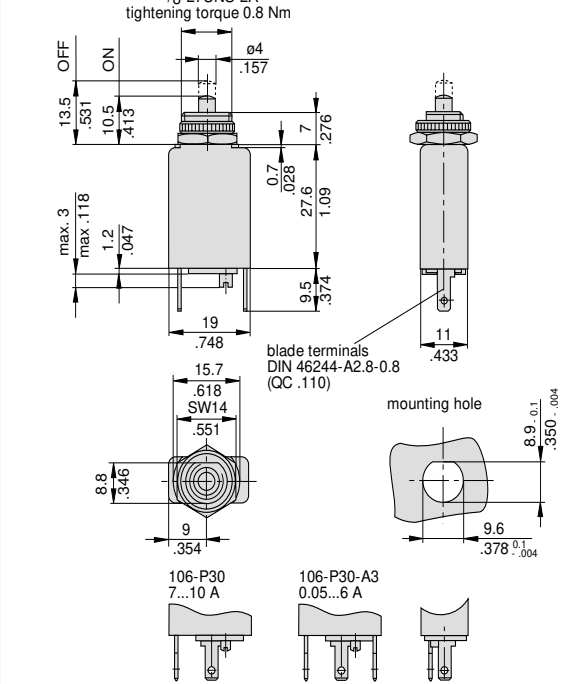

106-M1

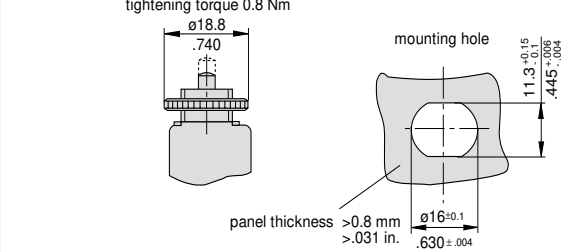

106-M2

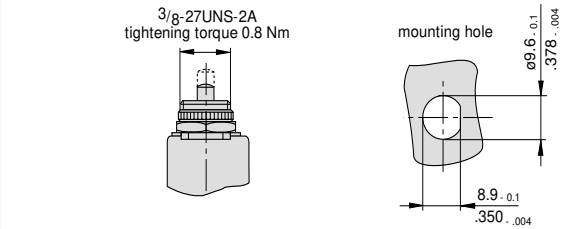

106-M3

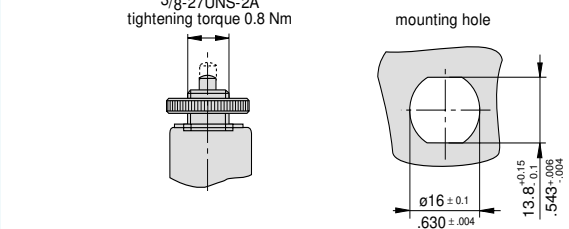

This is a metric design and millimeter dimensions take precedence (mm/inch)

Installation drawings

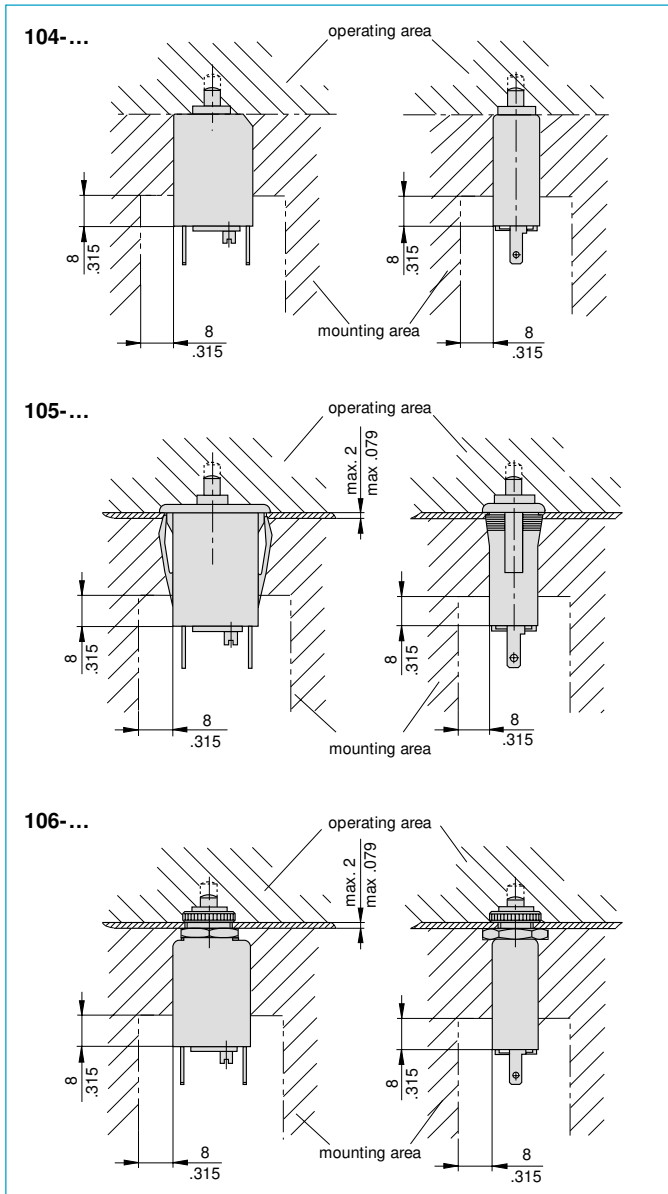

Internal connection diagrams

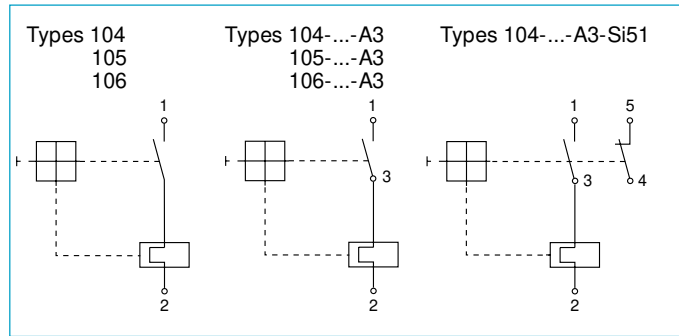

Typical time/current characteristics +23°C/+73.4°F

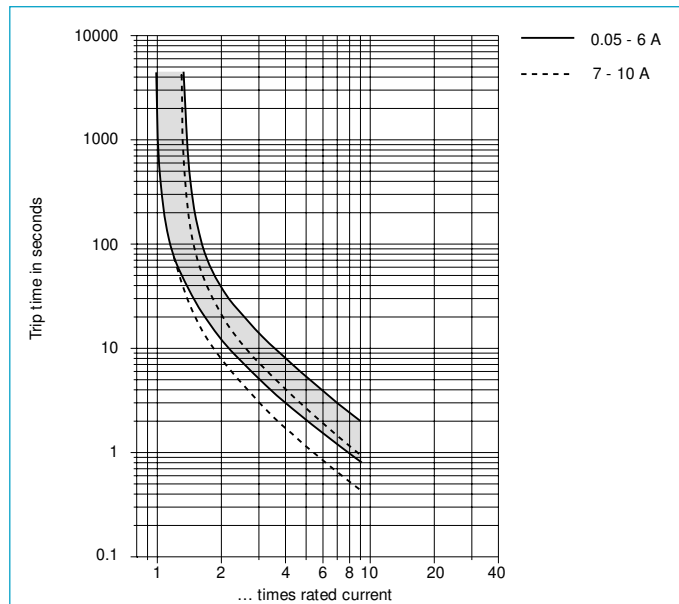

The time/current characteristic curve depends on the ambient temperature prevailing. In order to eliminate nuisance tripping, please multiply the circuit breaker current ratings by the derating factor shown below. See also section 9 – Technical information.

Ambient temperature °F	-4	+14	+32	+73.4	+104	+122	+140
°C	-20	-10	0	+23	+40	+50	+60
Multiplication factor	0.76	0.84	0.92	1	1.08	1.16	1.24

Terminal design

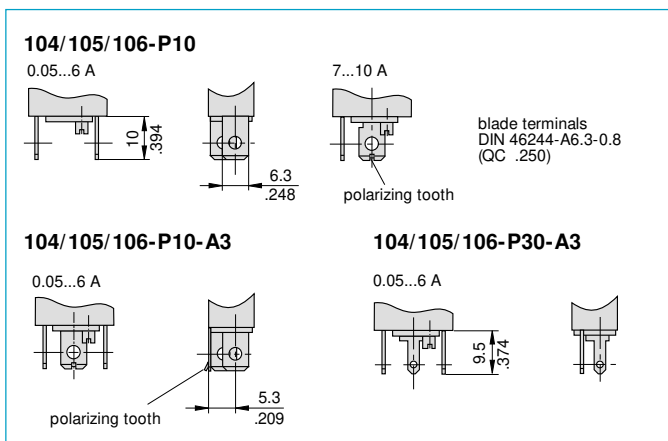

Accessories

Water splash cover (transparent)/knurled nut assembly
(type 106-... only)
X 201 285 01
Degree of protection IP 64

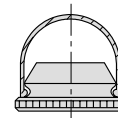

This is a metric design and millimeter dimensions take precedence ^(mm)/_(inch)

All dimensions without tolerances are for reference only. In the interest of improved design, performance and cost effectiveness the right to make changes in these specifications without notice is reserved. Product markings may not be exactly as the ordering codes. Errors and omissions excepted.