

6

5

4

3

2

1

MATERIAL NUMBER	ENGINEERING NUMBER	FINISHED LENGTH
130010-1312	116020A01F030	3.00' +1.75' -0 [0.9M +44.5mm -0]
130010-1316	116020A01F060	6.00' +2.19' -0 [1.8M +55.6mm -0]
130010-1327	116020A01F120	12.00' +3.50' -0 [3.7M +88.9mm -0]
130010-1338	116020A01F200	20.00' +6.50' -0 [6.1M +165.1mm -0]

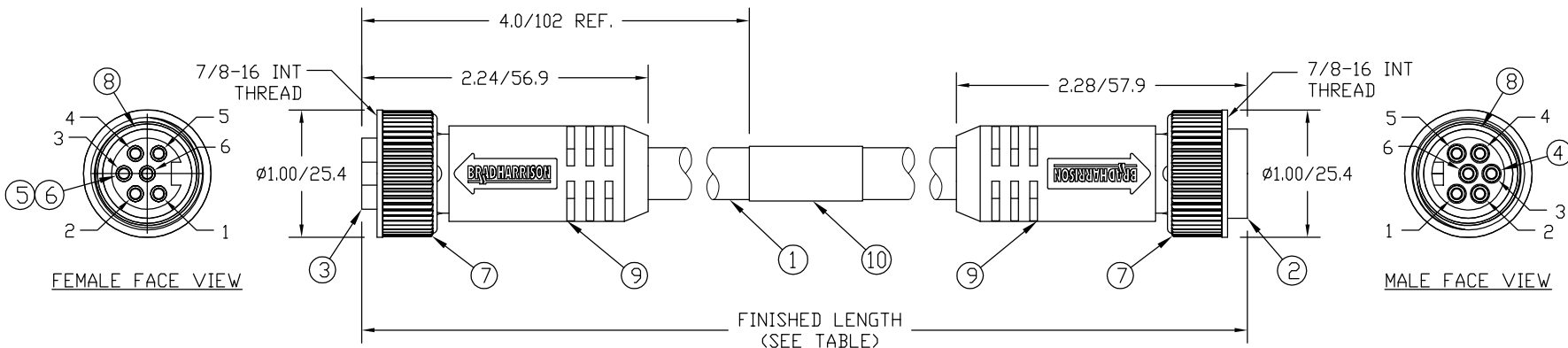
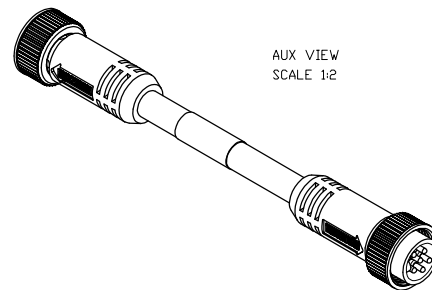

- NOTES:
- 1) MATERIALS: SEE TABLE
 - 2) FINISHES: SEE TABLE
 - 3) CABLE: #16/5 ST00W/ST PVC
 - 4) ELECTRICAL DATA:
MAX. VOLTAGE: 600 VAC/VDC
MAX. CURRENT 8 AMPS
 - 5) ENVIRONMENTAL:
PROTECTION IP67
TEMPERATURE RANGE: -20°C TO 105°C
 - 6) WRAP LABEL IS MARKED WITH P/N, DATE CODE, VOLTAGE & AMPERAGE.
 - 7) ASSEMBLY IS RoHS COMPLIANT.

S1		P1
1	WHITE	1
2	RED	2
3	GREEN/YELLOW - GND	3
4	ORANGE	4
5	BLACK	5
6	BLUE	6

WIRING DIAGRAM

ITEM	QTY.	DESCRIPTION	MATERIAL	FINISH
10	1	LABEL	MYLAR	BLACK/YELLOW
9	2	OVERMOLD	PVC	YELLOW
8	2	FRICTION RING	NYLON	WHITE
7	2	COUPLING NUT	ZINC DIECAST	BLACK E-COAT
6	6	SOCKET SLEEVE	STAINLESS STEEL	
5	6	CONTACT SOCKET	BRASS	GOLD OVER NICKEL
4	6	CONTACT PIN	BRASS	GOLD OVER NICKEL
3	1	FEMALE INSERT, 6 POLE	PVC	YELLOW
2	1	MALE INSERT, 6 POLE	PVC	YELLOW
1	1	CABLE, ST00W/ST #16/6	PVC JACKET	YELLOW

RELEASED DRAWING EC NO: WNA2009-0846 DRWN: LHARTMAN 8/10/09 CHKD: BWOODMAN09/08/11 APPR: JFMURPHY 2009/08/14	QUALITY SYMBOLS ▽=0 ∇=0	GENERAL TOLERANCES (UNLESS SPECIFIED)		DIMENSION STYLE IN/MM		SCALE 1:1	DESIGN UNITS INCH	THIRD ANGLE PROJECTION
		4 PLACES ±--- ±---	mm INCH	DRAWN BY LHARTMAN	DATE 2009/08/10	TITLE MINI-CHANGE CORDSET 6P MALE/FEMALE ST/ST #16/6 YELLOW ST00W/ST		
		3 PLACES ±--- ±---	±--- ±---	CHECKED BY BWOODMAN	DATE 2009/08/11	MOLEX INCORPORATED		
		2 PLACES ±--- ±0.1 1 PLACE ±0.3 ±---	ANGULAR ±---°	APPROVED BY SEE TABLE		MATERIAL NO. SD-130010-007	SHEET NO. 1 OF 1	
DRAFT WHERE APPLICABLE MUST REMAIN WITHIN DIMENSIONS		THIS DRAWING CONTAINS INFORMATION THAT IS PROPRIETARY TO MOLEX INCORPORATED AND SHOULD NOT BE USED WITHOUT WRITTEN PERMISSION						

6

5

4

3

2

1