

TECHNICAL CHARACTERISTICS

MATERIAL
 INSULATOR: ABS
 FLAMABILITY RATING: UL94-HB
 COLOR: BLACK
 SCREW: UNC 4-40

ENVIRONMENTAL
 COMPLIANCE: LEAD FREE AND ROHS

PACKAGING: BAG

NOTE : TO NOT BE PLUG WITH 618 0xx 221 923

A

B

C

RoHS Compliant

G	17-NOV-14	PACKAGING	AS
REV	DATE	FILE	BY

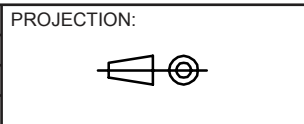

GENERAL TOLERANCE
 .X = +/- 0.2
 .XX = +/- 0.15



APPROVAL: NPr

UNIT: MM
 SCALE:
 SHEET: 1/3
 DRAW: AS

DESCRIPTION: WR-DSUB - PLASTIC HOOD SMALL TOP ENTRY 4640 SCREW
 WERI PART NO: 618 009 214 622

SIZE
A4

D

1

2

3

4

5

A

B

C

D

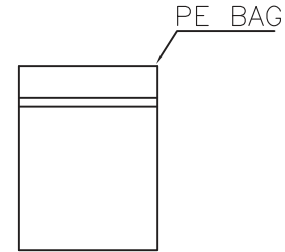
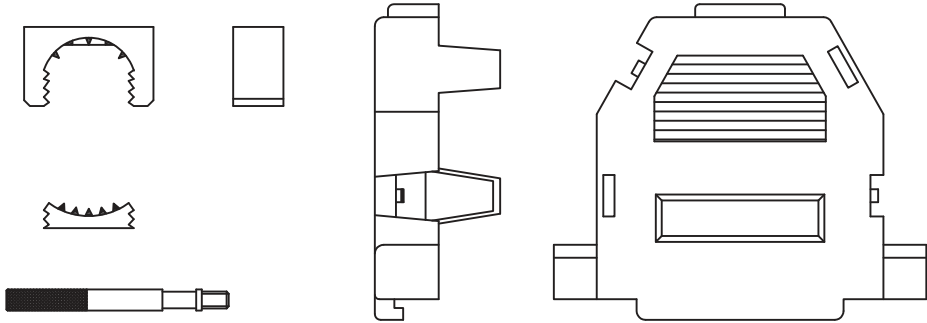
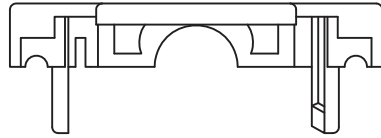

50 Pcs/Bag
10 Bags/Carton
500 Pcs/Carton

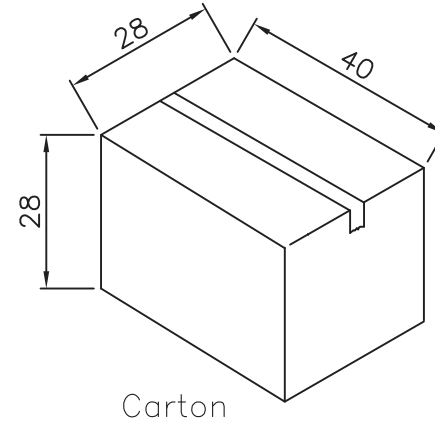

Carton

RoHS Compliant

G			
F			
E			
D			
C			
B			
A	17-NOV-14	PDF	AS
REV	DATE	FILE	BY

PROJECTION:

GENERAL TOLERANCE
.X = +/- 0.2
.XX = +/- 0.15

DESCRIPTION: WR-DSUB - PLASTIC HOOD SMALL TOP ENTRY 4640 SCREW

APPROVAL: NPr

UNIT: MM
SCALE:
SHEET: 2/3
DRAW: AS

WERI PART NO: 618 009 214 622

SIZE
A4

1

2

3

4

5

Cautions and Warnings:

This electronic component is designed and developed with the intention for use in general electronics equipments.

Before incorporating the components into any equipments in the field such as aerospace, aviation, nuclear control, submarine, transportation, (automotive control, train control, ship control), transportation signal, disaster prevention, medical, public information network etc. where higher safety and reliability are especially required or if there is possibility of direct damage or injury to human body, Würth Elektronik must be asked for a written approval.



In addition, even electronic component in general electronic equipments, when used in electrical circuits that require high safety, reliability functions or performance, the sufficient reliability evaluation-check for the safety must be performed before by the user before usage.

A

B

C

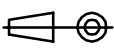
RoHS Compliant

G				PROJECTION: 	GENERAL TOLERANCE .X = +/- 0.2 .XX = +/- 0.15		
F							
E							
D							
C				APPROVAL: JC	UNIT: MM	DESCRIPTION: DISCLAIMER	SIZE A4
B					SCALE:		
A	10-SEP-14	PDF	QL		SHEET: 3/3	WERI PART NO: DISCLAIMER	
REV	DATE	FILE	BY		DRAW: QL		

D