

TABLE 1				
CONTACT SPECIFICATION				
-XX	-S, -D, -T	-S-RA	-D-RA	-T-RA
-01	C-15-1-X	N/A	N/A	N/A
-02	C-15-2-X	C-15-2-X	C-15-2-X	C-15-2-X
			C-15-3-X	C-15-3-X
-03	C-15-3-X	C-15-3-X	C-15-3-X	N/A
			C-15-4-X	N/A
-04	C-15-4-X	C-15-4-X	N/A	N/A
-21	C-60-1-X	N/A	N/A	N/A
	C-60-2-X	C-60-2-X	C-60-2-X	C-60-2-X
-22			C-60-3-X	C-60-3-X
				C-60-4-X
-23	C-60-3-X	C-60-3-X	C-60-3-X	N/A
			C-60-4-X	N/A
-24	C-60-4-X	C-60-4-X	N/A	N/A

DO NOT SCALE FROM THIS PRINT

SSQ-1 XX-XX-XXX-X-XX-XXX-XX-XX

NO OF POSITIONS
-01 THRU -50 (PER ROW)

LEAD STYLE
(SEE TABLE 1)
-01 THRU -04: STANDARD INSERTION FORCE
-21 THRU -24: LOW INSERTION FORCE

PLATING SPECIFICATION

-G: 20µ" GOLD IN CONTACT AREA, 3µ" SELECTIVE GOLD ON TAIL

-T: MATTE TIN ON ENTIRE PIN (NOT AVAILABLE FOR -21 THROUGH -24 LEAD STYLES)

-S: 30µ" SELECTIVE GOLD IN CONTACT AREA, MATTE TIN ON TAIL

-H: 30µ" GOLD IN CONTACT AREA, 3µ" SELECTIVE GOLD ON TAIL

-F: 3µ" SELECTIVE GOLD IN CONTACT AREA, MATTE TIN ON TAIL

-TL: TIN/LEAD (90/10±5%) ON ENTIRE PIN (AVAILABLE ONLY ON LEAD STYLE -01)

-TM: MATTE TIN ON ENTIRE PIN (NOT AVAILABLE FOR -21 THROUGH -24 LEAD STYLES)

-SM: 30µ" SELECTIVE GOLD IN CONTACT AREA, MATTE TIN ON TAIL

-FM: 3µ" SELECTIVE GOLD IN CONTACT AREA, MATTE TIN ON TAIL

-L: 10µ" SELECTIVE GOLD IN CONTACT AREA, MATTE TIN ON TAIL

-STL: 30µ" SELECTIVE GOLD IN CONTACT AREA, TIN/LEAD (90/10±5%) ON TAIL (AVAILABLE ONLY ON LEAD STYLE -01)

OPTION

** -MW: METAL WASHER (SEE FIG 7, SHT 3) (N/A WITH -LL OR -RA) (N/A WITH -T) (AVAILABLE ON -01, -02, -21, & -22 STYLES ONLY) (AVAILABLE ON POS -02 THRU -30 ONLY)

OPTION

-LL: LOCKING LEAD (SEE FIG 6, SHT 2) (N/A WITH SINGLE ROW, 1 OR 2 POS)

POLARIZATION OPTION

INDICATE POS (SEE FIG 8, SHT 3)

OPTION

-RA: RIGHT ANGLE (SEE FIG 2, SHT 2) (N/A ON LEAD STYLE -01)

ROW SPECIFICATION

-S: SINGLE, USE SSW-XX-S

-D: DOUBLE, USE SSW-XX-D

-T: TRIPLE, USE SSW-XX-T

-Q: TRIPLE (SEE FIG 4, SHT 2) USE SSW-XX-T (-T WITH ONLY 2 OUTER ROWS FILLED)

-P: POLARIZED, USE SSW-XX-P (SEE FIG 5, SHT 2)

** - MW OPTION, DO NOT DESIGN IN. SAMTEC WILL ONLY SUPPORT EXISTING BUSINESS AS OF 02/12/2002

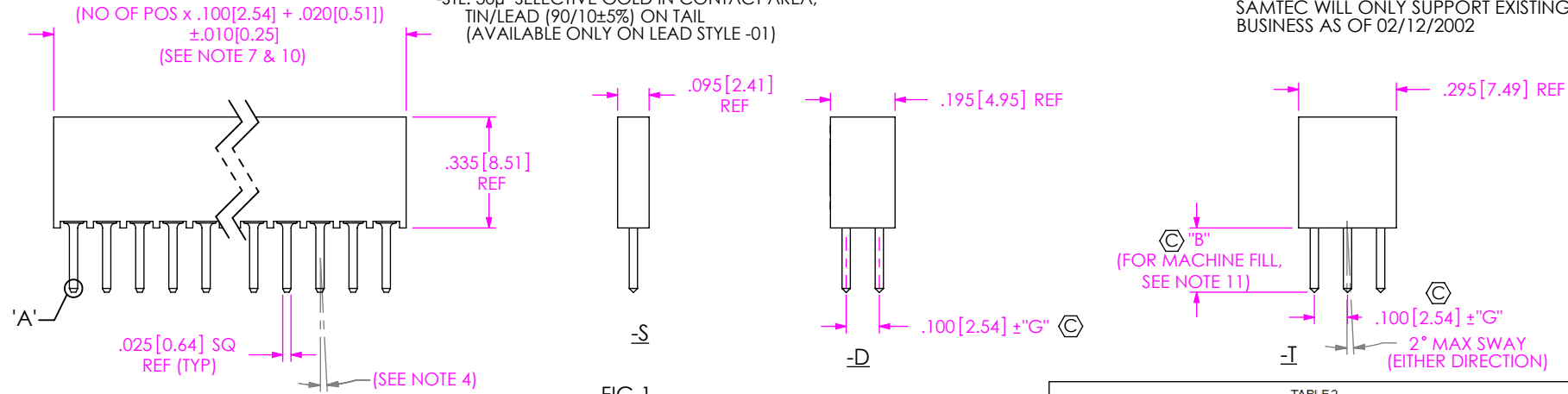

NOTES:

- ⊕ REPRESENTS A CRITICAL DIMENSION.
- MINIMUM PUSHOUT FORCE: 1.0 LB.
- MAXIMUM ALLOWABLE BOW: .003[.08] INCH/INCH.
- MAXIMUM ALLOWABLE SWAY: HAND FILL 4° (TYP). MACHINE FILL 1° (TYP).
- MAXIMUM VARIATION BETWEEN PIN ROWS: .010[0.25].
- END WALLS AFTER CUTTING SHOULD BE .020 ± .003 [0.51 ± .08]
- MAXIMUM CUT FLASH: .010[0.25].
- SHEAR LOCATION TO BE WITHIN .001[0.03] OF THE BREAK OFF CENTER LOCATION FOR MACHINE FILL.
- NOTCH ON -P-RA OPTION TO BE ORIENTED AS SHOWN.
- NO FLASH IS ALLOWED BELOW LEADS OR IN HOLES OF BODY.
- + .000[0.00] / - .005[0.13] FOR MACHINE FILL ONLY, SSQ-1XX-XX-X-S, SSQ-1XX-XX-X-D, SSQ-1XX-XX-X-T (IN-PROCESS), SSQ-1XX-XX-X-S-RA.

FIG 1
SSQ-1 XX-XX-X SHOWN

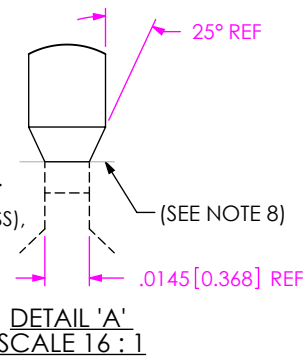

CONTACT	TABLE 2				
	"B"	"G"	"C" REF		
	-S(-RA), -D, -T	-D, -T	-S-RA	-D-RA	-T-RA
-01, -21	0.104 [2.64]	.005 [13]	N/A	N/A	N/A
-02, -22	0.194 [4.93]	.005 [13]	0.100 [2.54]	0.100 [2.54]	0.100 [2.54]
-03, -23	0.394 [10.01]	+0.010/-0.012 [+2.5/-3.1]	0.300 [7.62]	0.300 [7.62]	N/A
-04, -24	0.584 [14.83]	+0.010/-0.012 [+2.5/-3.1]	0.490 [12.45]	N/A	N/A

UNLESS OTHERWISE SPECIFIED, DIMENSIONS ARE IN INCHES.

TOLERANCES ARE:

DECIMALS ANGLES

.XX: ±.01[0.3] 2°

.XXX: ±.005[0.13]

.XXXX: ±.0020[0.051]

PROPRIETARY NOTE

THIS DOCUMENT CONTAINS CONFIDENTIAL AND PROPRIETARY INFORMATION AND ALL DESIGN, MANUFACTURING, REPRODUCTION, USE, PATENT RIGHTS AND SALES RIGHTS ARE EXPRESSLY RESERVED BY SAMTEC, INC. THIS DOCUMENT SHALL NOT BE DISCLOSED, IN WHOLE OR PART, TO ANY UNAUTHORIZED PERSON OR ENTITY NOR REPRODUCED, TRANSFERRED OR INCORPORATED IN ANY OTHER PROJECT IN ANY MANNER WITHOUT THE EXPRESS WRITTEN CONSENT OF SAMTEC, INC.



520 PARK EAST BLVD, NEW ALBANY, IN 47150
PHONE: 812-944-6733 FAX: 812-948-5047
e-Mail info@SAMTEC.com code 55322

MATERIAL: DO NOT SCALE DRAWING SHEET SCALE: 2:1
INSULATOR: LCP, UL 94 VO, COLOR: BLACK
CONTACT: PHOS BRONZE

DESCRIPTION: ASSEMBLY, SOCKET STRIP .025[0.64] SQ TAIL
DWG. NO. SSQ-1 XX-XX-XXX-X-XX-XXX-XX-X

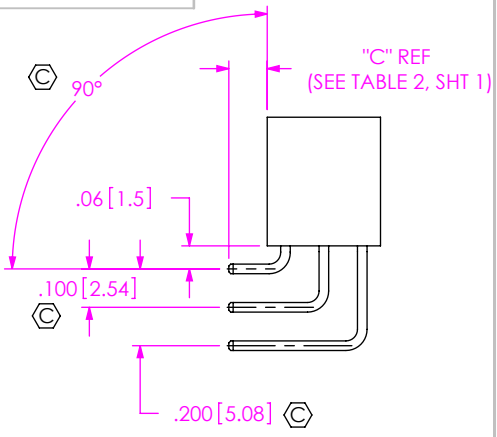

FIG 2
(DIFFERENT AS SHOWN,
OTHERWISE SAME AS FIG 1)
SSQ-1XX-X-S-RA
SSQ-1XX-X-D-RA
SSQ-1XX-X-T-RA
SSQ-1XX-X-P-RA

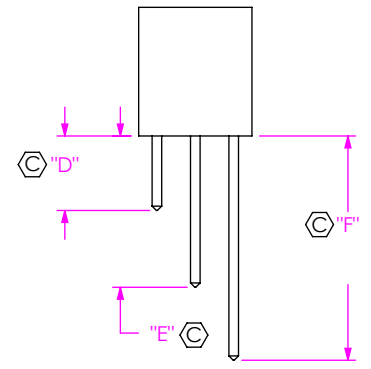

FIG 3
IN-PROCESS RIGHT ANGLE

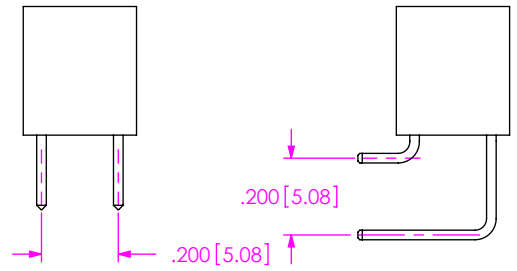

FIG 4
SSQ-1XX-XXX-X-Q-RA SHOWN
(DIFFERENT AS SHOWN,
OTHERWISE SAME AS FIG 1, FIG 2)

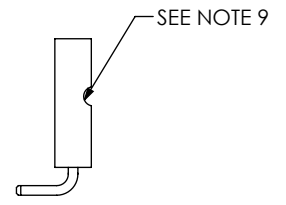
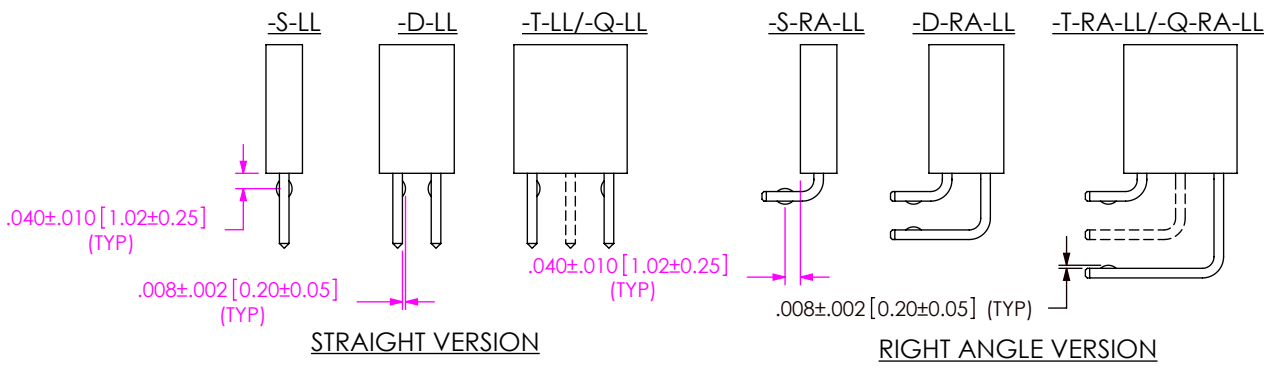

FIG 5
SSQ-1XX-XXX-X-RA-P SHOWN
(DIFFERENT AS SHOWN,
OTHERWISE SAME AS FIG 2)



STRAIGHT VERSION

RIGHT ANGLE VERSION

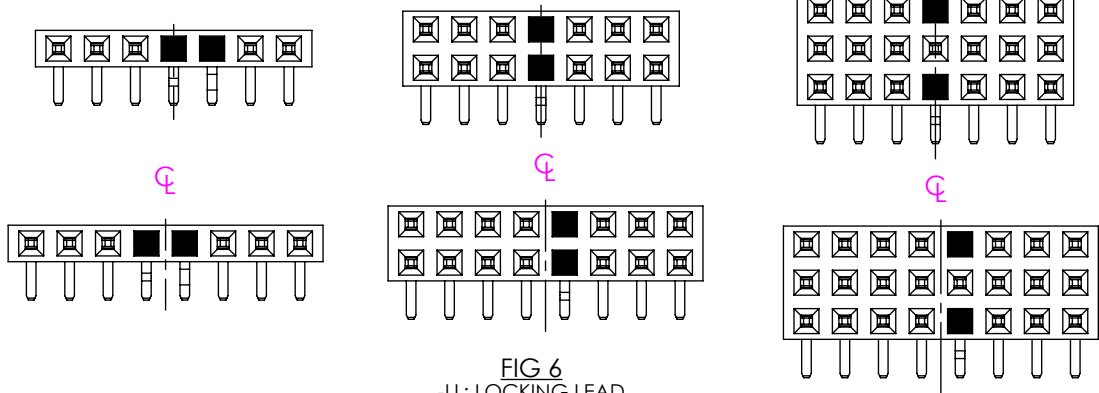

FIG 6
-LL: LOCKING LEAD
■ = CRIMP LOCATION
(DIFFERENT AS SHOWN,
OTHERWISE SAME AS FIG 1)

TABLE 3			
IN PROCESS	"D"	"E"	"F"
SSQ-1XX-02-X-D-RA	0.194 [4.93]	0.394 [10.01]	N/A
SSQ-1XX-03-X-D-RA	0.394 [10.01]	0.594 [15.09]	N/A
SSQ-1XX-02-X-T-RA	0.194 [4.93]	0.394 [10.01]	0.594 [15.09]

PROPRIETARY NOTE
THIS DOCUMENT CONTAINS CONFIDENTIAL AND PROPRIETARY INFORMATION AND ALL DESIGN, MANUFACTURING, REPRODUCTION, USE, PATENT RIGHTS AND SALES RIGHTS ARE EXPRESSLY RESERVED BY SAMTEC, INC. THIS DOCUMENT SHALL NOT BE DISCLOSED, IN WHOLE OR PART, TO ANY UNAUTHORIZED PERSON OR ENTITY NOR REPRODUCED, TRANSFERRED OR INCORPORATED IN ANY OTHER PROJECT IN ANY MANNER WITHOUT THE EXPRESS WRITTEN CONSENT OF SAMTEC, INC.

DO NOT SCALE DRAWING

SHEET SCALE: 2:1



DESCRIPTION:
ASSEMBLY, SOCKET STRIP .025[0.64] SQ TAIL

DWG. NO.
SSQ-1XX-XX-XXX-X-XX-XXX-XX-X

BY: PURVIS 06/12/1987 SHEET 2 OF 3

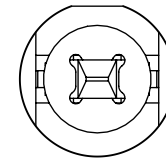
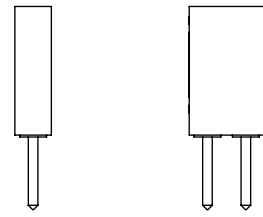
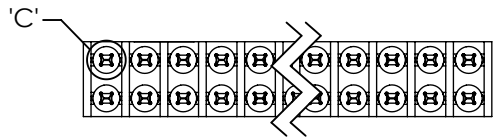
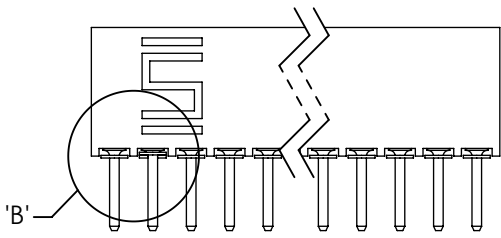

DETAIL 'C'
SCALE 8:1

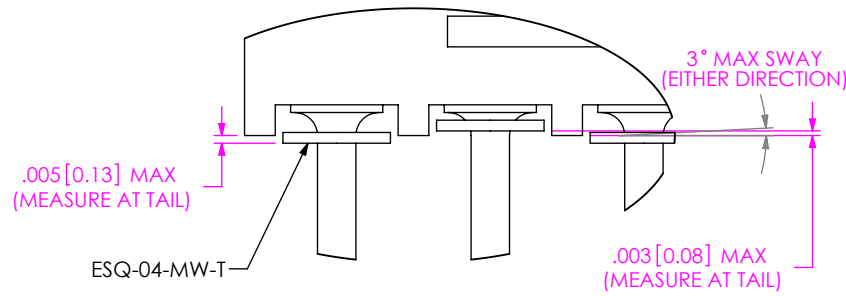

DETAIL 'B'
SCALE 8:1

FIG 7
SSQ-1XX-XXX-X-MW SHOWN
(DIFFERENT AS SHOWN,
OTHERWISE SAME AS FIG 1)
**-MW: METAL WASHER
(ONE PER POSITION)
(N/A ON -LL OR -RA OPTION OR TRIPLE ROW)
(STYLE -01, -02, -21 AND -22 ONLY)
(AVAILABLE ON POS -02 THRU -30 ONLY)
(DIFFERENT AS SHOWN, OTHERWISE SAME AS FIG 1)
** - MW OPTION, DO NOT DESIGN IN. SAMTEC WILL
ONLY SUPPORT EXISTING BUSINESS AS OF 02/12/2002

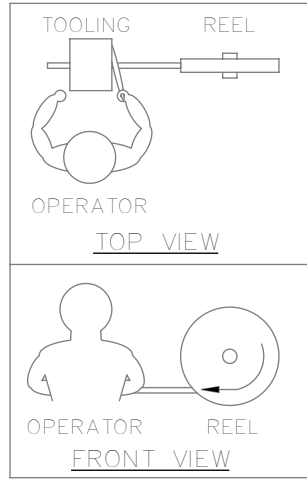

WASHER REEL ASSEMBLY
ORIENTATION VIEW

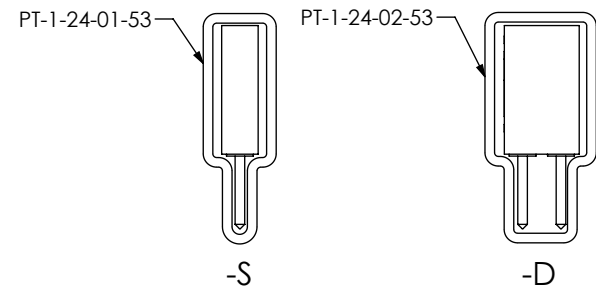

FIG 9
FOR METAL WASHERS ONLY
(ALL OTHER OPTIONS BULK PACKAGED)

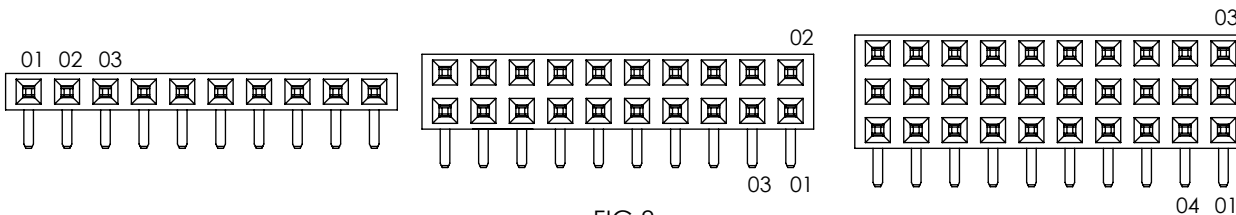

FIG 8
POLARIZATION LOCATION
INSERT PK-15-N INTO SPECIFIED POS
AND BREAK OFF TAB

PROPRIETARY NOTE
THIS DOCUMENT CONTAINS CONFIDENTIAL AND
PROPRIETARY INFORMATION AND ALL DESIGN,
MANUFACTURING, REPRODUCTION, USE, PATENT RIGHTS
AND SALES RIGHTS ARE EXPRESSLY RESERVED BY SAMTEC,
INC. THIS DOCUMENT SHALL NOT BE DISCLOSED, IN WHOLE
OR PART, TO ANY UNAUTHORIZED PERSON OR ENTITY NOR
REPRODUCED, TRANSFERRED OR INCORPORATED IN ANY
OTHER PROJECT IN ANY MANNER WITHOUT THE EXPRESS
WRITTEN CONSENT OF SAMTEC, INC.

DO NOT SCALE DRAWING

SHEET SCALE: 2:1



520 PARK EAST BLVD, NEW ALBANY, IN 47150
PHONE: 812-944-6733 FAX: 812-948-5047
e-Mail info@SAMTEC.com code 55322

DESCRIPTION:
ASSEMBLY, SOCKET STRIP .025[0.64] SQ TAIL

DWG. NO.
SSQ-1 XX-XX-XXX-X-XX-XXX-XX-X

BY: PURVIS 06/12/1987 SHEET 3 OF 3