

1. 製品名称／PRODUCT NAME : PICOBLADE 1.25 SMT R/A EMBOSSED TAPE PACKAGING  
 製品番号／PART NUMBER : 5 3 2 6 1 \* \* 2 7  
                                   5 3 2 6 1 \* \* 7 1 ( 5 3 2 6 1 1 7 7 1 は除く／532611771 is excluded)  
                                   5 3 2 6 1 4 0 \* \*  
                                   5 3 2 6 1 7 0 \* \*  
                                   ( \* \* は極数を示す。 )  
                                   ( \* \* SHOWS CIRCUITS SIZE. )

2. 標準梱包数／STANDARD PACK QUANTITY

極 数 CKT. SIZE	キャリア テープ幅 (mm) CARRIER TAPE WIDTH (mm)	1 リール中の製品数 QTY. PER REEL	外装カートン SHIPPING CARTON	
			梱包リール数 NUMBER OF REELS	製品数 QUANTITY
2	16	1,600	8	12,800
3				
4	24	1,600	6	9,600
5				
6				
7				
8				
9				
10				
11	32	1,600	5	8,000
12				
13				
14	44	1,600	4	6,400
15				

THIS DOCUMENT CONTAINS INFORMATION THAT IS PROPRIETARY TO MOLEX ELECTRONIC TECHNOLOGIES, LLC AND SHOULD NOT BE USED WITHOUT WRITTEN PERMISSION

REVISION DESCRIPTION	REVISED	<b>SALES PACKAGING SPEC. FOR 53261</b>					
CHANGE NO.	757246						
REVISED BY	YTOKUZONO	DATE	2022/05/27	DOC TYPE	DOC TYPE DESCRIPTION	DOC PART	SERIES
REV APPR BY	HSHIMOYAMA	DATE	2023/07/20	PS	ENGINEERING SPECIFICATION WORD	001	53261
INITIAL RELEASE				CUSTOMER	DOCUMENT NUMBER	REVISION	SHEET
INITIAL DRWN	YTOKUZONO	DATE	2009/06/30	GENERAL	<b>SPK-53261-002</b>	<b>H</b>	1 OF 2
INITIAL APPR	NUKITA	DATE	2009/07/01				

3. ハイバリア袋への梱包方法及びラベル貼付位置 / PACKAGING METHOD FOR HIGH BARRIER BAG AND LABEL POSITION

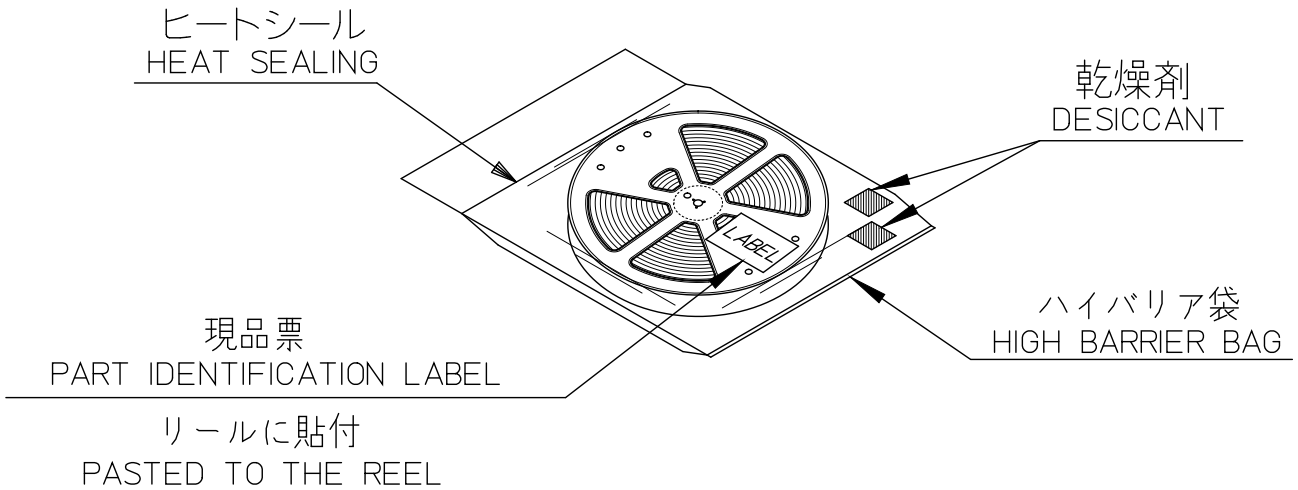

4. カートン外形参考寸法 / CARTON OUTER DIMENSIONS (REFERENCE PURPOSE ONLY) 単位 / UNIT: mm

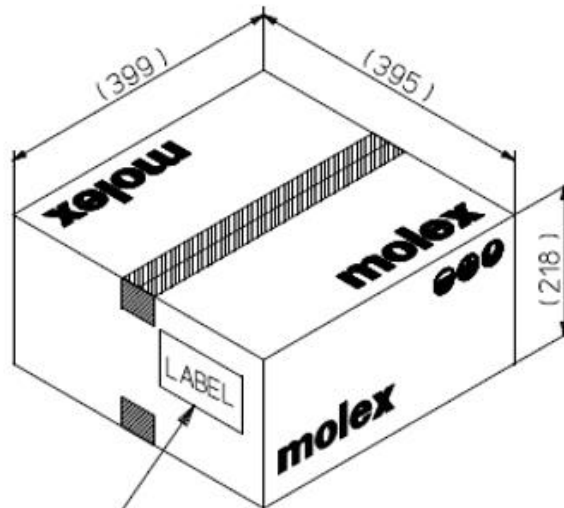

THIS DOCUMENT CONTAINS INFORMATION THAT IS PROPRIETARY TO MOLEX ELECTRONIC TECHNOLOGIES, LLC AND SHOULD NOT BE USED WITHOUT WRITTEN PERMISSION

REVISION DESCRIPTION	REVISED	<b>SALES PACKAGING SPEC. FOR 53261</b>					
CHANGE NO.	757246						
REVISED BY	YTOKUZONO	DATE	2022/05/27	DOC TYPE	DOC TYPE DESCRIPTION	DOC PART	SERIES
REV APPR BY	HSHIMOYAMA	DATE	2023/07/20	PS	ENGINEERING SPECIFICATION WORD	001	53261
INITIAL RELEASE				CUSTOMER	DOCUMENT NUMBER	REVISION	SHEET
INITIAL DRWN	YTOKUZONO	DATE	2009/06/30	GENERAL	<b>SPK-53261-002</b>	<b>H</b>	2 OF 2
INITIAL APPR	NUKITA	DATE	2009/07/01				