



MCT2M, MCT2EM, MCT210M, MCT271M Phototransistor Optocouplers

Features

- UL recognized (File # E90700, Vol. 2)
- IEC60747-5-2 recognized (File # 102497)
 - Add option V (e.g., MCT2VM)

Applications

- Power supply regulators
- Digital logic inputs
- Microprocessor inputs

Description

The MCT2XXM series optoisolators consist of a gallium arsenide infrared emitting diode driving a silicon phototransistor in a 6-pin dual in-line package.

Schematic

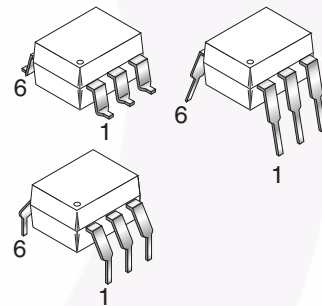
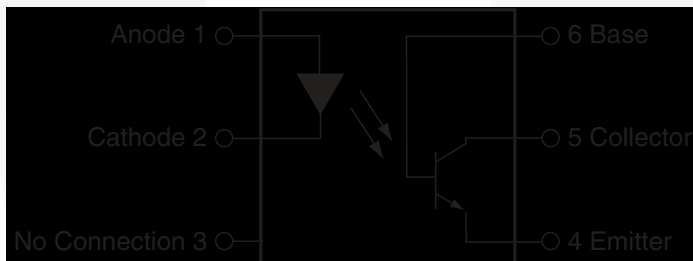

Absolute Maximum Ratings

Stresses exceeding the absolute maximum ratings may damage the device. The device may not function or be operable above the recommended operating conditions and stressing the parts to these levels is not recommended. In addition, extended exposure to stresses above the recommended operating conditions may affect device reliability. The absolute maximum ratings are stress ratings only.

Symbol	Parameter	Value	Units
TOTAL DEVICE			
T _{STG}	Storage Temperature	-40 to +150	°C
T _{OPR}	Operating Temperature	-40 to +100	°C
T _{SOL}	Lead Solder Temperature	260 for 10 sec	°C
P _D	Total Device Power Dissipation @ T _A = 25°C	250	mW
	Derate above 25°C	2.94	mW/°C
EMITTER			
I _F	DC/Average Forward Input Current	60	mA
V _R	Reverse Input Voltage	3	V
I _{F(pk)}	Forward Current – Peak (300µs, 2% Duty Cycle)	3	A
P _D	LED Power Dissipation @ T _A = 25°C	120	mW
	Derate above 25°C	1.41	mW/°C
DETECTOR			
I _C	Collector Current	50	mA
V _{CEO}	Collector-Emitter Voltage	30	V
P _D	Detector Power Dissipation @ T _A = 25°C	150	mW
	Derate above 25°C	1.76	mW/°C

Electrical Characteristics ($T_A = 25^\circ\text{C}$ unless otherwise specified)**Individual Component Characteristics**

Symbol	Parameter	Test Conditions	Device	Min.	Typ.*	Max.	Units
EMITTER							
V_F	Input Forward Voltage	$I_F = 20\text{mA}$	MCT2M MCT2EM MCT271M		1.25	1.50	V
		$T_A = 0^\circ\text{C} - 70^\circ\text{C}$, $I_F = 40\text{mA}$	MCT210M		1.33		
I_R	Reverse Leakage Current	$V_R = 3.0\text{V}$	MCT2M MCT2EM MCT271M		0.001	10	μA
		$T_A = 0^\circ\text{C} - 70^\circ\text{C}$, $V_R = 6.0\text{V}$	MCT210M				
DETECTOR							
BV_{CEO}	Collector-Emitter Breakdown Voltage	$I_C = 1.0\text{mA}$, $I_F = 0$	ALL	30	100		V
		$T_A = 0^\circ\text{C} - 70^\circ\text{C}$	MCT210M				
BV_{CBO}	Collector-Base Breakdown Voltage	$I_C = 10\mu\text{A}$, $I_F = 0$	MCT2M MCT2EM MCT271M	70	120		V
		$T_A = 0^\circ\text{C} - 70^\circ\text{C}$	MCT210M	30			
BV_{ECO}	Emitter-Collector Breakdown Voltage	$I_E = 100\mu\text{A}$, $I_F = 0$	MCT2M MCT2EM MCT271M	7	10		V
		$T_A = 0^\circ\text{C} - 70^\circ\text{C}$	MCT210M	6	10		
I_{CEO}	Collector-Emitter Dark Current	$V_{CE} = 10\text{V}$, $I_F = 0$	ALL		1	50	nA
		$V_{CE} = 5\text{V}$, $T_A = 0^\circ\text{C} - 70^\circ\text{C}$				30	μA
I_{CBO}	Collector-Base Dark Current	$V_{CB} = 10\text{V}$, $I_F = 0$	ALL			20	nA
C_{CE}	Capacitance	$V_{CE} = 0\text{V}$, $f = 1\text{MHz}$	ALL		8		pF

*All typical $T_A = 25^\circ\text{C}$ **Isolation Characteristics**

Symbol	Parameter	Test Conditions	Min	Typ*	Max	Units
V_{ISO}	Input-Output Isolation Voltage	$f = 60\text{Hz}$, $t = 1 \text{ sec.}$	7500			Vac(pk)
R_{ISO}	Isolation Resistance	$V_{I-O} = 500 \text{ VDC}$	10^{11}			Ω
C_{ISO}	Isolation Capacitance			0.2	2	pF

*All typicals at $T_A = 25^\circ\text{C}$

Electrical Characteristics (Continued) ($T_A = 25^\circ\text{C}$ unless otherwise specified)**Transfer Characteristics**

Symbol	Parameter	Test Conditions	Device	Min.	Typ.*	Max.	Unit
DC CHARACTERISTICS							
CTR	Output Collector Current	$T_A = 0^\circ\text{C} - 70^\circ\text{C}$	MCT210M	150			%
		$I_F = 10\text{mA}, V_{CE} = 10\text{V}$	MCT2M MCT2EM	20			
			MCT271M	45		90	
		$I_F = 3.2\text{mA to } 32\text{mA}, V_{CE} = 0.4\text{V}, T_A = 0^\circ\text{C} - 70^\circ\text{C}$	MCT210M	50			
$V_{CE(SAT)}$	Collector-Emitter Saturation Voltage	$I_C = 2\text{mA}, I_F = 16\text{mA}$	MCT2M MCT2EM MCT271M			0.4	V
		$I_C = 16\text{mA}, I_F = 32\text{mA}, T_A = 0^\circ\text{C} - 70^\circ\text{C}$	MCT210M				
AC CHARACTERISTICS							
t_{on}	AC Characteristic Saturated Turn-on Time from 5V to 0.8V	$I_F = 15\text{mA}, V_{CC} = 5\text{V}, R_L = 2\text{k}\Omega, R_B = \text{Open (Fig. 11)}$	MCT2M MCT2EM		1.1		μs
		$I_F = 20\text{mA}, V_{CC} = 5\text{V}, R_L = 2\text{k}\Omega, R_B = 100\text{k}\Omega \text{ (Fig. 11)}$	MCT2M MCT2EM		1.3		
t_{off}	Saturated Turn-off Time from SAT to 2.0 V	$I_F = 15\text{mA}, V_{CC} = 5\text{V}, R_L = 2\text{k}\Omega, R_B = \text{Open (Fig. 11)}$	MCT2M MCT2EM		50		μs
		$I_F = 20\text{mA}, V_{CC} = 5\text{V}, R_L = 2\text{k}\Omega, R_B = 100\text{k}\Omega \text{ (Fig. 11)}$	MCT2M MCT2EM		20		
t_{on}	Turn-on Time	$I_F = 10\text{mA}, V_{CC} = 10\text{V}, R_L = 100\Omega$	MCT2M MCT2EM		2		μs
t_{off}	Turn-off Time	$I_F = 10\text{mA}, V_{CC} = 10\text{V}, R_L = 100\Omega$	MCT2M MCT2EM		2		μs
t_r	Rise Time	$I_F = 10\text{mA}, V_{CC} = 10\text{V}, R_L = 100\Omega$	MCT2M MCT2EM		2		μs
t_f	Fall Time	$I_F = 10\text{mA}, V_{CC} = 10\text{V}, R_L = 100\Omega$	MCT2M MCT2EM		1.5		μs
t_{on}	Saturated turn-on time	$I_F = 16\text{mA}, R_L = 1.9\text{k}\Omega, V_{CC} = 5\text{V (Fig. 11)}$	MCT271M		1.0		μs
t_{off}	Saturated turn-off time (Approximates a typical TTL interface)				48		μs
t_{on}	Saturated turn-on time	$I_F = 16\text{mA}, R_L = 4.7\text{k}\Omega, V_{CC} = 5\text{V (Fig. 20)}$	MCT271M		1.0		μs
t_{off}	Saturated turn-off time (Approximates a typical low power TTL interface)				98		μs
t_r	Saturated rise time	$I_F = 16\text{mA}, R_L = 560\Omega, V_{CC} = 5\text{V (Fig. 11, 12)}$	MCT210M		1.0		μs
t_f	Saturated fall time				11		μs
$T_{PD(HL)}$	Saturated propagation delay – HIGH to LOW	$I_F = 16\text{mA}, R_L = 2.7\text{k}\Omega \text{ (Fig. 11, 12)}$	MCT210M		1.0		μs
$T_{PD(LH)}$	Saturated propagation delay – LOW to HIGH				50		μs
t_r	Non-saturated rise time	$I_C = 2\text{mA}, V_{CC} = 5\text{V}, R_L = 100\Omega \text{ (Fig. 11)}$	MCT210M		2		μs
t_f	Non-saturated fall time				2		μs
t_{on}	Non-saturated turn-on time	$I_C = 2\text{mA}, V_{CC} = 5\text{V}, R_L = 100\Omega \text{ (Fig. 20)}$	MCT271M		2	7	μs
t_{off}	Non-saturated turn-off time				2	7	μs

*All typicals at $T_A = 25^\circ\text{C}$

Typical Performance Curves

Fig. 1 LED Forward Voltage vs. Forward Current

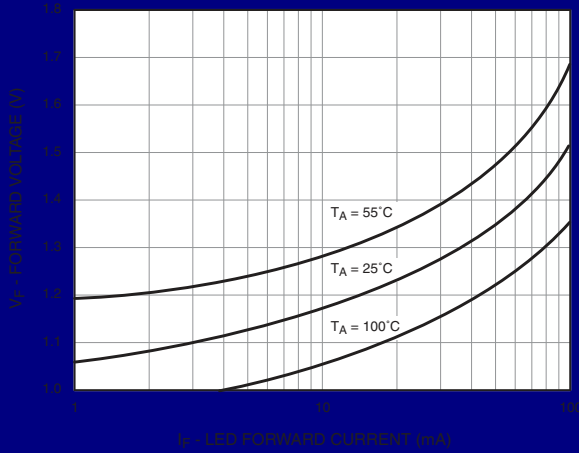

Fig. 2 Normalized CTR vs. Forward Current

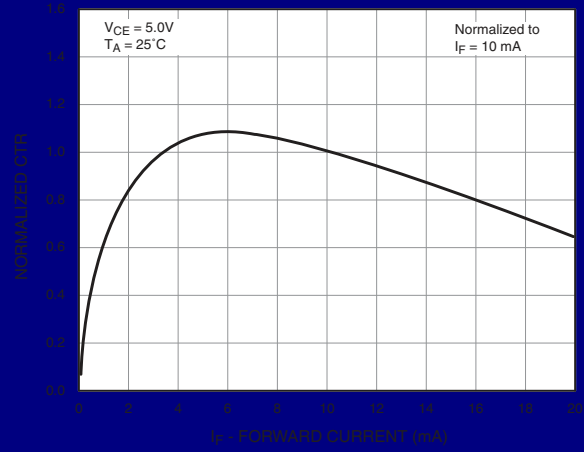

Fig. 3 Normalized CTR vs. Ambient Temperature

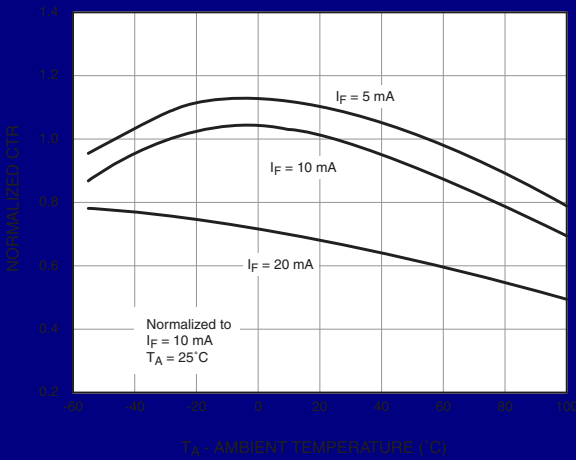

Fig. 4 CTR vs. RBE (Unsaturated)

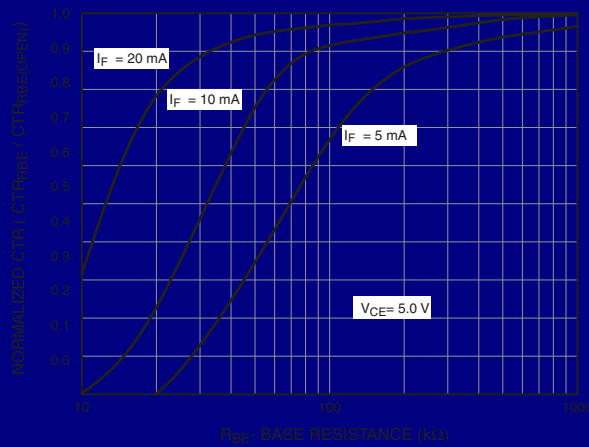

Fig. 5 CTR vs. RBE (Saturated)

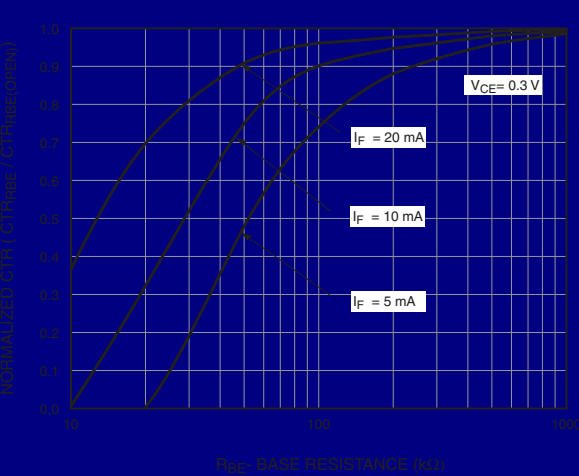
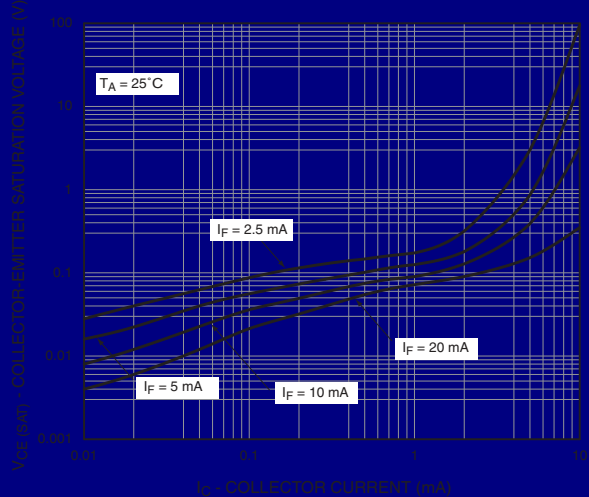
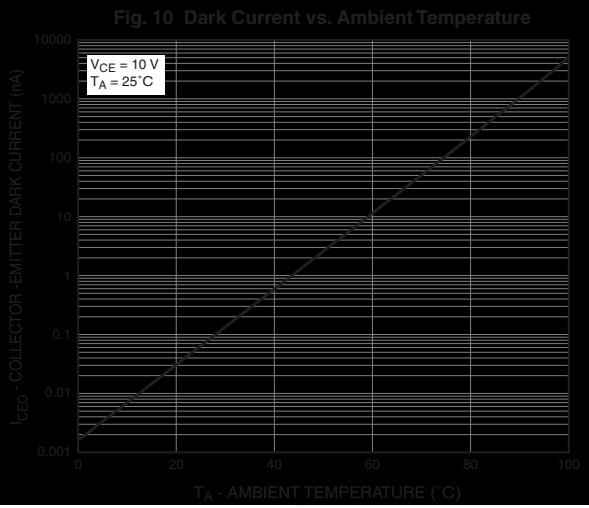
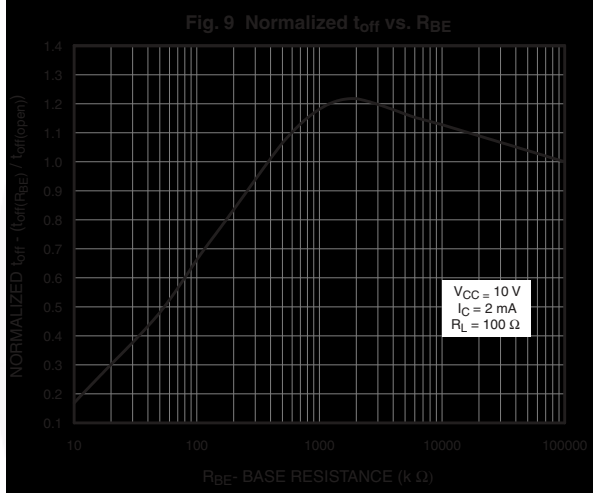
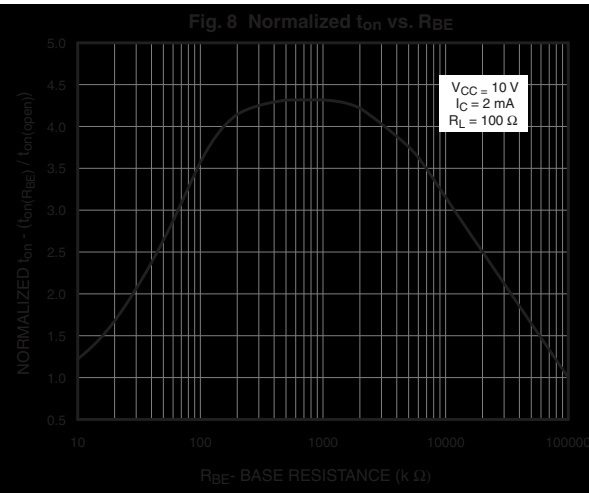
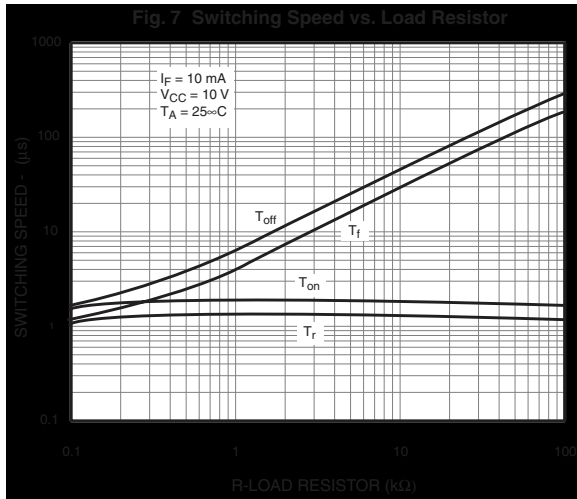

Fig. 6 Collector-Emitter Saturation Voltage vs. Collector Current



Typical Performance Curves (Continued)



Typical Electro-Optical Characteristics

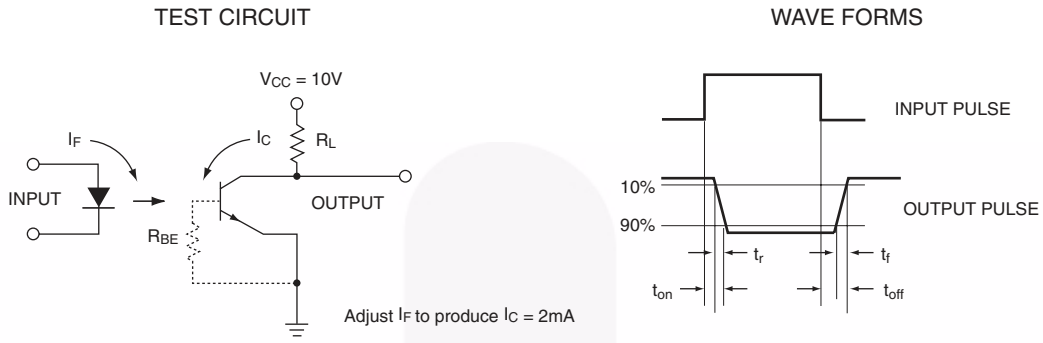

Figure 11. Switching Time Test Circuit and Waveforms

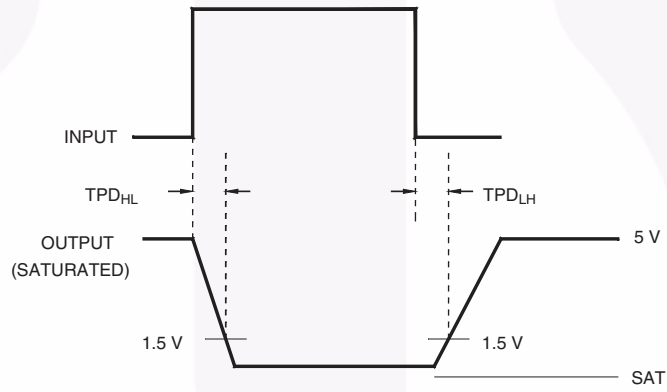
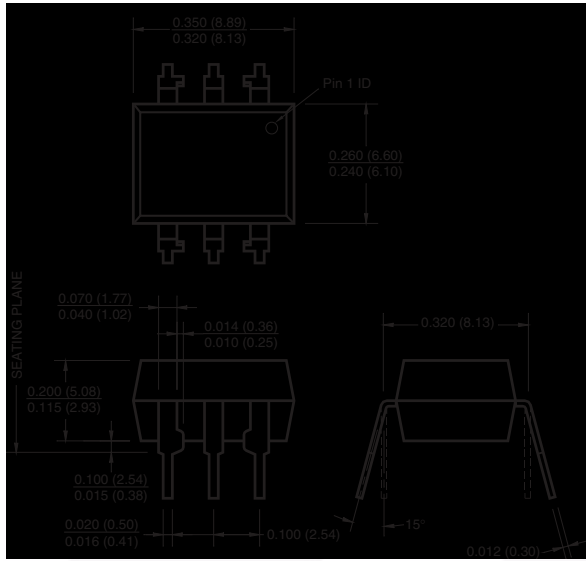

Figure 12. Switching Time Waveforms (MCT210M)

Package Dimensions

Through Hole



Surface Mount

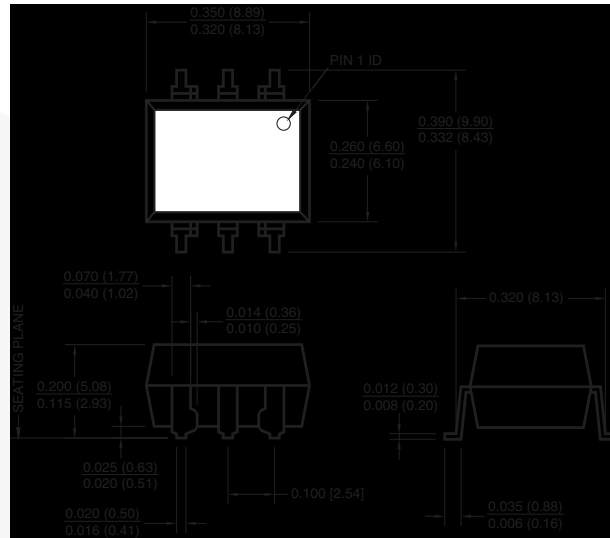

0.4" Lead Spacing

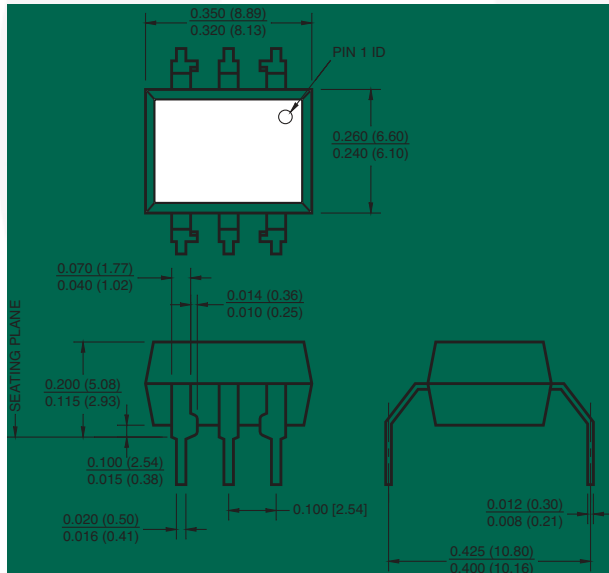

Recommended Pad Layout for Surface Mount Leadform

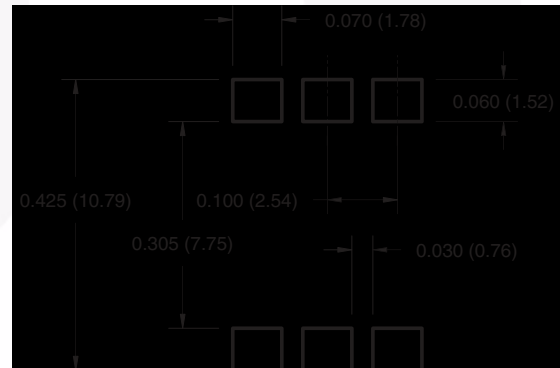

Note:

All dimensions are in inches (millimeters)

Ordering Information

Option	Order Entry Identifier (Example)	Description
No suffix	MCT2M	Standard Through Hole Device (50 units per tube)
S	MCT2SM	Surface Mount Lead Bend
SR2	MCT2SR2M	Surface Mount; Tape and Reel (1,000 units per reel)
T	MCT2TM	0.4" Lead Spacing
V	MCT2VM	IEC60747-5-2
TV	MCT2TVM	IEC60747-5-2, 0.4" Lead Spacing
SV	MCT2SVM	IEC60747-5-2, Surface Mount
SR2V	MCT2SR2VM	IEC60747-5-2, Surface Mount, Tape and Reel (1,000 units per reel)

Marking Information

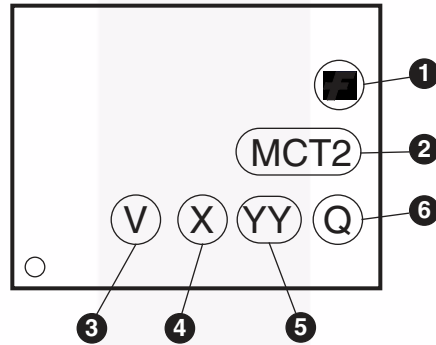

Definitions	
1	Fairchild logo
2	Device number
3	VDE mark (Note: Only appears on parts ordered with VDE option – See order entry table)
4	One digit year code, e.g., '7'
5	Two digit work week ranging from '01' to '53'
6	Assembly package code

*Note – Parts that do not have the 'V' option (see definition 3 above) that are marked with date code '325' or earlier are marked in portrait format.

Carrier Tape Specification

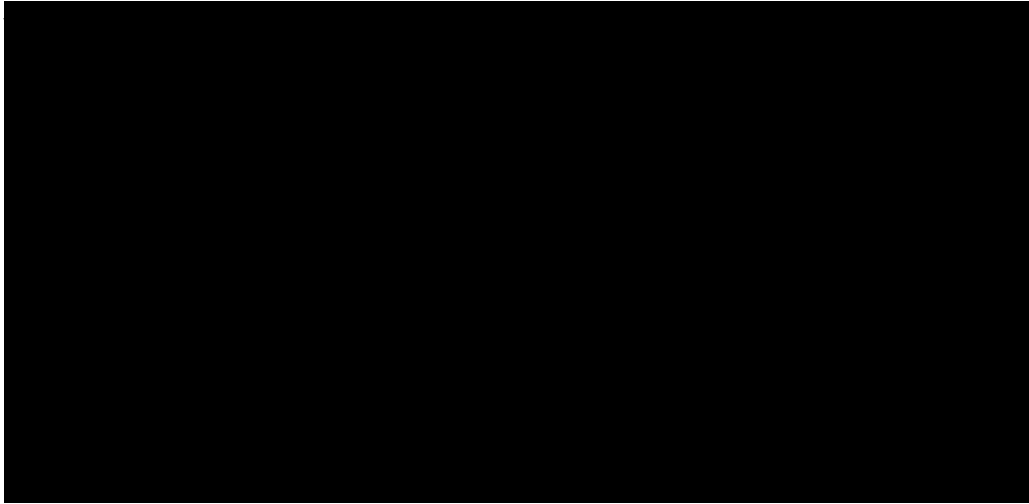

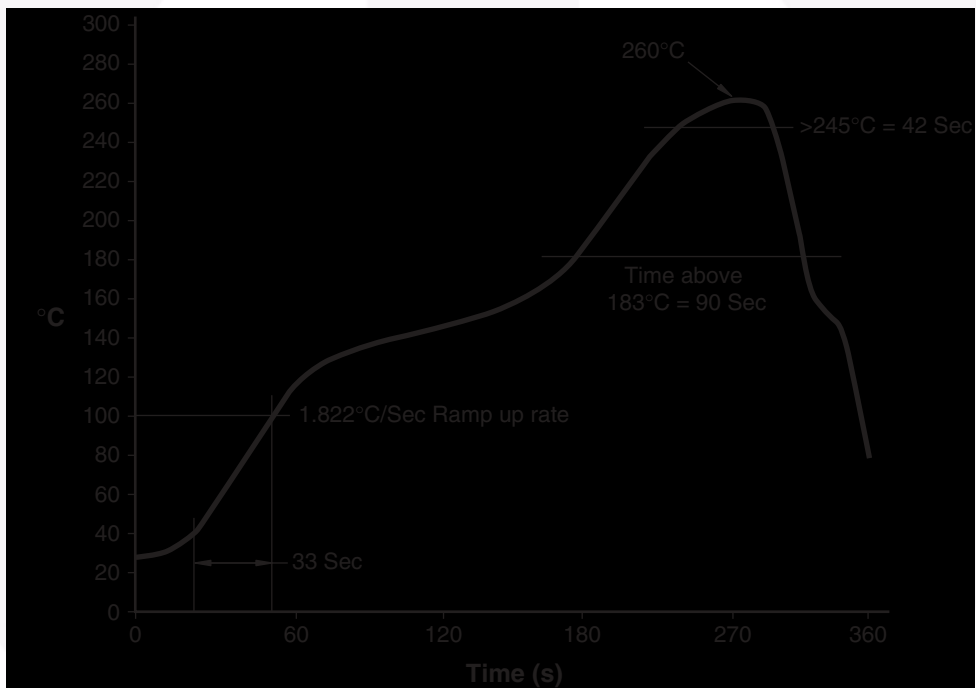

Reflow Profile





subsidiaries, and is not intended to be an exhaustive list of all such trademarks.

ACE [®]	FPS [™]	PDP-SPM [™]	SupreMOS [™]
Build it Now [™]	FRFET [®]	Power220 [®]	SyncFET [™]
CorePLUS [™]	Global Power Resource SM	POWEREDGE [®]	SYSTEM [®]
CROSSVOLT [™]	Green FPS [™]	Power-SPM [™]	GENERAL
CTL [™]	Green FPS [™] e-Series [™]	PowerTrench [®]	The Power Franchise [®]
Current Transfer Logic [™]	GTO [™]	Programmable Active Droop [™]	the
EcoSPARK [®]	i-Lo [™]	QFET [®]	power
EZSWITCH [™] *	IntelliMAX [™]	QS [™]	franchise
	ISOPLANAR [™]	QT Optoelectronics [™]	TinyBoost [™]
	MegaBuck [™]	Quiet Series [™]	TinyBuck [™]
Fairchild [®]	MICROCOUPLER [™]	RapidConfigure [™]	TinyLogic [®]
Fairchild Semiconductor [®]	MicroFET [™]	SMART START [™]	TINYOPTO [™]
FACT Quiet Series [™]	MicroPak [™]	SPM [®]	TinyPower [™]
FACT [®]	MillerDrive [™]	STEALTH [™]	TinyPWM [™]
FAST [®]	Motion-SPM [™]	SuperFET [™]	TinyWire [™]
FastvCore [™] *	OPTOLOGIC [®]	SuperSOT [™] 3	SerDes [™]
FlashWriter [®] *	OPTOPLANAR [®]	SuperSOT [™] 6	UHC [®]
		SuperSOT [™] 8	Ultra FRFET [™]
			UniFET [™]
			VCX [™]

* EZSWITCH[™] and FlashWriter[®] are trademarks of System General Corporation, used under license by Fairchild Semiconductor.

DISCLAIMER

FAIRCHILD SEMICONDUCTOR RESERVES THE RIGHT TO MAKE CHANGES WITHOUT FURTHER NOTICE TO ANY PRODUCTS HEREIN TO IMPROVE RELIABILITY, FUNCTION, OR DESIGN. FAIRCHILD DOES NOT ASSUME ANY LIABILITY ARISING OUT OF THE APPLICATION OR USE OF ANY PRODUCT OR CIRCUIT DESCRIBED HEREIN; NEITHER DOES IT CONVEY ANY LICENSE UNDER ITS PATENT RIGHTS, NOR THE RIGHTS OF OTHERS. THESE SPECIFICATIONS DO NOT EXPAND THE TERMS OF FAIRCHILD'S WORLDWIDE TERMS AND CONDITIONS, SPECIFICALLY THE WARRANTY THEREIN, WHICH COVERS THESE PRODUCTS.

LIFE SUPPORT POLICY

FAIRCHILD'S PRODUCTS ARE NOT AUTHORIZED FOR USE AS CRITICAL COMPONENTS IN LIFE SUPPORT DEVICES OR SYSTEMS WITHOUT THE EXPRESS WRITTEN APPROVAL OF FAIRCHILD SEMICONDUCTOR CORPORATION.

As used herein:

1. Life support devices or systems are devices or systems which, (a) are intended for surgical implant into the body or (b) support or sustain life, and (c) whose failure to perform when properly used in accordance with instructions for use provided in the labeling, can be reasonably expected to result in a significant injury of the user.
2. A critical component in any component of a life support, device, or system whose failure to perform can be reasonably expected to cause the failure of the life support device or system, or to affect its safety or effectiveness.

PRODUCT STATUS DEFINITIONS

Definition of Terms

Datasheet Identification	Product Status	Definition
Advance Information	Formative or In Design	This datasheet contains the design specifications for product development. Specifications may change in any manner without notice.
Preliminary	First Production	This datasheet contains preliminary data; supplementary data will be published at a later date. Fairchild Semiconductor reserves the right to make changes at any time without notice to improve design.