

THIS DRAWING IS UNPUBLISHED. RELEASED FOR PUBLICATION 20
 © COPYRIGHT 20 BY - ALL RIGHTS RESERVED.

REVISIONS				
P	LTR	DESCRIPTION	DATE	APVD
	A	INITIAL RELEASE	19FEB2015	LL SH

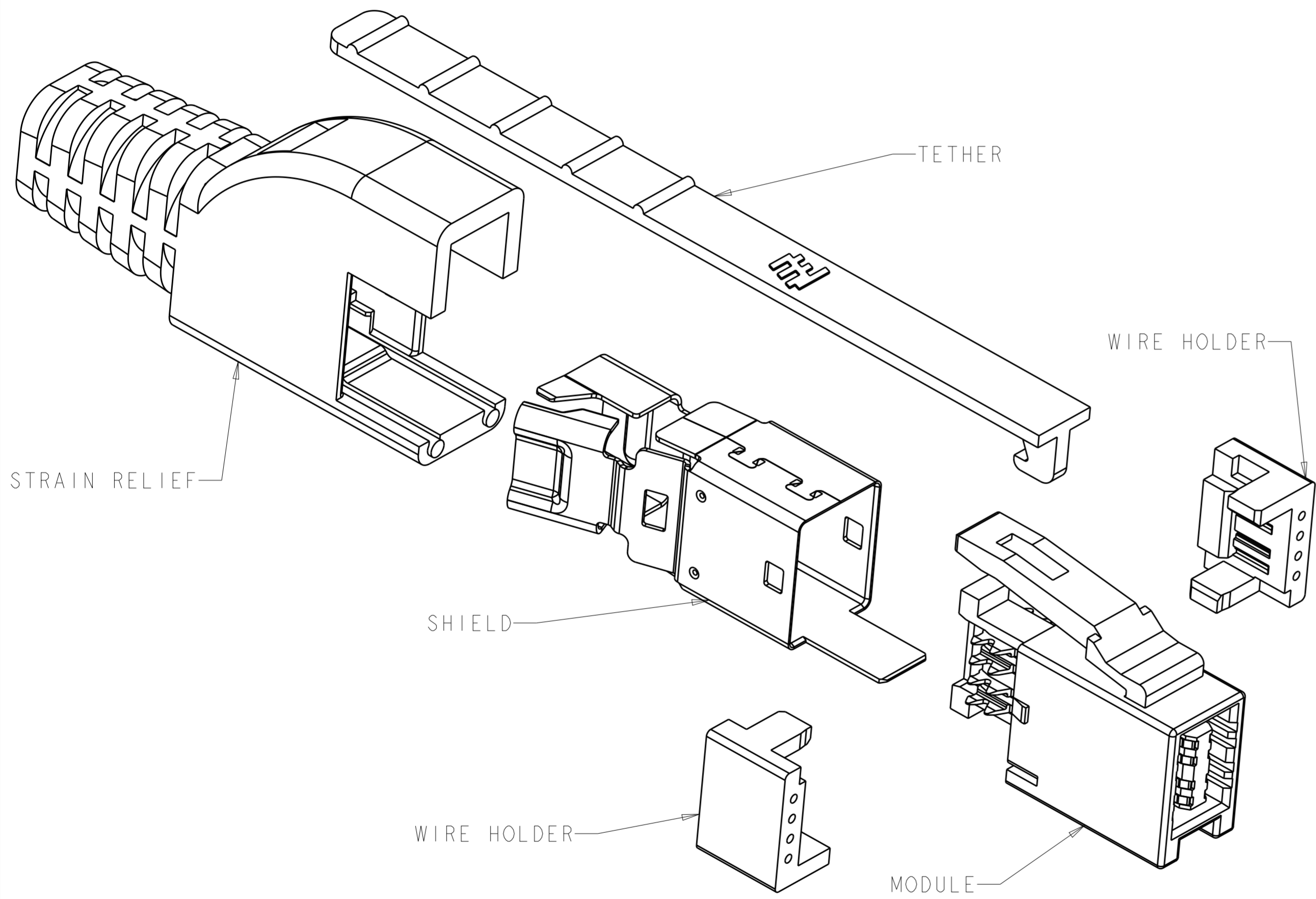

- 1. MATERIAL :
 MODULE HOUSING AND COVERS: POLYCARBONATE, CLEAR.
 MODULE CONTACTS: BRASS WITH 0.076µm MIN GOLD OVER
 0.68µm PALLADIUM-NICKEL ON MATING INTERFACE
 OVER 1.27µm MIN NICKEL.
 SHIELD: PRE-PLATED STAINLESS STEEL, 0.5µm MIN TIN ON
 SOLDERING AREA OVER 1.27µm MIN NICKEL PLATING OVER ALL
 STRAIN RELIEF: ELASTOMER POLYOLEFIN.
 LIGHTPIPE: POLYCARBONATE, CLEAR.
 TETHER: NYLON 6/6.
- 2. PRODUCT FOR USE WITH QUABBIN CABLE P/N 5400 OR
 OTHER CAT5e QUALIFIED CABLE WITH THE FOLLOWING
 MECHANICAL CONSTRAINTS:
 CABLE WITH METAL BRAIDED LAYER(STP)
 CENTER CONDUCTOR- 26 AWG STRANDED
 PRIMARY INSULATION DIAMETER 0.89 TO 0.99mm
 MAX JACKET O.D. - 5.70MM
- 3. REFER TO APPLICATION SPECIFICATION 114-13235 FOR
 COMPLETE ASSEMBLY INSTRUCTIONS
- 4. PRODUCT TO BE TERMINATED USING HAND TOOL
 P/N 2031734-1
- 5. BULK PACKAGING

5	2170347-1	2170347-2
1	1	2170347-1
QTY PER KIT	MATERIAL	PART NUMBER

THIS DRAWING IS A CONTROLLED DOCUMENT.		DWN DAVID SHEN 11MAY2012	STE TE Connectivity	
		CHK ALEX SHOAL 11MAY2012		
		APVD MANQIAN WANG 11MAY2012	NAME SHIELDED PLUG KIT	
DIMENSIONS: mm		PRODUCT SPEC 108-60097	RJ POINT FIVE	
TOLERANCES UNLESS OTHERWISE SPECIFIED:		APPLICATION SPEC 114-13235	SIZE A2	CAGE CODE 00779
0 PLC ±		WEIGHT -	DRAWING NO C-2170347	RESTRICTED TO -
1 PLC ±				
2 PLC ±				
3 PLC ±				
4 PLC ±				
ANGLES ±				
FINISH				
MATERIAL 1	finish_spec_2	CUSTOMER DRAWING		SCALE 1:1 SHEET 1 OF 2 REV A

THIS DRAWING IS UNPUBLISHED. RELEASED FOR PUBLICATION 20
 © COPYRIGHT 20 BY - ALL RIGHTS RESERVED.

REVISIONS				
P	LTR	DESCRIPTION	DATE	APVD
-		SEE SHEET 1	-	-

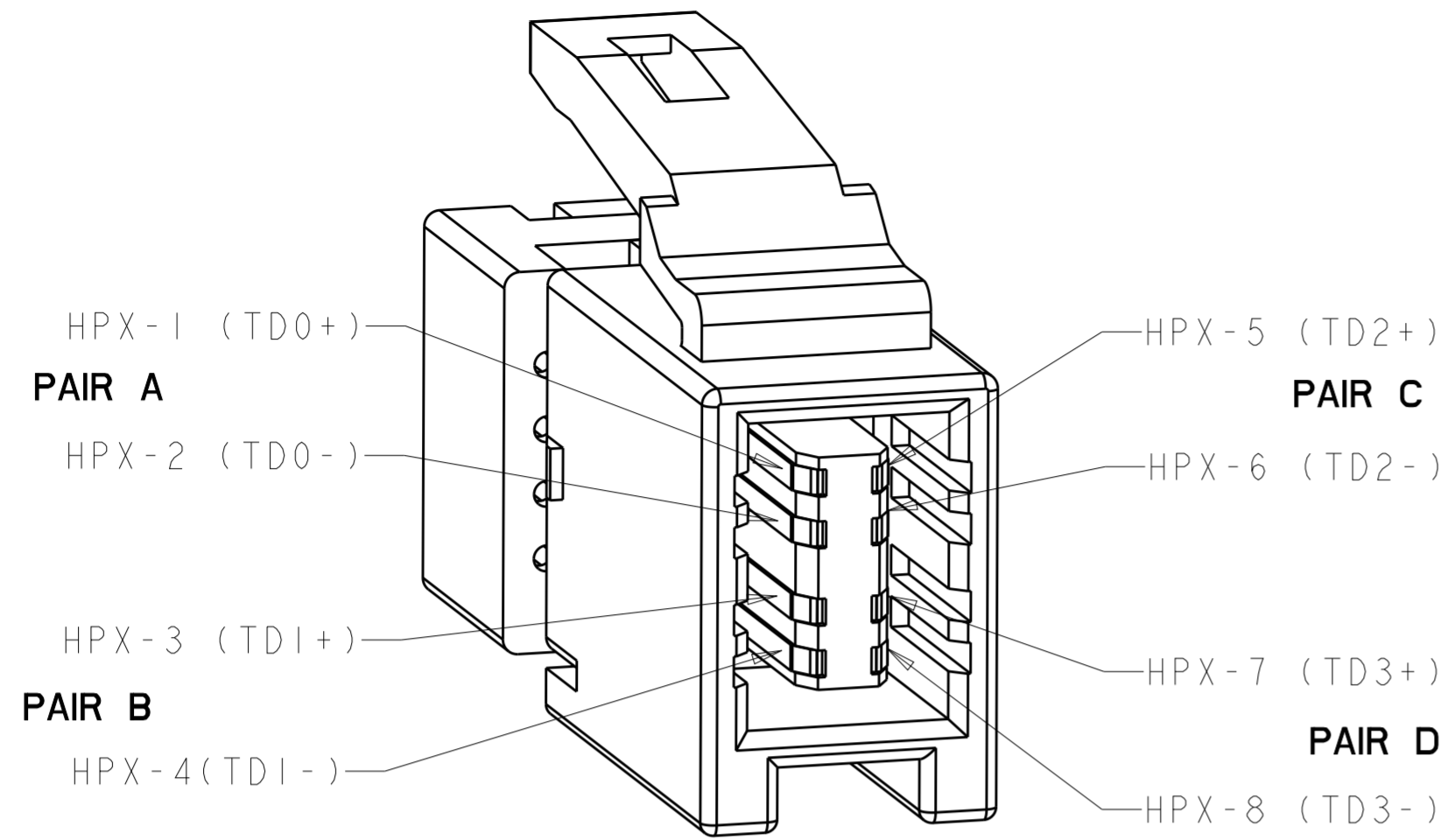

FIGURE 1
 SCALE 8:1

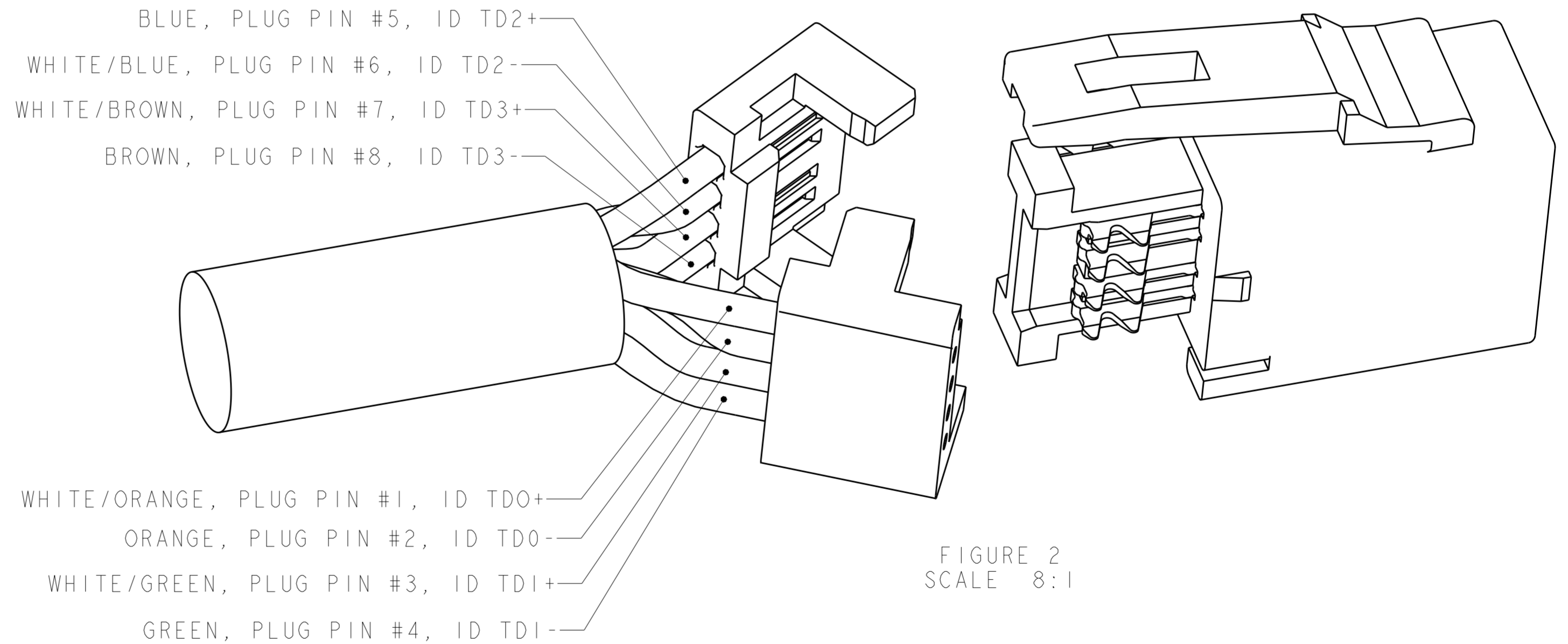

FIGURE 2
 SCALE 8:1

THIS DRAWING IS A CONTROLLED DOCUMENT.		DWN DAVID SHEN 11MAY2012	STE TE Connectivity	
		CHK ALEX SHOAL 11MAY2012		
		APVD MANLIAN WANG 11MAY2012	NAME SHIELDED PLUG KIT	
		PRODUCT SPEC	RJ POINT FIVE	
		APPLICATION SPEC	-	
		114-13235	SIZE	RESTRICTED TO
		WEIGHT	A200779	-
		CUSTOMER DRAWING	CAGE CODE	DRAWING NO
			G-2170347	
			SCALE 1:1	SHEET 2 OF 2
				REV A