

QUAD PRECISION MICROWATT CMOS VOLTAGE COMPARATOR WITH DRIVER

GENERAL DESCRIPTION

The ALD4303A/ALD4303 is a precision monolithic high performance quad voltage comparator with open drain output built with advanced silicon gate CMOS technology. It features very high typical input impedance of $10^{12}\Omega$; low input bias current of 10pA; very low power dissipation of 7.5µA per comparator; micropower operation; high output drive and single (+5V) or dual ($\pm 5V$) power supply operation.

The input voltage range includes ground, making this comparator ideal for single supply low level signal detection with high source impedance. The ALD4303A/ALD4303 can be used in connection with other voltage comparator circuits such as the ALD2301, ALD2302, and ALD4302 voltage comparators. The outputs can be connected to a higher external voltage than V+ and used in a wired-OR connection with other open drain circuits such as the ALD2301 and ALD2303. They can also be used with push-pull output types such as the ALD2302 and ALD4302 voltage comparators simultaneously with open drain comparators using a common V+. The ALD4303A/ALD4303 is ideal for a great variety of voltage comparator applications, especially micropower detection circuits requiring very low input currents, high output currents and low standby power.

FEATURES

- 3V, 5V and 10V supply
- Guaranteed to drive 200Ω loads
- Fanout of 30LS TTL loads
- Guaranteed maximum supply current of 22µA per comparator
- Industry standard pinout of LM393 type
- Extremely low input bias currents -- typically 10pA
- Virtually eliminates source impedance effects
- Single (+5V) and dual supply ($\pm 5V$) operation
- CMOS, NMOS and TTL compatible
- Open drain wired-OR outputs
- Compatible with push-pull outputs
- High output sinking current -- typically 60mA
- Low supply current spikes
- High gain -- 100V/mV

ORDERING INFORMATION ("L" suffix for lead free version)

Operating Temperature Range *		
0°C to +70°C	0°C to +70°C	-55°C to +125°C
14-Pin Small Outline Package (SOIC)	14-Pin Plastic Dip Package	14-Pin CERDIP Package
ALD4303ASBL ALD4303SBL	ALD4303APBL ALD4303PBL	ALD4303ADB ALD4303DB

* Contact factory for leaded (non-RoHS) or high temperature versions.

APPLICATIONS

- Sensor detection circuits
- PCMCIA instruments
- MOSFET driver
- High source impedance voltage comparison circuits
- Multiple limit window comparator
- Power supply voltage monitor
- Photodetector sensor circuit
- High speed LED driver
- Oscillators
- Battery operated instruments
- Remote signal detection
- Multiple relay drivers

PIN CONFIGURATION

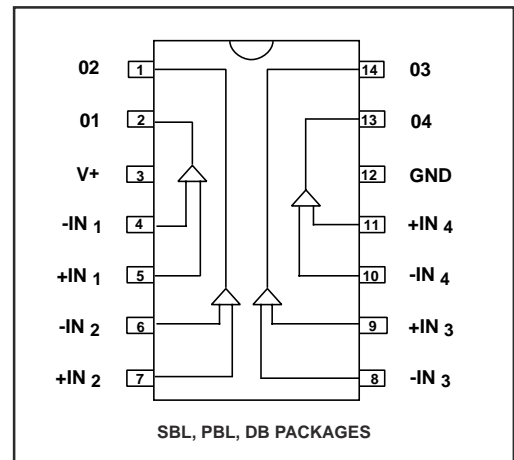

BLOCK DIAGRAM

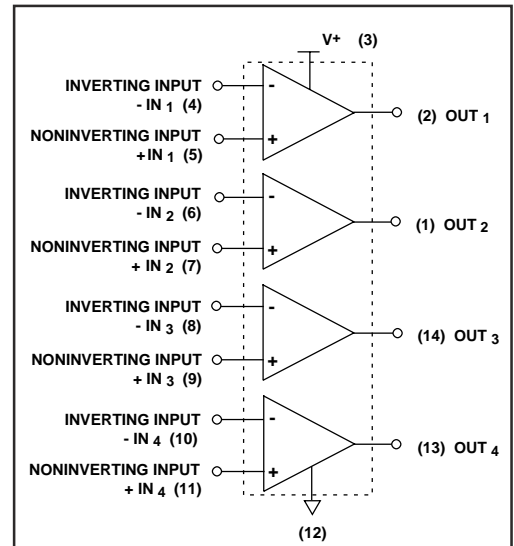

ABSOLUTE MAXIMUM RATINGS

Supply voltage, V+	_____	10.6V
Differential input voltage range	_____	-0.3V to V+ +0.3V
Power dissipation	_____	600 mW
Operating temperature range	SBL, PBL packages _____	0°C to +70°C
	DB package _____	-55°C to +125°C
Storage temperature range	_____	-65°C to +150°C
Lead temperature, 10 seconds	_____	+260°C

OPERATING ELECTRICAL CHARACTERISTICS

T_A = 25°C V_{+/-} = +5V unless otherwise specified

Parameter	Symbol	4303A			4303			Unit	Test Conditions
		Min	Typ	Max	Min	Typ	Max		
Supply Voltage	V _S V+	±1.5 3		±5 10	±1.5 3		±5 10	V V	Dual Supply Single Supply
Supply Current	I _S		50	90		50	90	μA	R _{LOAD} = ∞ 4 comparators
Voltage Gain	A _{VD}	10	100		10	100		V/mV	R _{LOAD} ≥ 15KΩ
Input Offset Voltage	V _{OS}		2	5.0 7.0		4	10.0 12.0	mV	R _{LOAD} = 1.5KΩ 0°C ≤ T _A ≤ 70°C
Input Offset Current ¹	I _{OS}		0.1	30 800		0.1	30 800	pA	0°C ≤ T _A ≤ 70°C
Input Bias Current ¹	I _B		0.1	30 1000		0.1	30 1000	pA	0°C ≤ T _A ≤ 70°C
Common Mode Input Voltage Range ²	V _{ICR}	-0.3		V+ -1.5	-0.3		V+ -1.5	V	
Low Level Output Voltage	V _{OL}		0.18	0.4		0.18	0.4	V	I _{SINK} = 12mA V _{INPUT} = 1V Differential
Low Level Output Current	I _{OL}	24	60		24	60		mA	V _{OL} = 1.0V
High Level Leakage Current	I _{LH}		0.1	20		0.1	20	nA	V _{OH} = 5.0V
Response Time ²	t _{RP}		6.5			6.5		μs	R _L = 50KΩ C _L = 15pF 10mV Input Step/10mV Overdrive
			5			5		μs	R _L = 50KΩ C _L = 15pF TTL- Level Input Step

Notes: ¹ Consists of junction leakage currents

² Sample tested parameters

TYPICAL PERFORMANCE CHARACTERISTICS

SATURATION VOLTAGE vs. TEMPERATURE

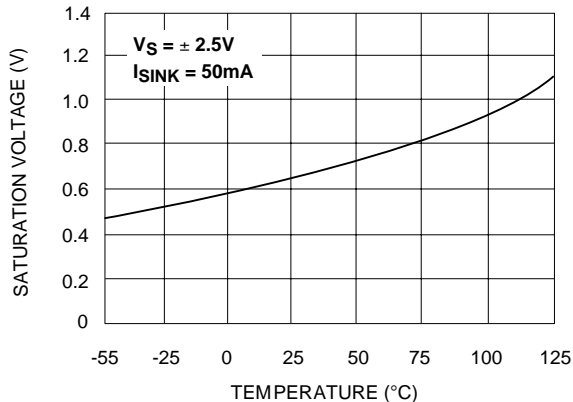

TRANSFER FUNCTION

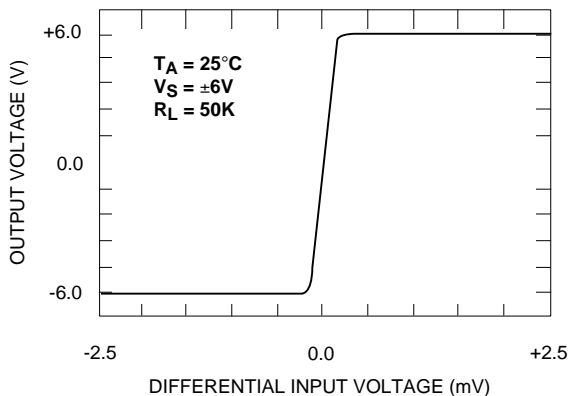

COMMON - MODE VOLTAGE REFERRED TO SUPPLY VOLTAGE

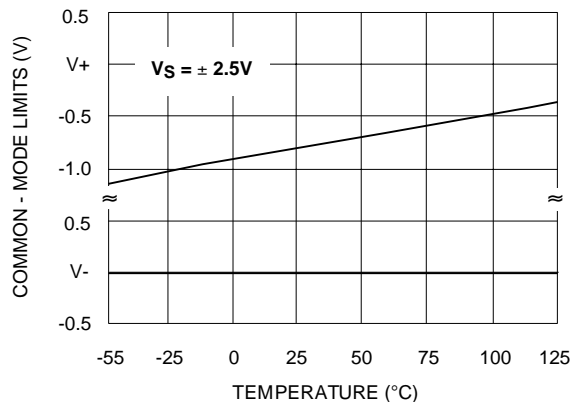

RESPONSE TIME FOR VARIOUS INPUT OVERDRIVES

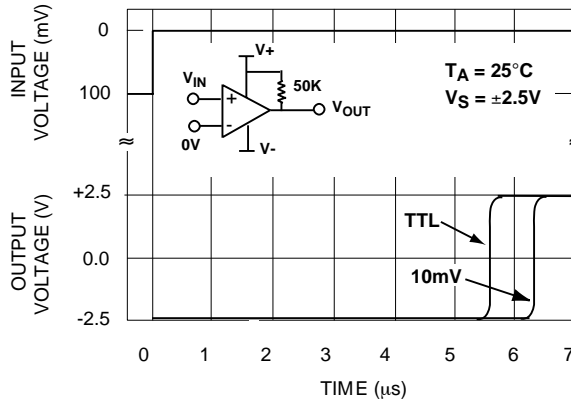

SATURATION VOLTAGE vs. SINK CURRENT

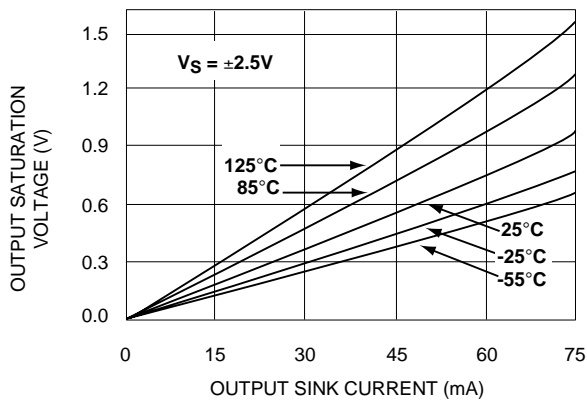

RESPONSE TIME FOR VARIOUS INPUT OVERDRIVES

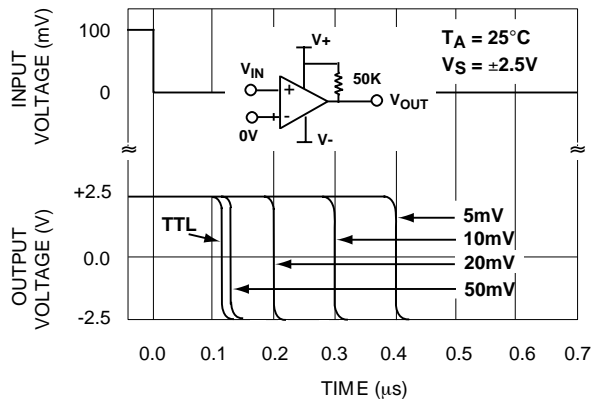

TYPICAL PERFORMANCE CHARACTERISTICS (cont'd)

TOTAL SUPPLY CURRENT vs. TOTAL SUPPLY VOLTAGE

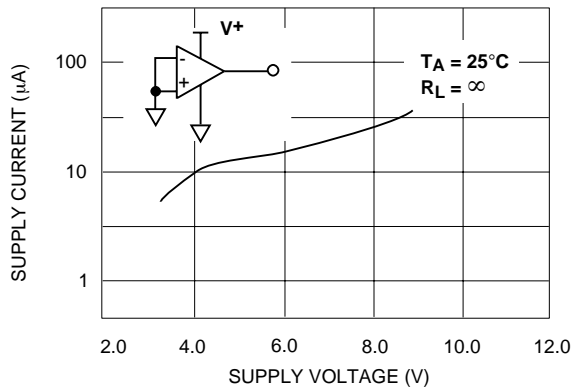

RESPONSE TIME FOR REPRESENTATIVE SAMPLES

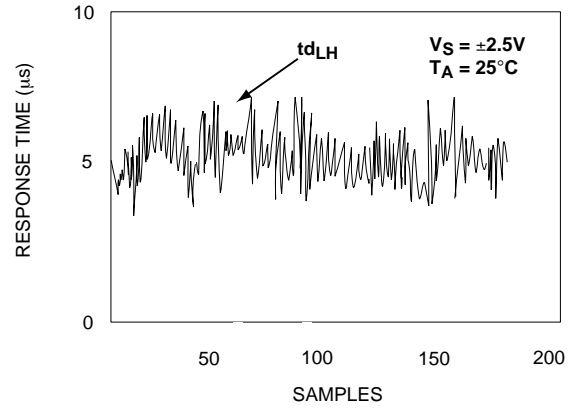

NORMALIZED INPUT OFFSET VOLTAGE vs. TEMPERATURE

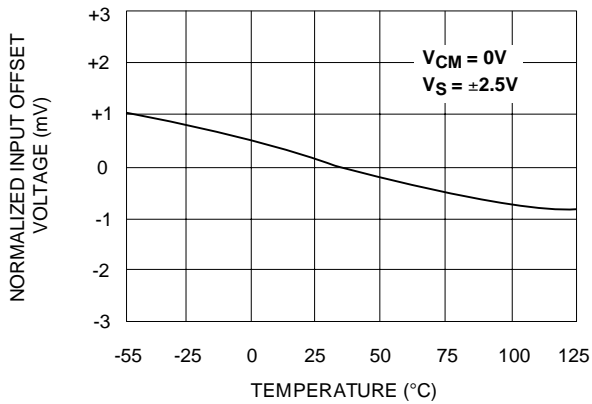

INPUT OFFSET VOLTAGE vs. SUPPLY VOLTAGE REPRESENTATIVE SAMPLES

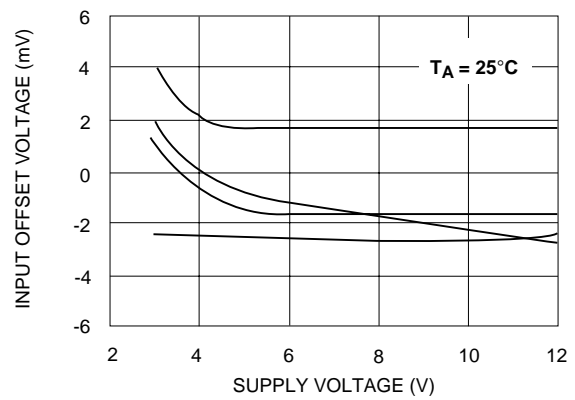

RESPONSE TIME FOR REPRESENTATIVE SAMPLES

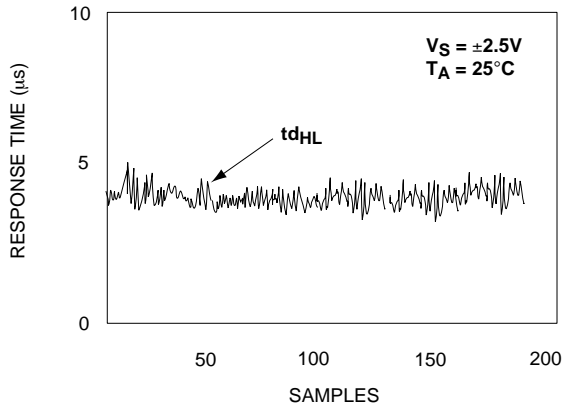

OUTPUT LOW VOLTAGE vs. SUPPLY VOLTAGE

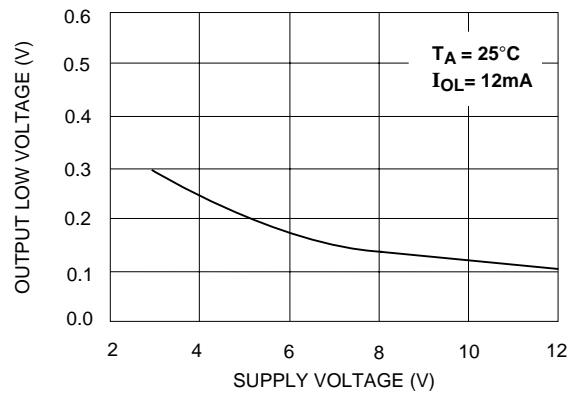

TYPICAL APPLICATIONS

ZERO CROSSING DETECTOR

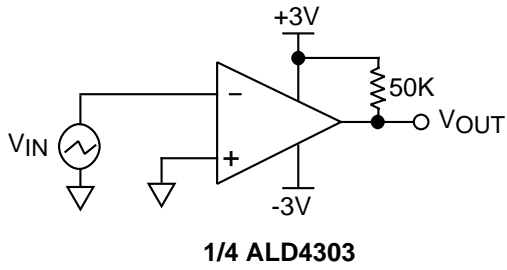

MULTIPLE RELAY DRIVE

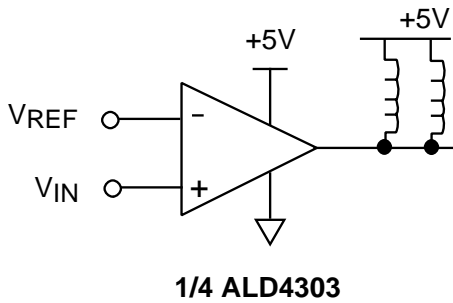

VOLTAGE LEVEL TRANSLATOR

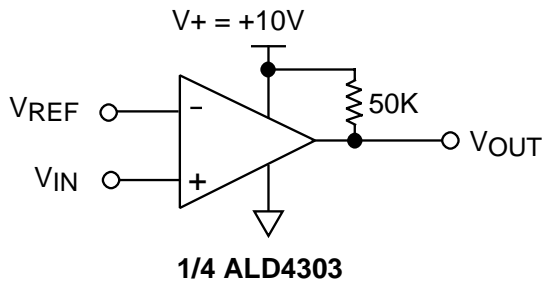

$V_{REF} = 1.4V$ for TTL input

$V_{REF} = \frac{V^+}{2}$ for CMOS input

Output V_{OUT} swings from rail-to-rail

DOUBLE QUAD LIMIT WINDOW COMPARATOR

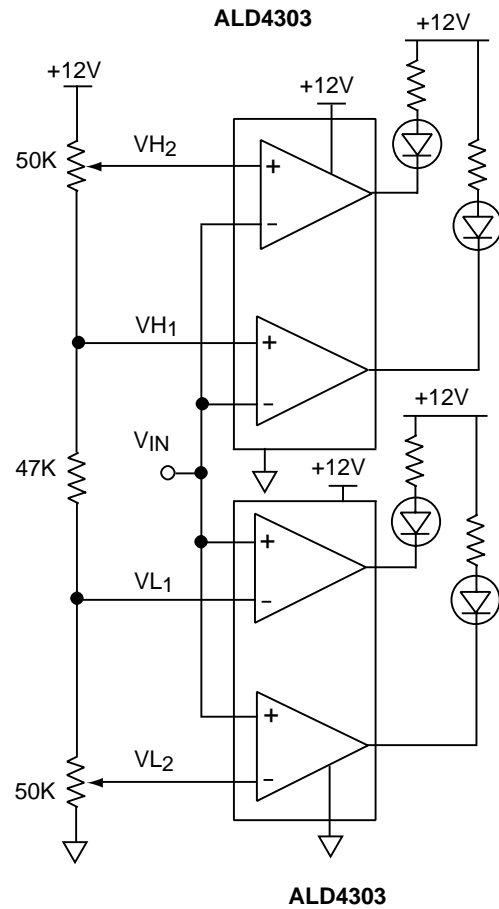

VL₁ and VH₁ first limit window send warning.
VL₂ and VH₂ second limit window execute system cutoff.

TYPICAL APPLICATIONS (cont'd)

PUSH-PULL COMPLEMENTARY POWER MOSFET DRIVER

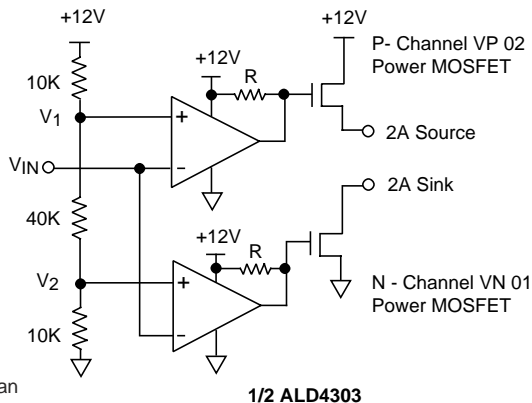

$R \geq 50 \text{ K}\Omega$

This circuit eliminates crossover current in the complementary power transistors. The outputs can be used to source and sink different loads or tied together to provide push-pull drive of the same load.

TIME DELAY GENERATOR

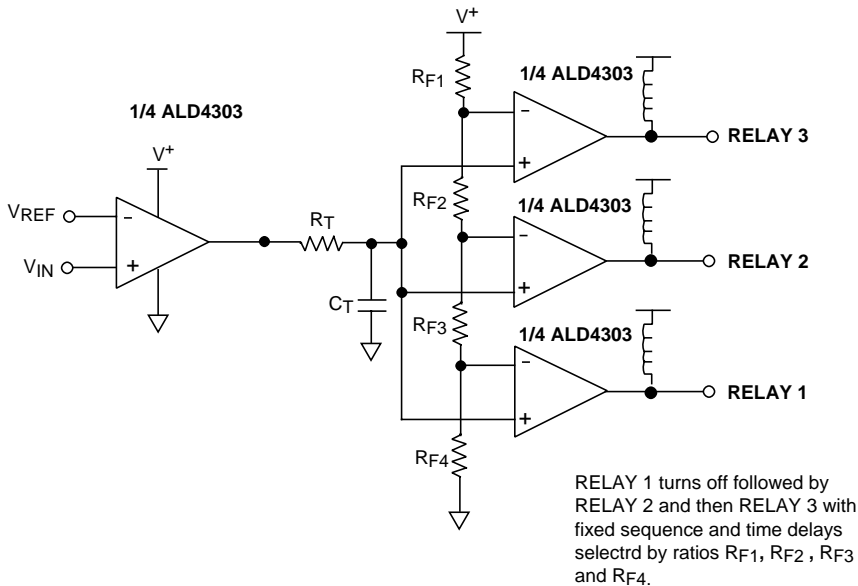

RELAY 1 turns off followed by RELAY 2 and then RELAY 3 with fixed sequence and time delays selected by ratios R_{F1} , R_{F2} , R_{F3} and R_{F4} .

Design & Operating Notes:

1. In order to minimize stray oscillation, all unused inputs must be tied to ground.
2. The input bias and offset currents are essentially input protection diode reverse bias leakage currents, and are typically less than 1pA at room temperature. These currents are a function of ambient temperature, and would have to be considered in applications where very high source impedance or high accuracy are involved.
3. The high output sinking current of 60mA for each output offers flexibility in many applications, as a separate buffer or driver would not be necessary to drive the intended load. However, as the circuit normally operates close to ambient temperature due to its very low power consumption, thermal effects caused by large output current transients must be considered in certain applications.

SOIC-14 PACKAGE DRAWING

14 Pin Plastic SOIC Package

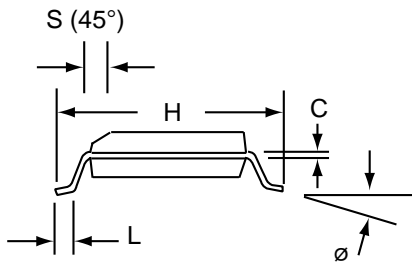
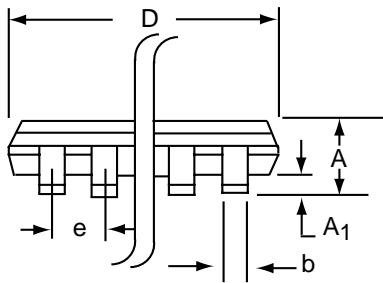
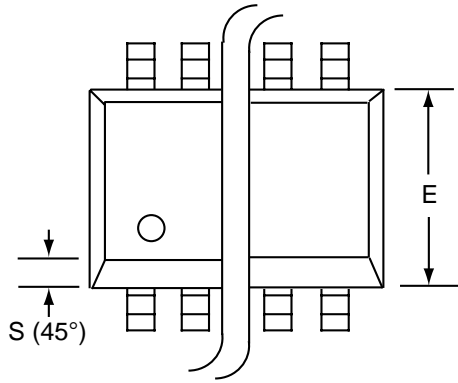

Dim	Millimeters		Inches	
	Min	Max	Min	Max
A	1.35	1.75	0.053	0.069
A ₁	0.10	0.25	0.004	0.010
b	0.35	0.45	0.014	0.018
C	0.18	0.25	0.007	0.010
D-14	8.55	8.75	0.336	0.345
E	3.50	4.05	0.140	0.160
e	1.27 BSC		0.050 BSC	
H	5.70	6.30	0.224	0.248
L	0.60	0.937	0.024	0.037
∅	0°	8°	0°	8°
S	0.25	0.50	0.010	0.020

PDIP-14 PACKAGE DRAWING

14 Pin Plastic DIP Package

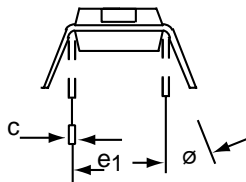
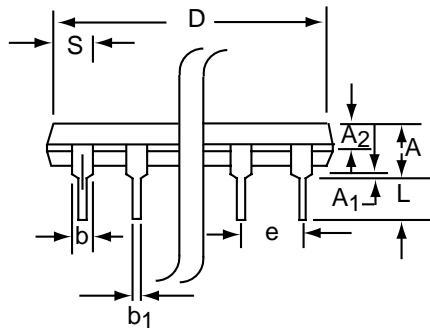
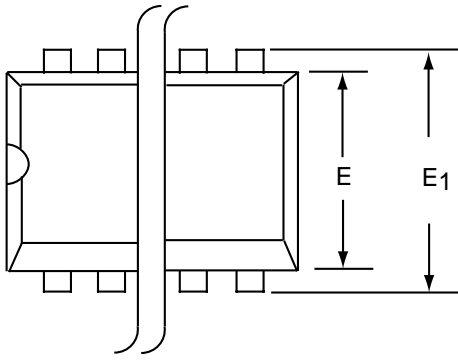

Dim	Millimeters		Inches	
	Min	Max	Min	Max
A	3.81	5.08	0.105	0.200
A ₁	0.38	1.27	0.015	0.050
A ₂	1.27	2.03	0.050	0.080
b	0.89	1.65	0.035	0.065
b ₁	0.38	0.51	0.015	0.020
c	0.20	0.30	0.008	0.012
D-14	17.27	19.30	0.680	0.760
E	5.59	7.11	0.220	0.280
E ₁	7.62	8.26	0.300	0.325
e	2.29	2.79	0.090	0.110
e ₁	7.37	7.87	0.290	0.310
L	2.79	3.81	0.110	0.150
S-14	1.02	2.03	0.040	0.080
θ	0°	15°	0°	15°

CERDIP-14 PACKAGE DRAWING

14 Pin CERDIP Package

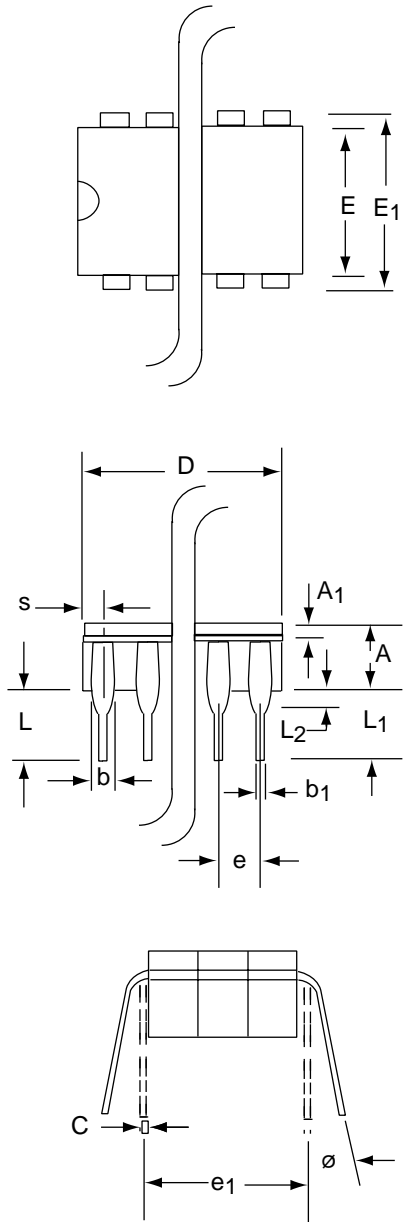

Dim	Millimeters		Inches	
	Min	Max	Min	Max
A	3.55	5.08	0.140	0.200
A₁	1.27	2.16	0.050	0.085
b	0.97	1.65	0.038	0.065
b₁	0.36	0.58	0.014	0.023
C	0.20	0.38	0.008	0.015
D-14	--	19.94	--	0.785
E	5.59	7.87	0.220	0.310
E₁	7.73	8.26	0.290	0.325
e	2.54 BSC		0.100 BSC	
e₁	7.62 BSC		0.300 BSC	
L	3.81	5.08	0.150	0.200
L₁	3.18	--	0.125	--
L₂	0.38	1.78	0.015	0.070
S	--	2.49	--	0.098
∅	0°	15°	0°	15°