

MARKETING SALES DRAWING
DIMENSIONS IN INCHES - DO NOT SCALE THIS DRAWING
DIMENSIONS IN METRIC - []

Electrical Testing
per Tusonix standard
test plans and Mil-Std-202
Test Methods.

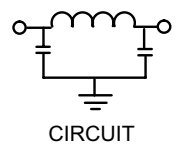
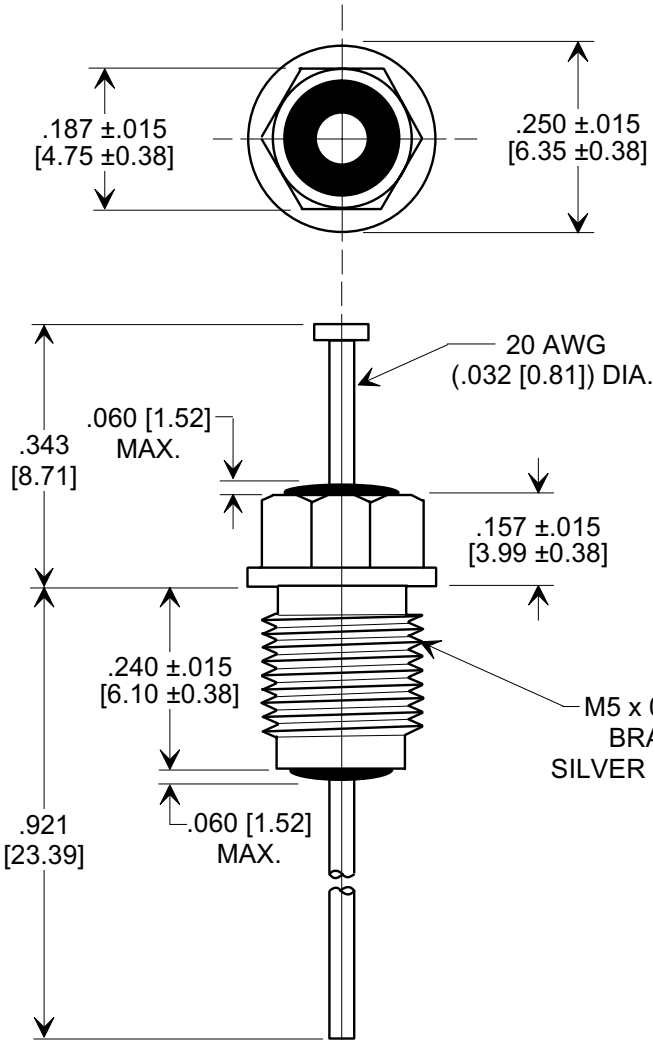
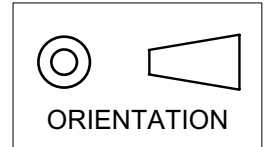

NOTES:

- TUSONIX STANDARD PART NUMBER: 4209-003.
TUSONIX RoHS COMPLIANT PART NUMBER: 4209-003 LF.
CUSTOMER MUST SPECIFY STANDARD OR RoHS PART NUMBER WHEN ORDERING.
- LEAD FINISH: STANDARD PART #: 60/40 SOLDER PLATED. RoHS PART #: SILVER PLATED.
- PART MARKING: TRADEMARK AND VARIATION NUMBER ON HEX FLATS.
STANDARD PART: BLACK INK. RoHS PART: GREEN INK.
- SUPPLIED WITH SILVER PLATED HEX NUT AND INTERNAL TOOTH LOCK WASHER.

MIN. CAP. (pF)	WORKING VOLTAGE (WVdc)		CURRENT IDC	MINIMUM NO LOAD INSERTION LOSS (dB) AT 25°C PER MIL-STD -220			
	85°C	125°C		10 MHz	100 MHz	1 GHz	10 GHz
1500	350	200	10 A	5	45	70	70

REVISION RECORD Original Release C.O. 4668 RDN TO COMP FMT. S.M. 05-09-00 2000508-3-01 ADDED NOTES. S.M. 05-29-05 20050727-2-02	0	 -- TOLERANCES -- Unless Otherwise Specified 2 Place Decimal 3 Place Decimal .031 Angles	Title BUSHING STYLE EMI FILTER	
			Drawn S.M. 05-09-00	
			Approved T.C. 05-09-00	
			A	4209-003

X-2015 Rev-0