

APPROVAL SHEET



WLSS124P Series
Shielded SMD Power Inductors

*Contents in this sheet are subject to change without prior notice.

Features

1. Shielded power inductor.
2. Wide inductance range.

Applications

1. Inductor in DC/DC converter.
2. Use in STB、PDA、Notebook.

Shape and Dimension

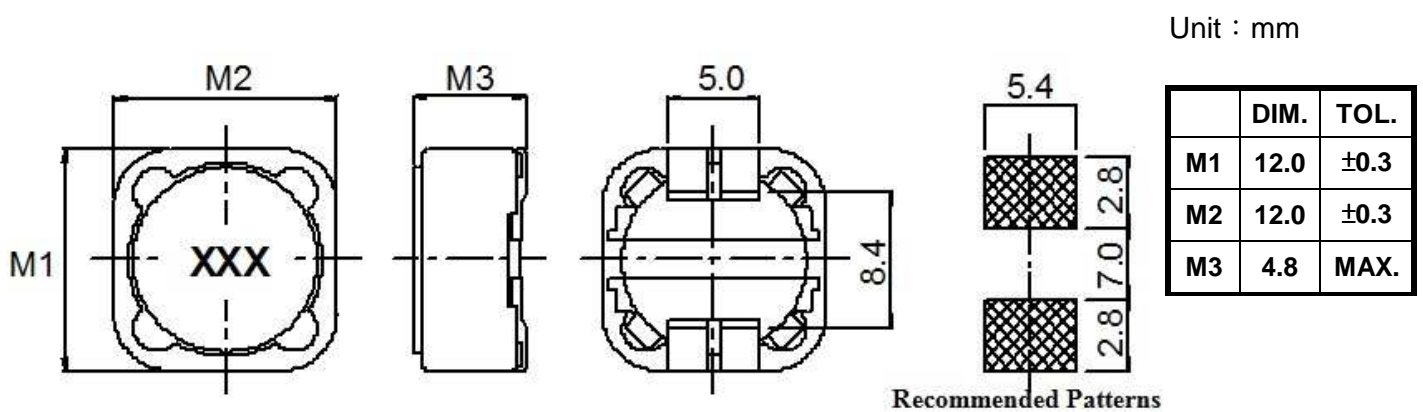

Ordering Information

WL	SS	124P	Z0	M	3R9	L	B
Product Code	Series	Dimensions	Series extension	Tolerance	Value	Packing Code	
WL: Inductor	Shielded SMD Power Inductors	12 * 12 mm	Z0:STD	M: ± 20%	3R9 = 3.9uH 100 = 10.0uH 101 =100uH	L=13" Reeled (Embossed tape)	B:STD

Electrical Characteristics

WLSS124P Series	Marking	L (uH)	Inductance Tolerance	Test Freq (KHz)	DCR (mΩ) MAX.	Rated Current (A)
WLSS124PZ0M3R9LB	3R9	3.9	±20%	100	15	6.50
WLSS124PZ0M4R7LB	4R7	4.7	±20%	100	18	5.70
WLSS124PZ0M6R8LB	6R8	6.8	±20%	100	23	4.90
WLSS124PZ0M8R2LB	8R2	8.2	±20%	100	26	4.60
WLSS124PZ0M100LB	100	10	±20%	100	28	4.50
WLSS124PZ0M120LB	120	12	±20%	100	38	4.00
WLSS124PZ0M150LB	150	15	±20%	100	50	3.20
WLSS124PZ0M180LB	180	18	±20%	100	57	3.10
WLSS124PZ0M220LB	220	22	±20%	100	66	2.90
WLSS124PZ0M270LB	270	27	±20%	100	80	2.80
WLSS124PZ0M330LB	330	33	±20%	100	97	2.70
WLSS124PZ0M390LB	390	39	±20%	100	132	2.10
WLSS124PZ0M470LB	470	47	±20%	100	150	1.90
WLSS124PZ0M560LB	560	56	±20%	100	190	1.80
WLSS124PZ0M680LB	680	68	±20%	100	220	1.50
WLSS124PZ0M820LB	820	82	±20%	100	260	1.30
WLSS124PZ0M101LB	101	100	±20%	100	308	1.20
WLSS124PZ0M121LB	121	120	±20%	100	380	1.10
WLSS124PZ0M151LB	151	150	±20%	100	530	0.95
WLSS124PZ0M181LB	181	180	±20%	100	620	0.85
WLSS124PZ0M221LB	221	220	±20%	100	700	0.80
WLSS124PZ0M271LB	271	270	±20%	100	870	0.60
WLSS124PZ0M331LB	331	330	±20%	100	990	0.50

- a. Tolerance : M : ±20%
- b. Operating Temp : -25°C to +105°C.
- c. Inductance measured using the HP4284A LCR meter, CHROMA1320 & 3302 & 16502
- d. DCR measured using the 502BC milli-ohm meter.
- e. Inductance drops no more than 25% of initial value at rated current, temperature rises $\Delta t < 40^\circ\text{C}$.
- ※MSL : LEVEL 1

TYPICAL RoHS REFLOW PROFILE

Typical RoHS Reflow Profile

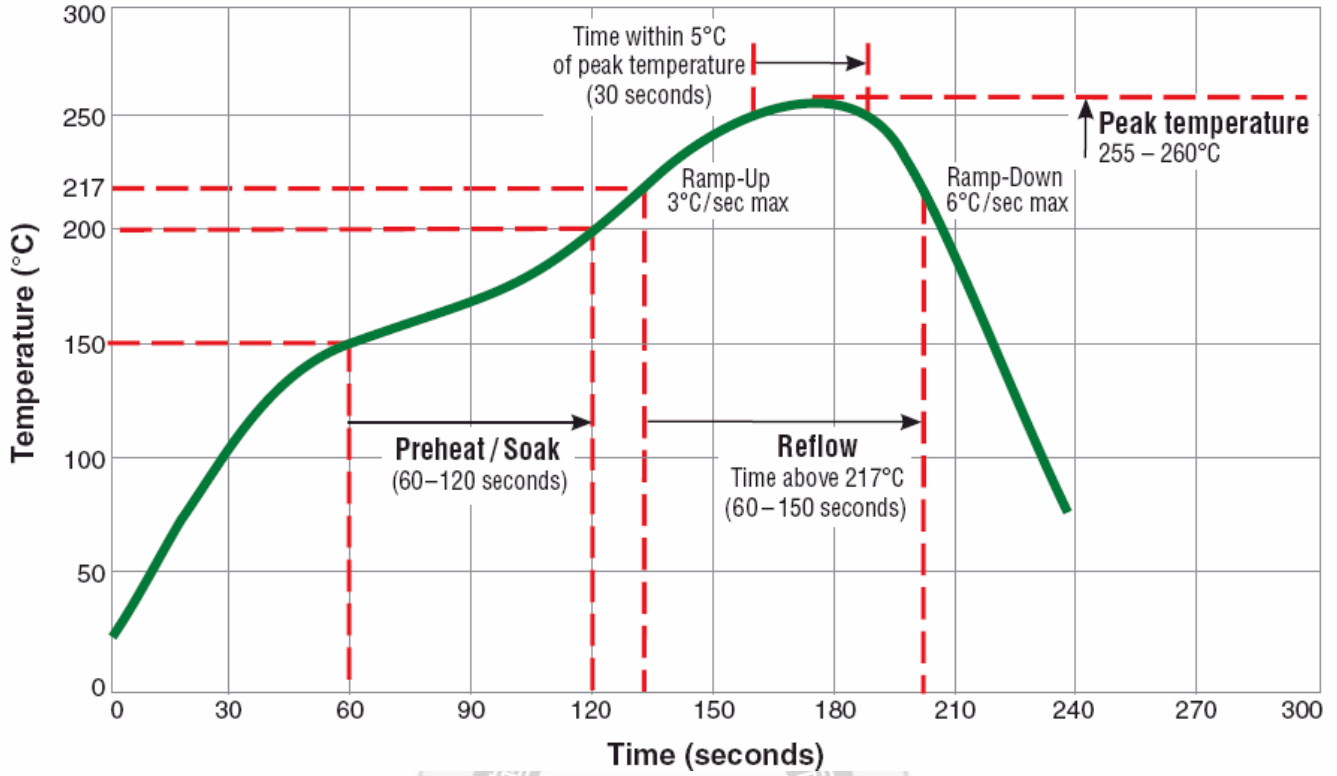

RELIABILITY PERFORMANCE

Reliability Experiment For Electrical

Test Item	Test Condition	Standard Source
Humidity Test	+40°C ± 2°C, humidity of 90% ± 5% (total 96 hours).	MIL-STD-202G Method 103B Test Condition B
High Temperature Test	1.Temperature: +125°C ± 2°C 2.Test time: 48 ± 2hrs	IEC 68-2 Test Condition B
Low Temperature Test	1.Temperature: -40°C ± 2°C 2.Test time: 48 ± 2hrs	IEC 68-2 Test Condition A
Thermal Shock	+125°C ± 5°C (30 minutes) ~ -40 ± 5°C (30 minutes), temperature switch time: 5 minutes (total 50 cycles).	MIL-STD-202G Method 107G Test Condition B-2
Life Test	+70°C ± 5°C (250Hours)	MIL-STD-202G Method 108A Test Condition B

Reliability Experiment For Physical

Test Item	Test Condition	Standard Source
Vibration Test	10-55-10HZ, amplitude: 1.5mm, direction: X, Y, Z axes, each axis 2 hours (total 6 hours).	MIL-STD-202G Method 201A
Solder Heat Resistance Test	IR/convection reflow: Peak Temp 250 ± 5°C for 5Sec in air, Through 2 Cycle. Temperature Ramp: +1 ~ 4°C/sec; Above 183°C, must keep 90 s - 120 s	MIL-STD-202G Method 210F Test Condition (Reflow)
Solder Ability Test	Soak in 245 °C solder pot of 3Sec, PAD must have 95% above coverage.	J-STD-003B

Tape & Reel Packaging Dimensions:

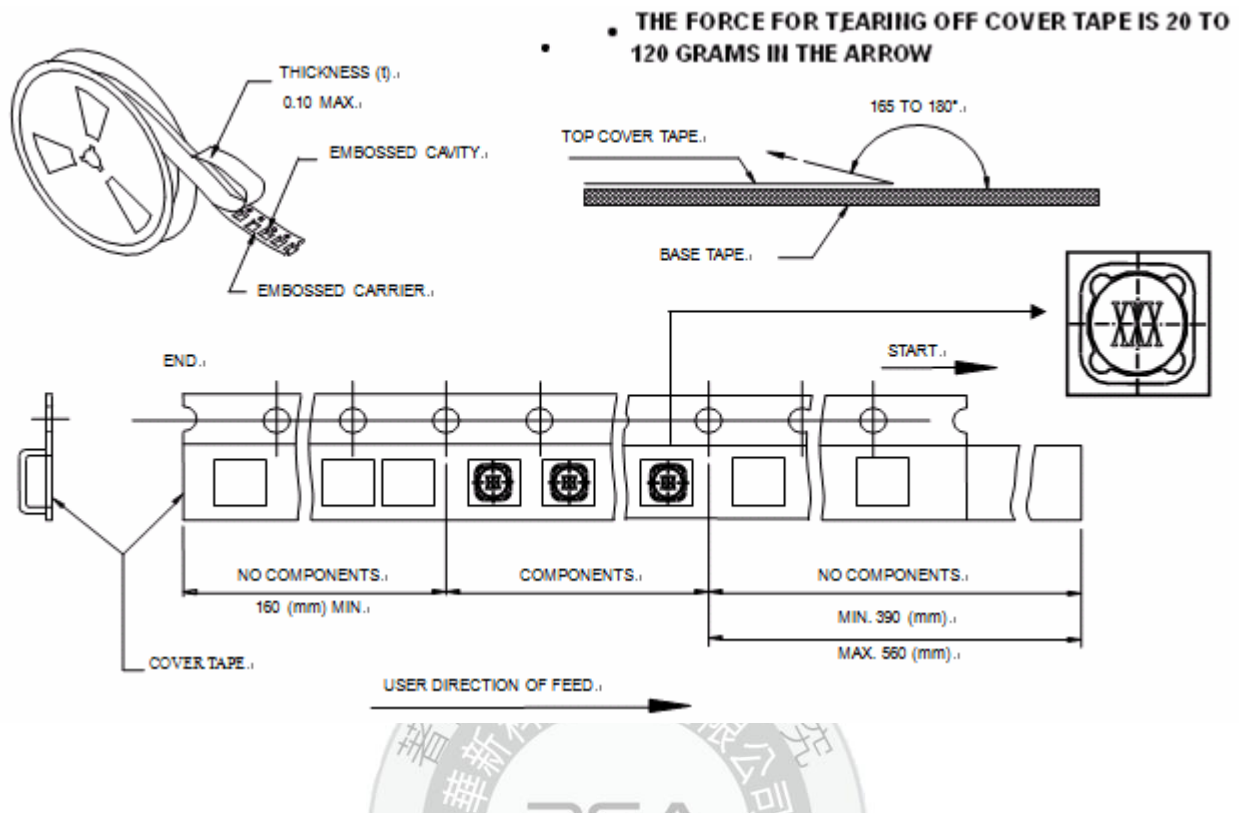

■ CARRIER TAPE REELS (mm)¹⁾

MATERIAL: PLASTIC

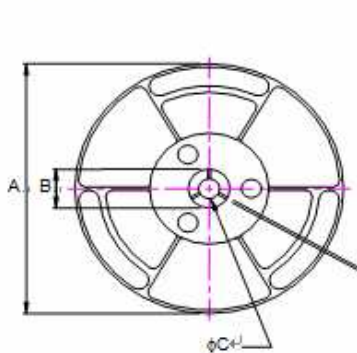

■ DIMENSIONS OF CARRIER TAPE (mm)¹⁾

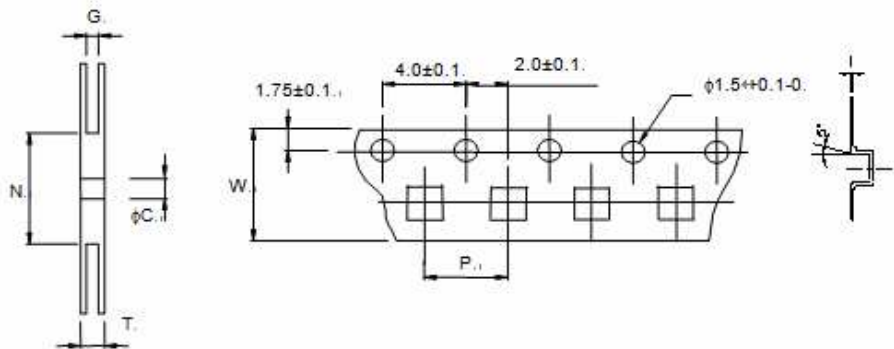

Unit : mm

	A	B	C	G	N	P	T	W	t
DIM.	340	20.2	13.0	25.0	100	16.0	30.5	24.0	0.35
TOL.	MAX	MIN	±0.5	+1.0-0.5	±0.3	±0.1	MAX	±0.3	±0.05

Quantity per reel : 750 pcs