

High Speed IGBT

IXSH 40N60B
IXST 40N60B

$V_{CES} = 600V$
 $I_{C25} = 75A$
 $V_{CE(sat)} = 2.2V$

$t_{fi\ typ} = 100\ ns$

Short Circuit SOA Capability

Preliminary data

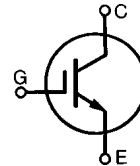

Symbol	Test Conditions	Maximum Ratings	
V_{CES}	$T_J = 25^\circ C$ to $150^\circ C$	600	V
V_{CGR}	$T_J = 25^\circ C$ to $150^\circ C$; $R_{GE} = 1\ M\Omega$	600	V
V_{GES}	Continuous	± 20	V
V_{GEM}	Transient	± 30	V
I_{C25}	$T_C = 25^\circ C$	75	A
I_{C90}	$T_C = 90^\circ C$	40	A
I_{CM}	$T_C = 25^\circ C$, 1 ms	150	A
SSOA (RBSOA)	$V_{GE} = 15\ V$, $T_J = 125^\circ C$, $R_G = 2.7\ \Omega$ Clamped inductive load, $V_{CC} = 0.8\ V_{CES}$	$I_{CM} = 80$ @ $0.8\ V_{CES}$	A
t_{SC} (SCSOA)	$V_{GE} = 15\ V$, $V_{CE} = 360\ V$, $T_J = 125^\circ C$ $R_G = 22\ \Omega$, non repetitive	10	μs
P_c	$T_C = 25^\circ C$	280	W
T_J		-55 ... +150	$^\circ C$
T_{JM}		150	$^\circ C$
T_{stg}		-55 ... +150	$^\circ C$
M_d	Mounting torque	1.13/10 Nm/lb.in.	
Weight		6	g
Maximum lead temperature for soldering 1.6 mm (0.062 in.) from case for 10 s		300	$^\circ C$

TO-247 AD (IXSH)

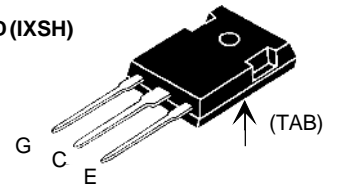

TO-268 (D3) (IXST)

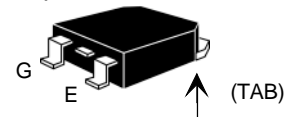

G = Gate
E = Emitter

TAB = Collector

Features

- International standard packages
- Guaranteed Short Circuit SOA capability
- Low $V_{CE(sat)}$
- for low on-state conduction losses
- High current handling capability
- MOS Gate turn-on
- drive simplicity
- Fast Fall Time for switching speeds up to 50 kHz

Applications

- AC and DC motor speed control
- Uninterruptible power supplies (UPS)
- Welding

Advantages

- Easy to mount with 1 screw (TO-247) (isolated mounting screw hole)
- High power density

Symbol	Test Conditions	Characteristic Values ($T_J = 25^\circ C$, unless otherwise specified)		
		min.	typ.	max.
BV_{CES}	$I_C = 250\ \mu A$, $V_{GE} = 0\ V$	600		V
$V_{GE(th)}$	$I_C = 4\ mA$, $V_{CE} = V_{GE}$	4		V
I_{CES}	$V_{CE} = 0.8 \cdot V_{CES}$ $V_{GE} = 0\ V$			$T_J = 25^\circ C$: 25 μA $T_J = 125^\circ C$: 1 mA
I_{GES}	$V_{CE} = 0\ V$, $V_{GE} = \pm 20\ V$			$\pm 100\ nA$
$V_{CE(sat)}$	$I_C = I_{C90}$, $V_{GE} = 15\ V$			2.2 V

Symbol	Test Conditions	Characteristic Values ($T_J = 25^\circ\text{C}$, unless otherwise specified)			
		min.	typ.	max.	
g_{fs}	$I_C = I_{C90}$; $V_{CE} = 10\text{ V}$, Pulse test, $t \leq 300\ \mu\text{s}$, duty cycle $\leq 2\%$	16	23	S	
C_{ies}	$V_{CE} = 25\text{ V}$, $V_{GE} = 0\text{ V}$, $f = 1\text{ MHz}$		3700	pF	
C_{oes}			280	pF	
C_{res}			80	pF	
Q_g	$I_C = I_{C90}$, $V_{GE} = 15\text{ V}$, $V_{CE} = 0.5 V_{CES}$		190	nC	
Q_{ge}			45	nC	
Q_{gc}			90	nC	
$t_{d(on)}$	Inductive load, $T_J = 25^\circ\text{C}$ $I_C = I_{C90}$, $V_{GE} = 15\text{ V}$, $L = 100\ \mu\text{H}$ $V_{CE} = 0.8 V_{CES}$, $R_G = 2.7\ \Omega$		50	ns	
t_{ri}			50	ns	
$t_{d(off)}$			110	200	ns
t_{fi}			120	200	ns
E_{off}			1.8	2.6	mJ
$t_{d(on)}$	Inductive load, $T_J = 125^\circ\text{C}$ $I_C = I_{C90}$, $V_{GE} = 15\text{ V}$, $V_{CE} = 0.8 V_{CES}$, $R_G = 2.7\ \Omega$		55	ns	
t_{ri}			170	ns	
E_{on}			1.7	mJ	
$t_{d(off)}$			190	ns	
t_{fi}			180	ns	
E_{off}		2.0	mJ		
R_{thJC}	(IXSH40N60B)			0.45 K/W	
R_{thCK}			0.25	K/W	

TO-247 AD (IXSH) Outline

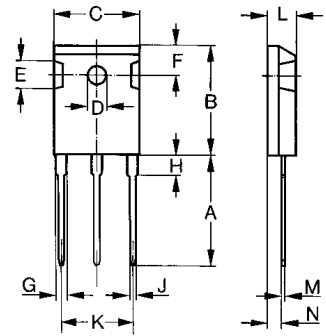

Dim.	Millimeter		Inches	
	Min.	Max.	Min.	Max.
A	19.81	20.32	0.780	0.800
B	20.80	21.46	0.819	0.845
C	15.75	16.26	0.610	0.640
D	3.55	3.65	0.140	0.144
E	4.32	5.49	0.170	0.216
F	5.4	6.2	0.212	0.244
G	1.65	2.13	0.065	0.084
H	-	4.5	-	0.177
J	1.0	1.4	0.040	0.055
K	10.8	11.0	0.426	0.433
L	4.7	5.3	0.185	0.209
M	0.4	0.8	0.016	0.031
N	1.5	2.49	0.087	0.102

TO-268AA (D³ PAK)

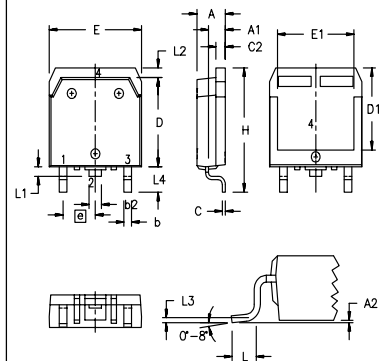

Dim.	Millimeter		Inches	
	Min.	Max.	Min.	Max.
A	4.9	5.1	.193	.201
A ₁	2.7	2.9	.106	.114
A ₂	.02	.25	.001	.010
b	1.15	1.45	.045	.057
b ₂	1.9	2.1	.75	.83
C	.4	.65	.016	.026
D	13.80	14.00	.543	.551
E	15.85	16.05	.624	.632
E ₁	13.3	13.6	.524	.535
e	5.45 BSC		.215 BSC	
H	18.70	19.10	.736	.752
L	2.40	2.70	.094	.106
L ₁	1.20	1.40	.047	.055
L ₂	1.00	1.15	.039	.045
L ₃	0.25 BSC		.010 BSC	
L ₄	3.80	4.10	.150	.161

Min. Recommended Footprint

