

DESIGNED & DIMENSIONED
IN INCHES[MILLIMETERS]

DO NOT
SCALE FROM
THIS PRINT

PRF92-P-C-EP-175-SS

SERIES
-92: 2.92mm

GENDER
-P: PLUG

TYPE
-C: CABLE

TERMINATION
-S: SOLDER CLAMP

ORIENTATION
-S: STRAIGHT

CABLE TYPE
-175: SEMFLEX LA180S

FINISH
-EP: 50µ" EXTRA HEAVY GOLD
CENTER CONTACT, PASSIVATED
OUTER CONTACT

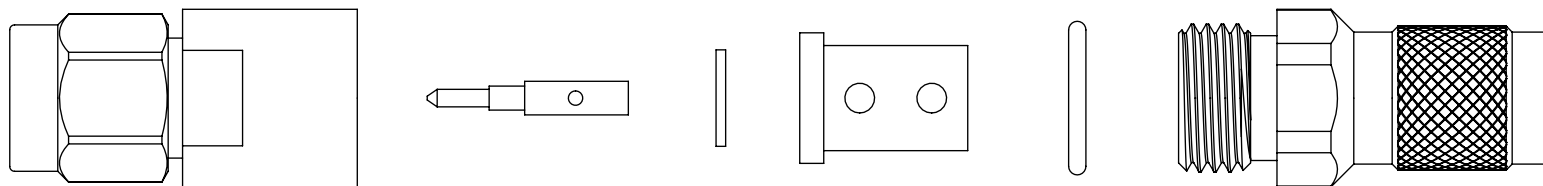
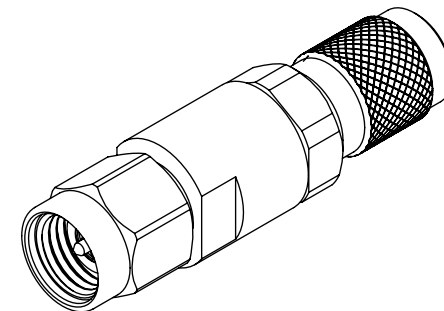
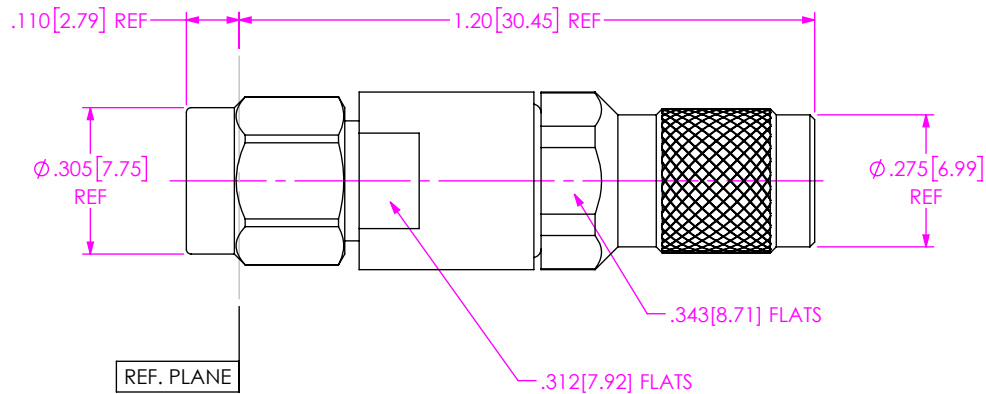

EXPLODED VIEW
NOT TO SCALE
(FOR CLARITY ONLY)

NOTES:

- MATERIAL:
BODY, COUPLING NUT & CLAMP NUT: STAINLESS STEEL.
PIN & LOCK RING: BERYLLIUM COPPER.
SOLDER FERRULE: BRASS.
GASKET & O-RING: SILICONE RUBBER.
CABLE STOP: ULTEM 1000.
DIELECTRIC BEAD: NORYL.
- FINISH:
BODY, COUPLING NUT & CLAMP NUT: PASSIVATED.
PIN & SOLDER FERRULE: GOLD OVER NICKEL PLATE,
50 µIN MIN GOLD OVER 50 µIN MIN NICKEL.
- NOTE DELETED.

UNLESS OTHERWISE SPECIFIED,
DIMENSIONS ARE IN INCHES.
TOLERANCES ARE:
DECIMALS ANGLES
.XX: ±.01 [0.3]
.XXX: ±.005 [0.13]
.XXXX: ±.0005 [0.013]

PROPRIETARY NOTE
THIS DOCUMENT CONTAINS CONFIDENTIAL AND
PROPRIETARY INFORMATION AND ALL DESIGN,
MANUFACTURING, REPRODUCTION, USE, PATENT RIGHTS
AND SALES RIGHTS ARE EXPRESSLY RESERVED BY SAMTEC,
INC. THIS DOCUMENT SHALL NOT BE DISCLOSED, IN WHOLE
OR PART, TO ANY UNAUTHORIZED PERSON OR ENTITY NOR
REPRODUCED, TRANSFERRED OR INCORPORATED IN ANY
OTHER PROJECT IN ANY MANNER WITHOUT THE EXPRESS
WRITTEN CONSENT OF SAMTEC, INC.



520 PARK EAST BLVD, NEW ALBANY, IN 47150
PHONE: 812-944-6733 FAX: 812-948-5047
e-Mail info@SAMTEC.com code 55322

DO NOT SCALE DRAWING

SHEET SCALE: 2.5:1

DESCRIPTION: 2.92MM PLUG, SOLDER CLAMP FOR
SEMFLEX LA180S CABLE

DWG. NO. PRF92-P-C-EP-175-SS

BY: SAMUEL C 08/31/2020 SHEET 1 OF 2

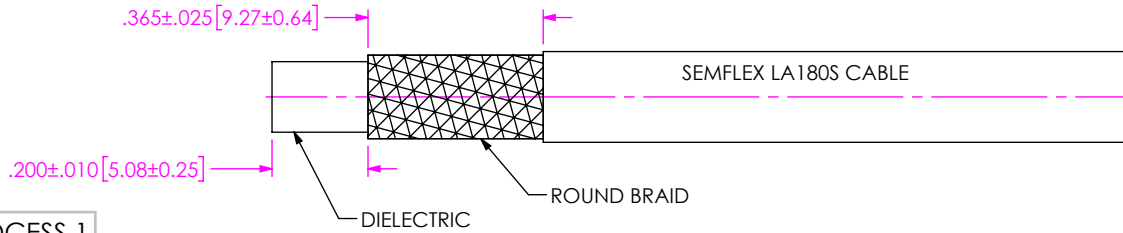

1. TRIM CABLE AS SHOWN.

IN-PROCESS 1

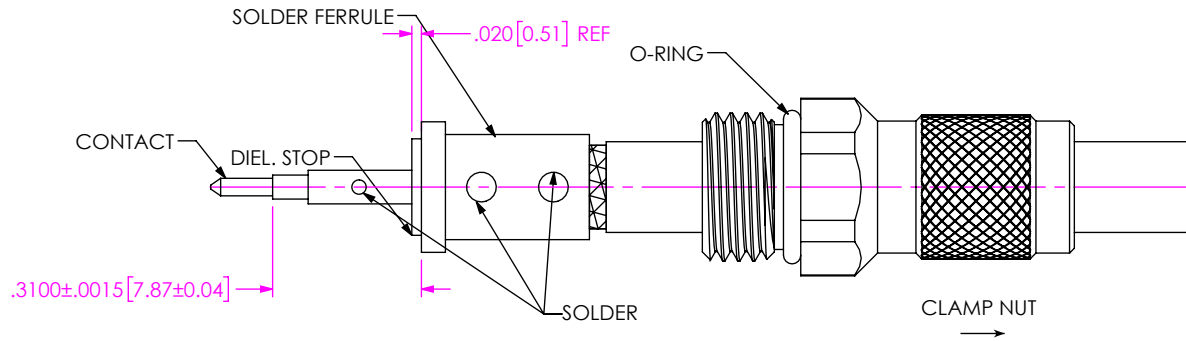

- 2A. SLIDE CLAMP NUT OVER CABLE IN ORIENTATION AS SHOWN.
- 2B. INSERT CABLE INTO SOLDER FERRULE UNTIL ROUND BRAID SEATS AND SOLDER TO BRAID WHERE SHOWN.
- 2C. TRIM CABLE DIELECTRIC FLUSH WITH FACE OF FERRULE.
- 2D. SLIDE DIELECTRIC STOP OVER CABLE CENTER CONDUCTOR AND SOLDER CONTACT FLUSH TO STOP TO DIMENSION SHOWN.

IN-PROCESS 2

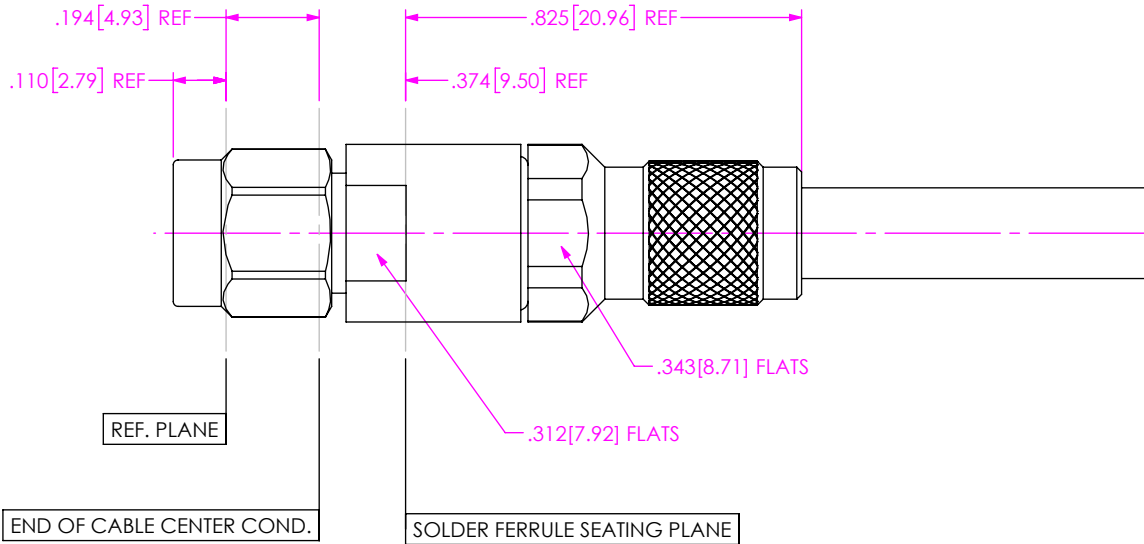

3. INSERT CABLE/CONTACT SUB-ASSEMBLY INTO CONNECTOR UNTIL SEATED AND TIGHTEN CLAMP NUT TO 25-35 IN.-LBS.

IN-PROCESS 3

<p>DO NOT SCALE DRAWING</p> <p>SHEET SCALE: 2.5:1</p>	<p>PROPRIETARY NOTE</p> <p>THIS DOCUMENT CONTAINS CONFIDENTIAL AND PROPRIETARY INFORMATION AND ALL DESIGN, MANUFACTURING, REPRODUCTION, USE, PATENT RIGHTS AND SALES RIGHTS ARE EXPRESSLY RESERVED BY SAMTEC, INC. THIS DOCUMENT SHALL NOT BE DISCLOSED, IN WHOLE OR PART, TO ANY UNAUTHORIZED PERSON OR ENTITY NOR REPRODUCED, TRANSFERRED OR INCORPORATED IN ANY OTHER PROJECT IN ANY MANNER WITHOUT THE EXPRESS WRITTEN CONSENT OF SAMTEC, INC.</p>	
	 <p>520 PARK EAST BLVD, NEW ALBANY, IN 47150 PHONE: 812-944-6733 FAX: 812-948-5047 e-Mail info@SAMTEC.com code 55322</p>	
	<p>DESCRIPTION: 2.92MM PLUG, SOLDER CLAMP FOR SEMFLEX LA180S CABLE</p>	<p>DWG. NO. PRF92-P-C-EP-175-SS</p>
<p>BY: SAMUEL C 08/31/2020 SHEET 2 OF 2</p>		