

REVISIONS			
ZONE/LTR	DESCRIPTION	DATE	APPROVAL
—	N/C	INITIAL RELEASE PER ECN # T-20420	8-29-95 HAGMANN

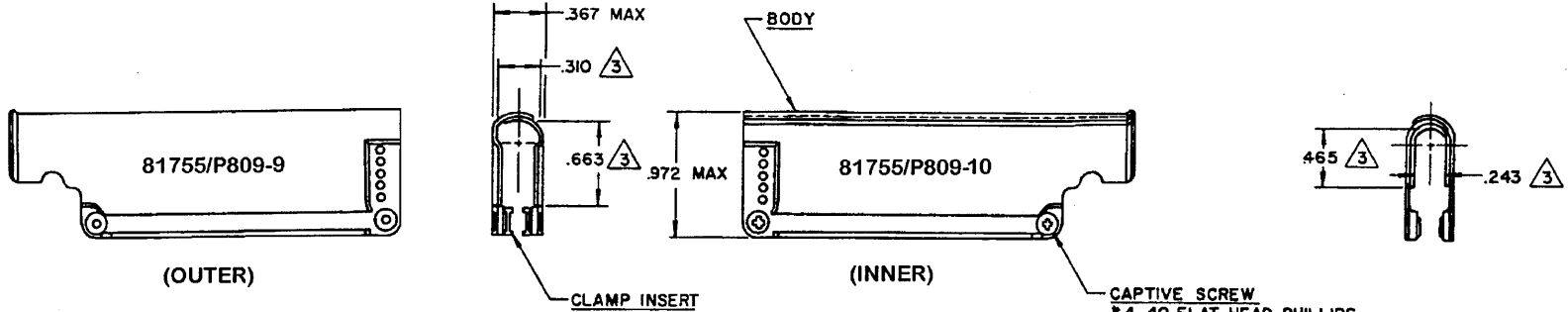

- NOTES:
- MATERIAL:
    - BODY; PHOSPHOR BRONZE PER ASTM B-139.
    - CAPTIVE SCREW; STAINLESS STEEL PER QQ-S-763, 300 SERIES.
    - CLAMP INSERT; FLUOROSILICONE ELASTOMER PER MIL-R-25988.
  - FINISH:
    - BODY; TIN PLATED PER MIL-T-10727 OVER NICKEL PER MIL-C-26074.
    - CAPTIVE SCREW; CADMIUM PLATED PER QQ-P-416
- ⚠ THESE DIMENSIONS ARE FOR MAXIMUM CABLE ACCOMMODATION.
- Raychem PART NUMBER IS MARKED ON BACKSHELL PACKAGE.
  - THIS BACKSHELL IS FOR USE WITH Raychem MTC SERIES CONNECTORS. 1" PLUG OR 1" RECEPTACLE AS SHOWN.

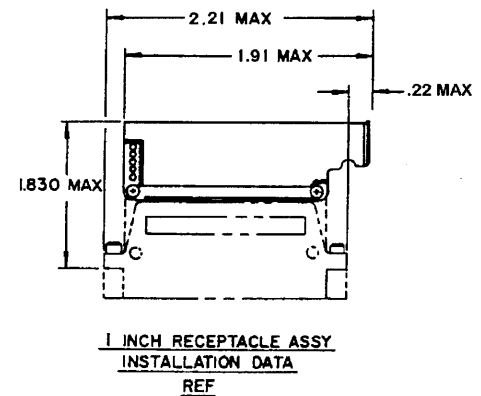
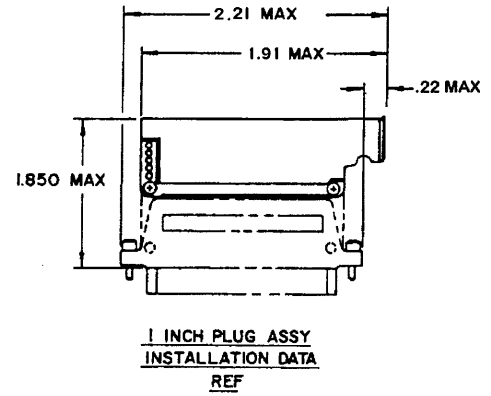

CUSTOMER P/N	RAYCHEM P/N	STYLE
81755/P809-9	CHA-0048-103	OUTER
81755/P809-10	CHA-0048-203	INNER

If this document is printed it becomes uncontrolled. Check for the latest revision

### SPECIFICATION CONTROL DRAWING

UNLESS OTHERWISE SPECIFIED DIMENSIONS ARE IN INCHES BRACKETED DIMENSIONS ( ) ARE METRIC AND TOLERANCES ARE:  .XXX: ± — ( — ) .XX: ± — ( — ) Δ: ± —	DRAWN	W.JACKSON	9-80	<b>Raychem</b> <small>RAYCHEM CORPORATION 303 CONSTITUTION DRIVE MENLO PARK, CALIFORNIA 94025</small>
	CHECKED	<i>B</i>		
	APPROVED	<i>Plain</i>	<i>7-20-80</i>	
	APPROVED			
				TITLE
				RIGHT ANGLE BREAKOUT BACKSHELL 1 INCH MTC
				SIZE
				A
				CODE IDENT
				NO. 08090
				DWG. NO.
				CHA-0048-X03
				WEIGHT
				SHEET 1 OF 1
				ORIGINAL DOCUMENT

DO NOT SCALE THIS DRAWING