

LOC		DIST		REVISIONS			
P	LTR	DESCRIPTION	DATE	DWN	APVD		
A		REV PER ECO 09-013463	6-19-09	CT	RL		

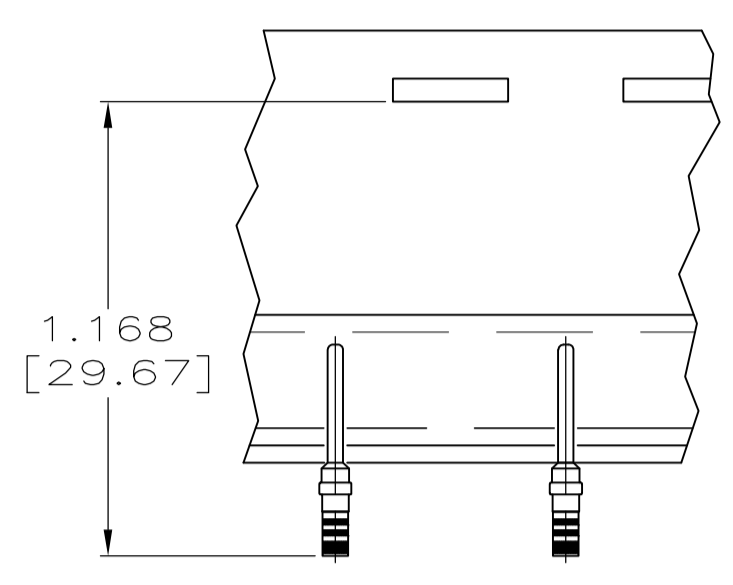

TAPE MOUNTED
 PART NO 1218371-2 ONLY
 SCALE 2:1

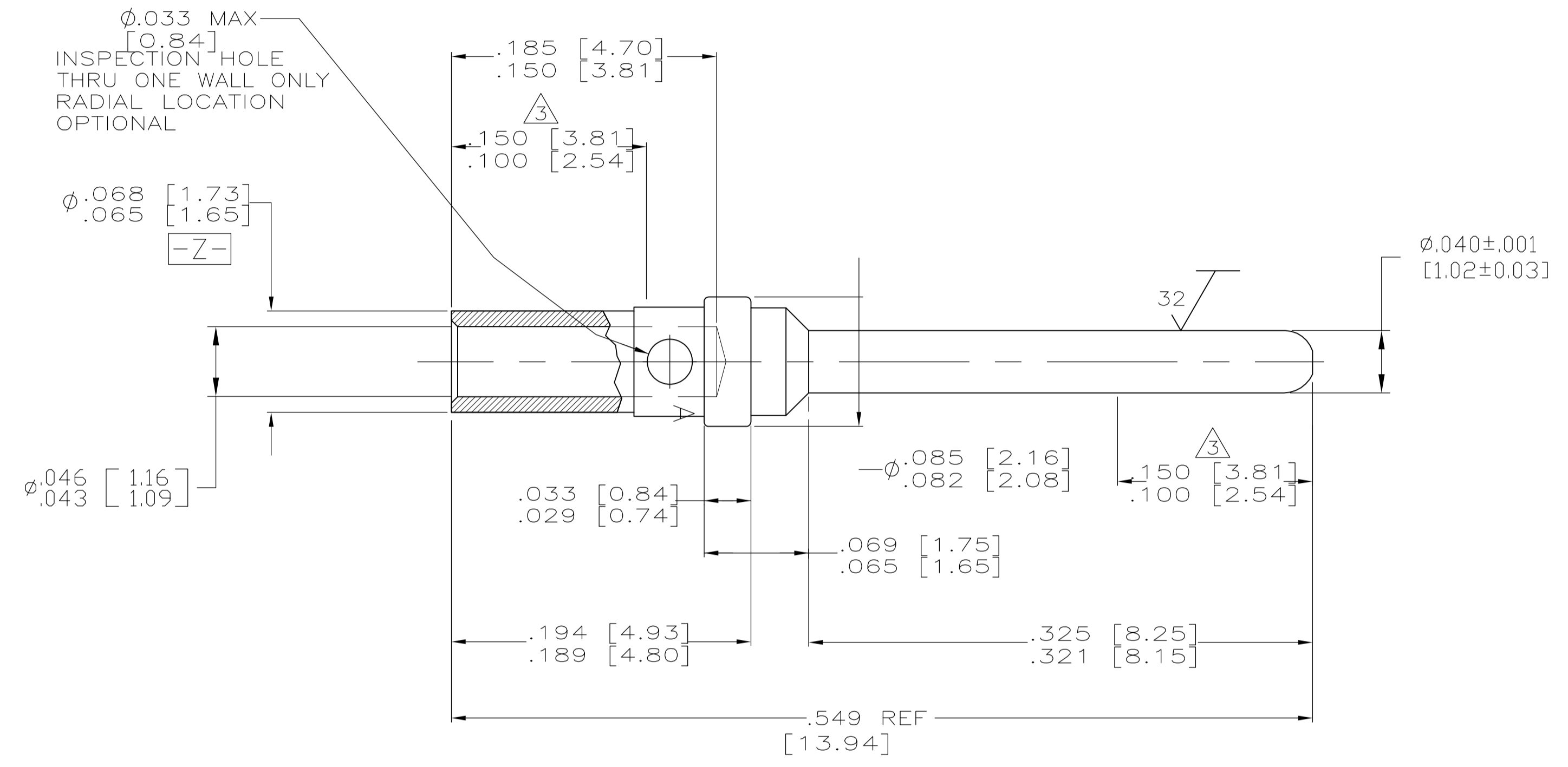
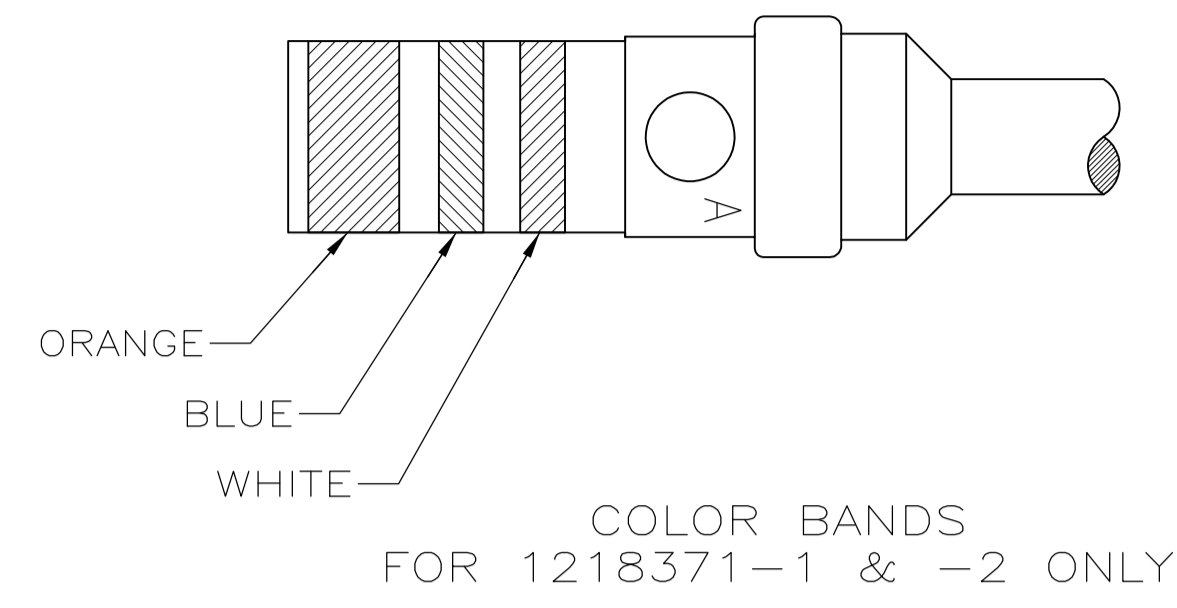

- △ FINISH: GOLD PLATED PER MIL-G-45204, TYPE II, OVER NICKEL PER QQ-N-290.
- △ FINISH: GOLD PLATED PER MIL-G-45204, TYPE II, OVER COPPER PER MIL-C-14550, CLASS 4.
- △ POINT OF PLATING THICKNESS MEASUREMENT. (2 PLC)
- 4. ALL DIAMETERS $\pm .004 Z$ UNLESS OTHERWISE SPECIFIED.
- 5. THIS PART COMPLIES WITH MIL-C-39029/64 AND M24308/11-1.
- 6. ALL SURFACES HAVE $A63\sqrt{}$ OR BETTER FINISH, UNLESS OTHERWISE SPECIFIED.

REMARKS	FINISH	PART NUMBER
SUPERSEDED BY 205089-2	WITHOUT COLOR CODE	1218371-3
SUPERSEDED BY 205089-1	CONTACTS ON TAPE	1218371-2
	AS SHOWN	1218371-1

THIS DRAWING IS A CONTROLLED DOCUMENT.

DIMENSIONS: INCHES	TOLERANCES UNLESS OTHERWISE SPECIFIED:	DIN C.C.THOMAS 1-25-99	1-25-99	Tyco Electronics Corporation Harrisburg, PA 17105-3608
		CHK R.GROSS	1-25-99	
		APVD R.GROSS	1-25-99	NAME #20 PIN, CRIMP, AMPLIMITE
		PRODUCT SPEC		
		APPLICATION SPEC		
MATERIAL	FINISH	WEIGHT	SIZE CAGE CODE DRAWING NO	RESTRICTED TO
			A1 00779 C=1218371	
CUSTOMER DRAWING		SCALE 15:1	SHEET 1 OF 1	REV A