

- *Designed for Front End GPS, Beidou, and Glonass Applications*
- *Steep Rejection*
- *2.0 x 1.6 x 1.0 mm Surface-Mount Case*
- *Complies with Directive 2002/95/EC (RoHS)*
- *Moisture Sensitivity Level: 1*
- *AEC-Q200 Qualified*

**SF2474H**

**1176 MHz  
SAW Filter**

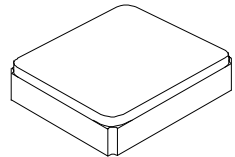

**SM2016-4**

**Absolute Maximum Ratings**

Rating	Value	Units
Input Power Level	+10	dBm
DC Voltage	3	VDC
Operable Temperature Range	-45 to +125	°C
Specification Temperature Range	-40 to +105	°C
Storage Temperature Range in Tape and Reel	-40 to +85	°C

**Electrical Characteristics**

Characteristic	Sym	NOTE	-40 to +105°C			UNITS
			MIN	TYPICAL	MAX	
Center Frequency	Fc			1176		MHz
Insertion Loss, 1156 to 1196 MHz	IL			3.2	3.3	dB
Group Delay Ripple, 1156 to 1196 MHz					5.0	ns
S11, 1156 to 1196 MHz			9.5	10		dB
Attenuation (reference level from 0 dB)						dB
DC to 920 MHz			25	27		
1350 to 1780 MHz			28	30		
1850 to 1910 MHz			30	32		
1920 to 1980 MHz			30	32		
2400 to 2500 MHz			35	38		
Temperature Coefficient of Frequency				-80		ppm/°C

Standard Reel Quantity	Reel Size: 7 inch	2000 Pieces/Reel
	Reel size: 13 inch	10,000 Pieces/Reel
Single-ended Input / Output Impedance Match		No matching network required for operation at 50 ohms
Package Size		SM2016-4
Lid Symbolization (Y=year, W=week)		C3, <u>YW</u>

**Electrical Connections**

Connection	Terminals
Input	1
Output	3
Ground	All others

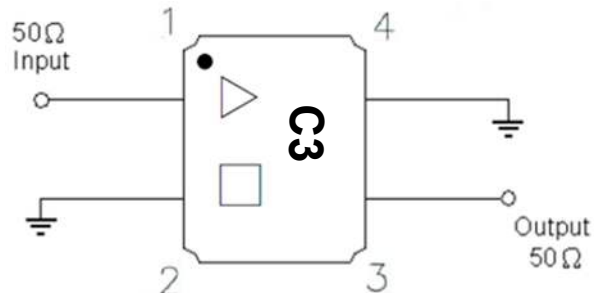

**CAUTION: Electrostatic Sensitive Device. Observe precautions for handling.**

**NOTES:**

1. The design, manufacturing process, and specifications of this device are subject to change.
2. US or International patents may apply.
3. RoHS compliant from the first date of manufacture.

# Frequency Characteristics

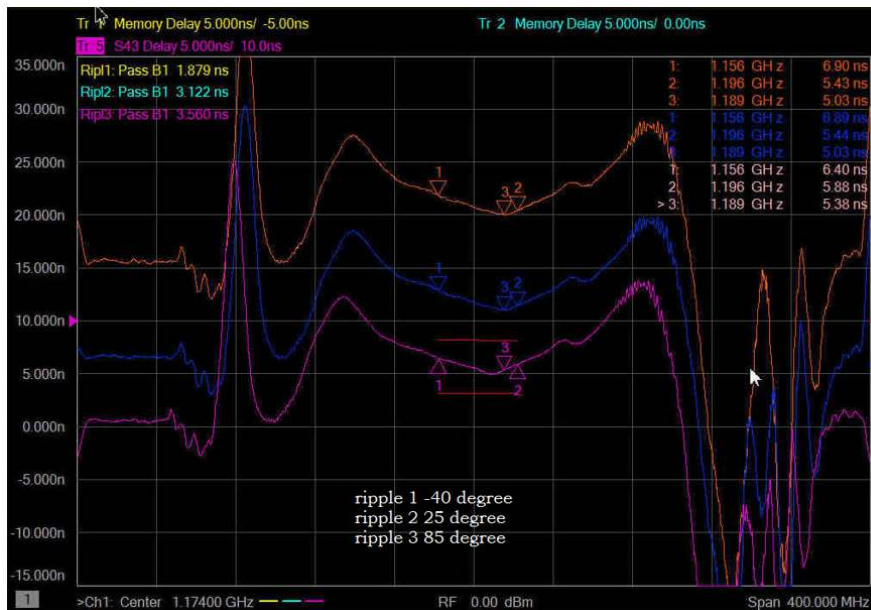
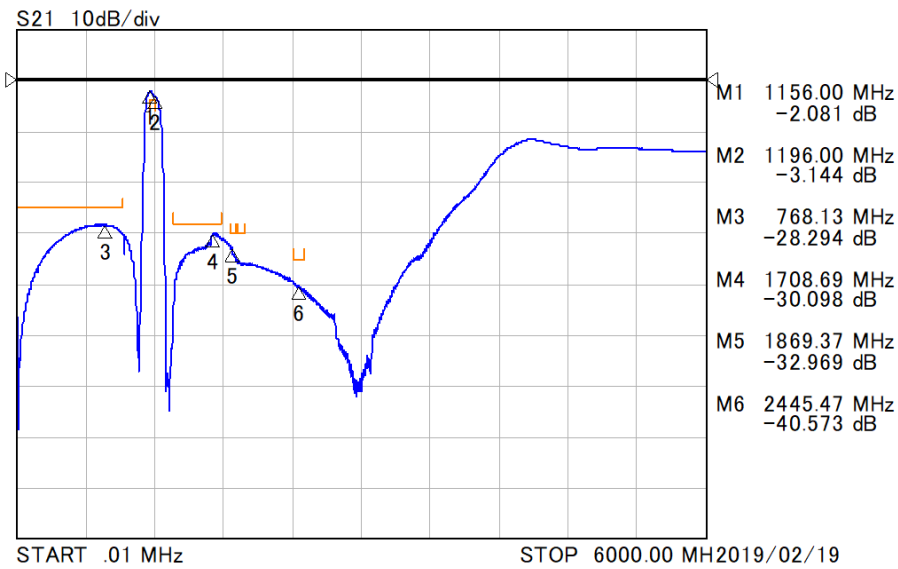
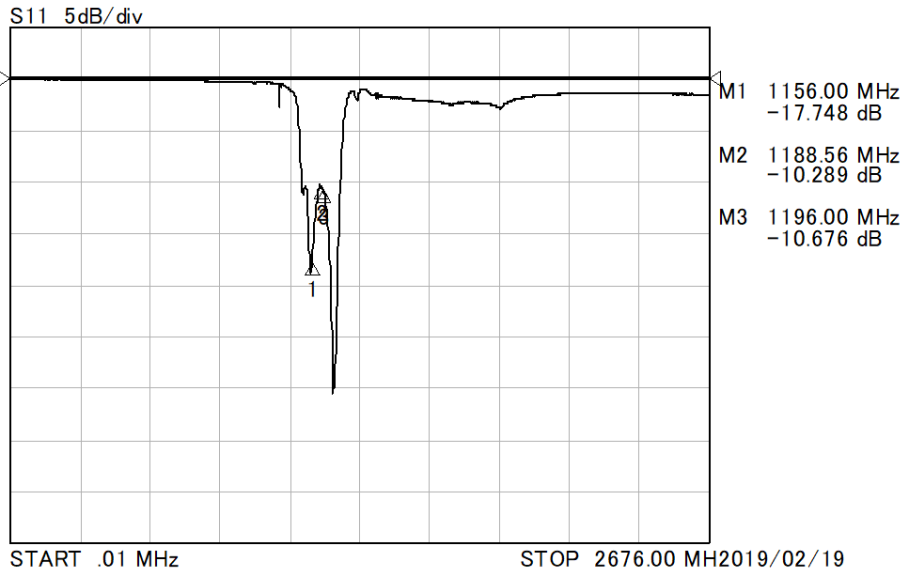

# SM2016-4 Case

## 4-Terminal Ceramic Surface-Mount Case

### 2.0 X 1.6 mm Nominal Footprint

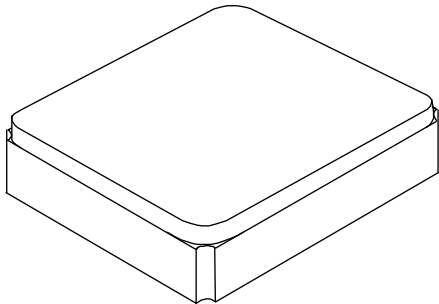

Case Dimensions

Dimension	mm		
	Min	Nom	Max
A	1.58	1.65	1.72
B	1.98	2.05	2.12
C	-	-	0.90
D	-	0.60	
E	-	0.425	
F	-	0.625	
G	-	0.10	

PCB Pad Layout

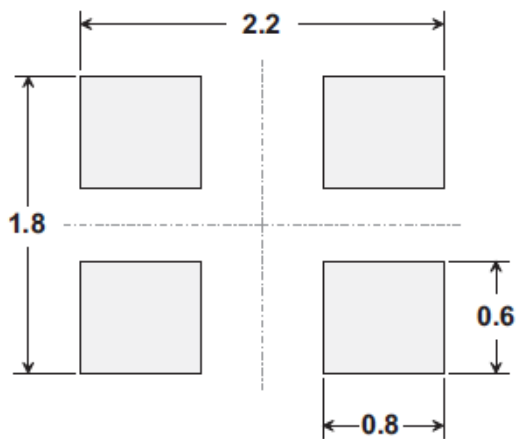

Materials	
Solder Pad Plating	0.3 to 1.0 $\mu\text{m}$ Gold over 1.27 to 8.89 $\mu\text{m}$ Nickel
Lid Plating	2.0 to 3.0 $\mu\text{m}$ Nickel
Body	$\text{Al}_2\text{O}_3$ Ceramic

Dimensions are in mm  
All pads have the same dimension

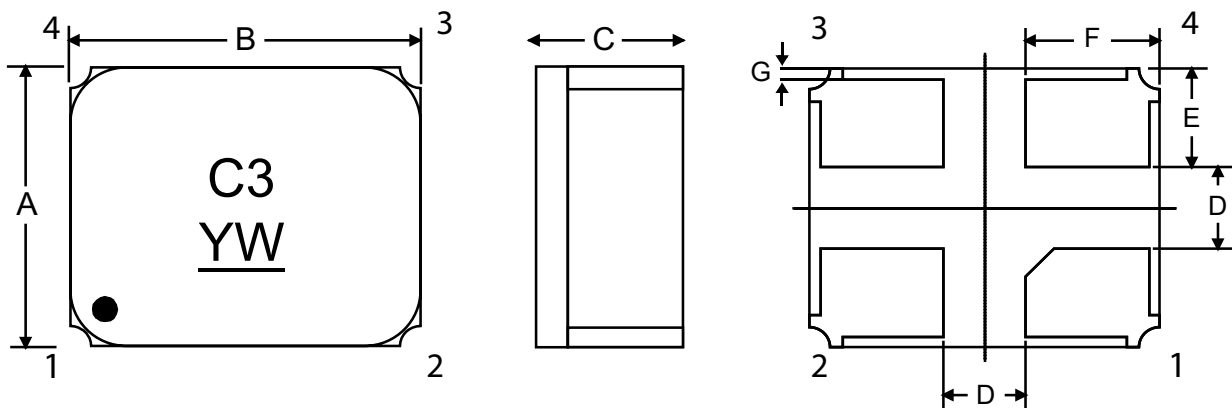

# Tape and Reel Specifications

Reel Count:  
 7" = 2000  
 13" = 10,000

Tape and Reel Standard per ANSI/EIA481

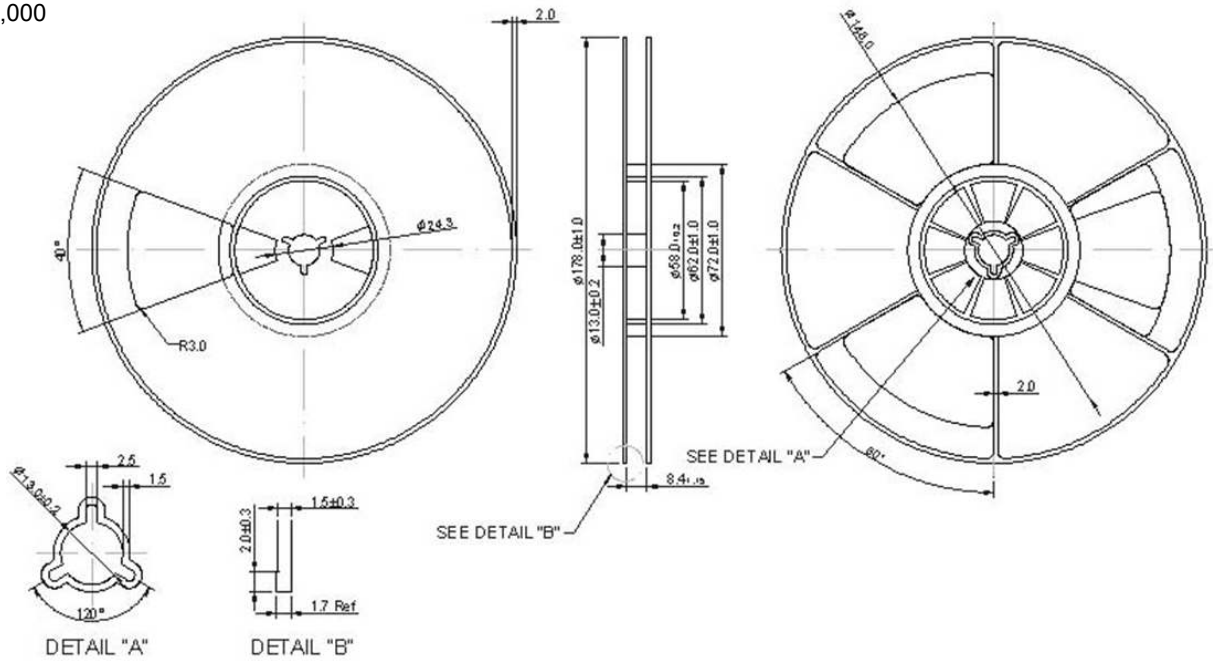

## Tape Dimensions

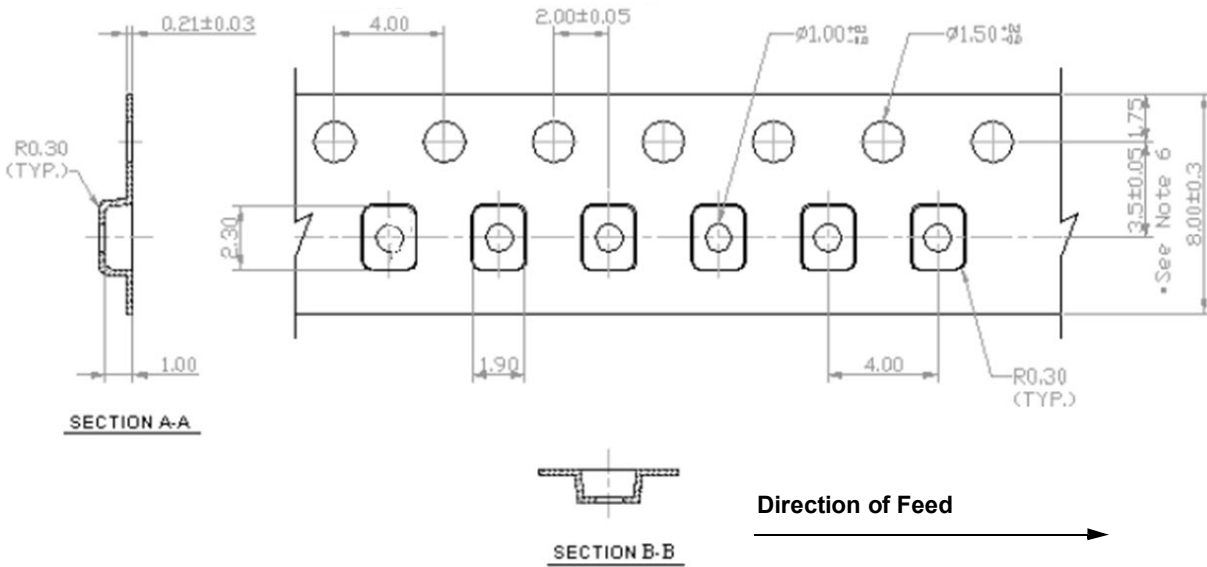

## Recommended Reflow Profile

1. Preheating shall be fixed at 150~180°C for 60~90 seconds.
2. Ascending time to preheating temperature 150°C shall be 30 seconds min.
3. Heating shall be fixed at 220°C for 50~80 seconds and at 260°C+0/-5°C peak (10 seconds).
4. Time: 5 times maximum.

