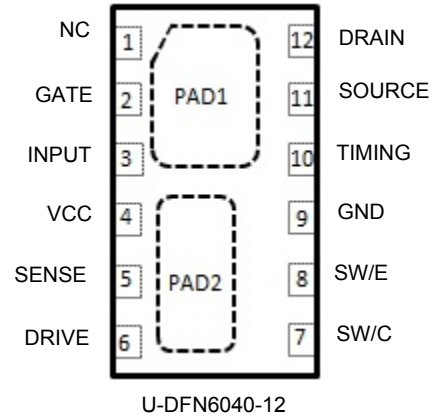


**BOOST/BUCK DC-DC CONVERTER FOR DIMMABLE MR16 LED LAMPS**

**Description**

The AL8812 is a monolithic control circuit containing the primary functions required for DC-to-DC converters with MOSFET in one package. These devices consist of an internal temperature compensated reference, comparator, controlled duty cycle oscillator with an active current limit circuit, driver and high current output switch. Additionally a 60V, 3.6A MOSFET is integrated for reduced BOM cost and size. This series is specifically designed for buck and boost applications with a minimum number of external components.

**Pin Assignments**



**Features**

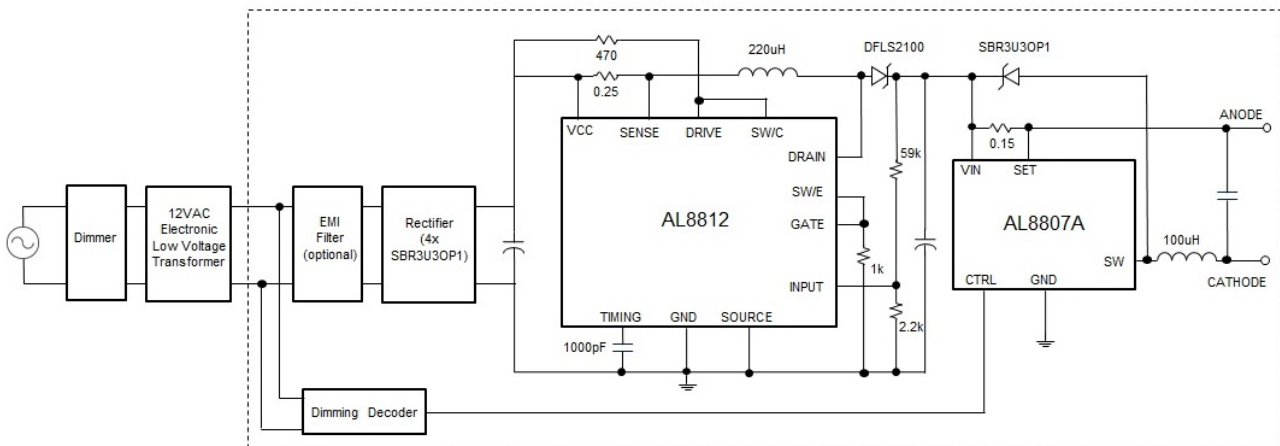
- Operation from 3.0V to 20V Input
- Integrated 60V, 3.6A MOSFET
- Low Standby Current
- Current Limiting
- Output Voltage Adjustable
- Frequency Operation to 100 kHz
- Precision 2% Reference
- **Totally Lead-Free & Fully RoHS Compliant (Notes 1 & 2)**
- **Halogen and Antimony Free. "Green" Device (Note 3)**

**Applications**

- Low Voltage LED Lighting such as MR-16
- General Purpose DC-DC Converter

Notes: 1. No purposely added lead. Fully EU Directive 2002/95/EC (RoHS) & 2011/65/EU (RoHS 2) compliant.  
 2. See [http://www.diodes.com/quality/lead\\_free.html](http://www.diodes.com/quality/lead_free.html) for more information about Diodes Incorporated's definitions of Halogen- and Antimony-free, "Green" and Lead-free.  
 3. Halogen- and Antimony-free "Green" products are defined as those which contain <900ppm bromine, <900ppm chlorine (<1500ppm total Br + Cl) and <1000ppm antimony compounds.

**Typical Applications Circuit**

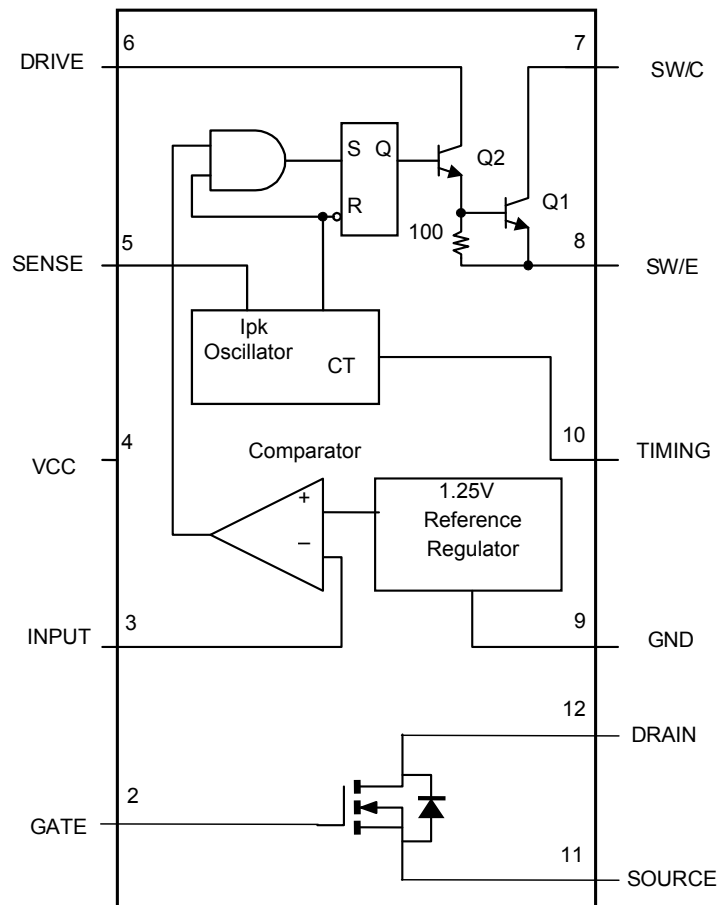


Dimmable MR-16 LED Driver System Diagram  
(For detailed schematic please contact your Diodes Sales Representative)

**Pin Descriptions**

Pin Name	Pin Number (U-DFN6040-12)	Function
NC	1	No Connection
GATE	2	Gate connection of internal MOSFET.
INPUT	3	Feedback pin for inverting input of internal comparator
VCC	4	Supply voltage pin
SENSE	5	No Connection.
DRIVE	6	Current drive collector: Normally connected to V <sub>CC</sub> directly or via a resistor.
SW/C	7	Internal switch transistor collector
SW/E	8	Internal switch transistor emitter
GND	9	Ground Connection
TIMING	10	Timing Capacitor to control the switching frequency.
SOURCE	11	Source connecton of internal MOSFET
DRAIN	12	Drain connection of internal MOSFET
Exposed PAD1		Exposed Pad of MOSFET Drain
Exposed PAD2		Exposed Pad of AL8812 and connect to PCB ground

**Functional Diagram**



**Absolute Maximum Ratings** (@T<sub>A</sub> = +25°C, unless otherwise specified.)

Symbol	Parameter	Value	Unit
V <sub>CC</sub>	Power Supply Voltage	20	V
V <sub>IR</sub>	Comparator Input Voltage Range	-0.3 to +36	V
SW/C	Switch Collector Voltage	36	V
SW/E	Switch Emitter Voltage (V <sub>Pin 1</sub> = 40V)	36	V
V <sub>CE (switch)</sub>	Switch Collector to Emitter Voltage	36	V
DRIVE	Driver Collector Voltage	36	V
I <sub>C (driver)</sub>	Driver Collector Current (Note 4)	100	mA
I <sub>SW</sub>	Switch Current	1.6	A
V <sub>DS</sub>	Maximum MOSFET Drain-Source voltage	60	V
V <sub>GS</sub>	Maximum MOSFET Gate-Source voltage	+/-20	V
I <sub>SOURCE</sub>	Maximum Continuous Source (Body Diode) Current	3.7	A
P <sub>D</sub>	Continuous Power Dissipation (T <sub>A</sub> = +25°C) (U-DFN6040-12 (derate 10mW/°C above +25°C))	1000	mW
θ <sub>JA</sub>	Junction-to-Ambient Thermal Resistance	47.31	°C/W
θ <sub>JC</sub>	Junction-to-Case Thermal Resistance	6.42	°C/W
T <sub>MJ</sub>	Maximum Junction Temperature	+150	°C
T <sub>OP</sub>	Operating Junction Temperature Range	0 to +105	°C
T <sub>stg</sub>	Storage Temperature Range	-65 to +150	°C
ESD HBM	Human Body Model ESD Protection	250	V
ESD MM	Machine Model ESD Protection	100	V

Note: 4. Maximum package power dissipation limits must be observed.

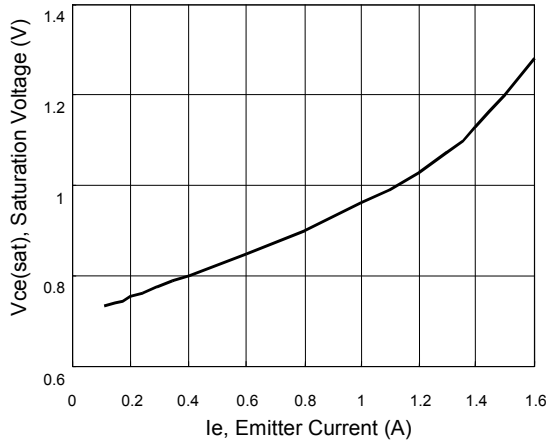
**Electrical Characteristics** (@T<sub>A</sub> = +25°C, unless otherwise specified.)

Symbol	Characteristics	Min	Typ	Max	Unit
<b>OSCILLATOR</b>					
f <sub>osc</sub>	Frequency (V <sub>PIN 5</sub> = 0V, C <sub>T</sub> = 1.0nF, T <sub>A</sub> = +25°C)	24	33	42	kHz
I <sub>chg</sub>	Charge Current (V <sub>CC</sub> = 5.0V to 40V, T <sub>A</sub> = +25°C)	24	30	42	μA
I <sub>dischg</sub>	Discharge Current (V <sub>CC</sub> = 5.0V to 40V, T <sub>A</sub> = +25°C)	140	200	260	μA
I <sub>dischg</sub> / I <sub>chg</sub>	Discharge to Charge Current Ratio (Pin 7 to V <sub>CC</sub> , T <sub>A</sub> = +25°C)	5.2	6.5	7.5	—
V <sub>ipk (sense)</sub>	Current Limit Sense Voltage (I <sub>chg</sub> = I <sub>dischg</sub> , T <sub>A</sub> = +25°C)	300	400	450	mV
<b>OUTPUT SWITCH (Note 5)</b>					
V <sub>CE (sat)</sub>	Saturation Voltage, Darlington Connection (I <sub>SW</sub> = 1.0A, Pins 1,8 connected)	—	1.0	1.3	V
V <sub>CE (sat)</sub>	Saturation Voltage, Darlington Connection (I <sub>SW</sub> = 1.0A, I <sub>D</sub> = 50mA, Forced β ≈ 20)	—	0.45	0.7	V
h <sub>FE</sub>	DC Current Gain (I <sub>SW</sub> = 1.0A, V <sub>CE</sub> = 5.0V, T <sub>A</sub> = +25°C)	50	75	—	—
I <sub>C (off)</sub>	Collector Off-State Current (V <sub>CE</sub> = 40V)	-	0.01	100	μA
<b>OUTPUT MOSFET</b>					
V <sub>GS(th)</sub>	MOSFET Gate Threshold voltage	1	—	2.2	V
V <sub>FD</sub>	MOSFET Diodes forward voltage	—	.85	.95	V
R <sub>DS(ON)</sub>	Drain-source on-resistance (V <sub>GS</sub> = 10V, I <sub>D</sub> = 2.5A) Drain-source on-resistance (V <sub>GS</sub> = 4.5V, I <sub>D</sub> = 2A)	—	—	120 180	mΩ
<b>COMPARATOR</b>					
V <sub>th</sub>	Threshold Voltage	—	—	—	V
—	T <sub>A</sub> = +25°C	1.225	1.25	1.275	—
—	T <sub>A</sub> = 0°C to +70°C	1.21	—	1.29	—
Reg <sub>line</sub>	Threshold Voltage Line Regulation (V <sub>CC</sub> = 3.0V to 40V)	—	1.4	6.0	mV
<b>TOTAL DEVICE</b>					
I <sub>CC</sub>	Supply Current (V <sub>CC</sub> = 5.0V to 40V, C <sub>T</sub> = 1.0nF, Pin 7 = V <sub>CC</sub> , V <sub>Pin 5</sub> > V <sub>th</sub> Pin 2 = Gnd, remaining pins open)	—	—	3.5	mA

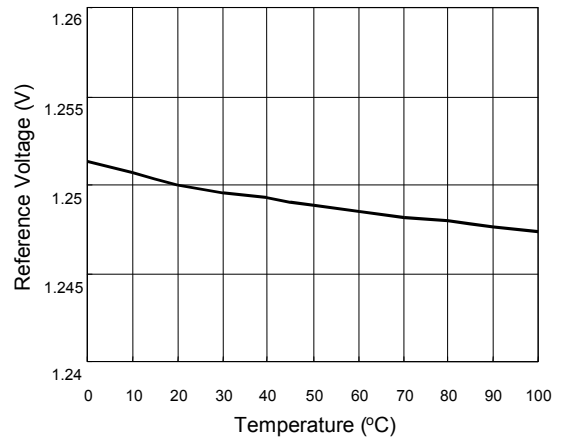
Note: 5. Low duty cycle pulse techniques are used during test to maintain junction temperature as close to ambient temperature as possible.

**Performance Characteristics**

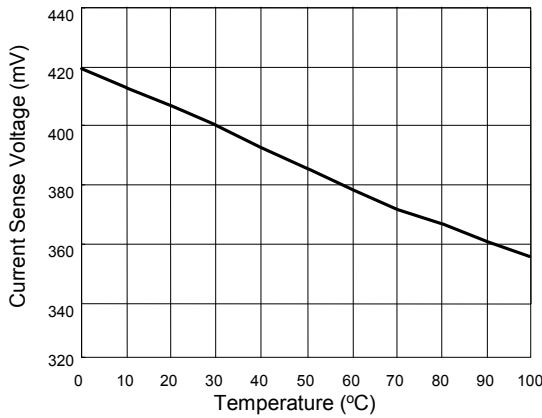
**Figure 1. Vce(sat) versus Ie**



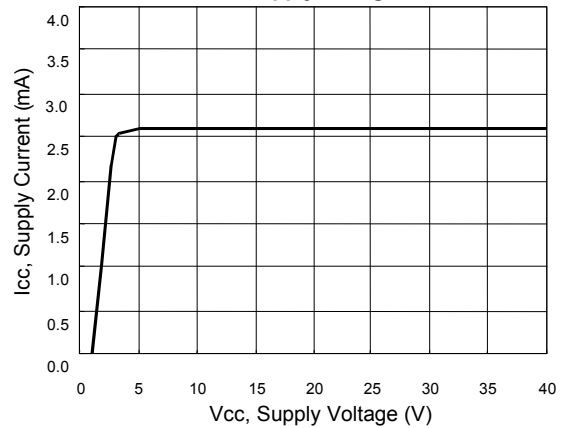
**Figure 2. Reference Voltage versus Temp.**



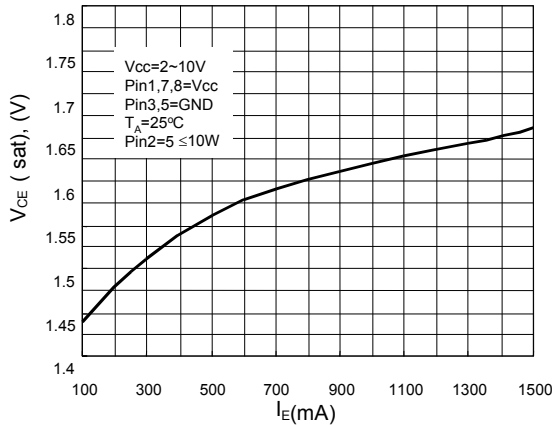
**Figure 3. Current Limit Sense Voltage versus Temperature**



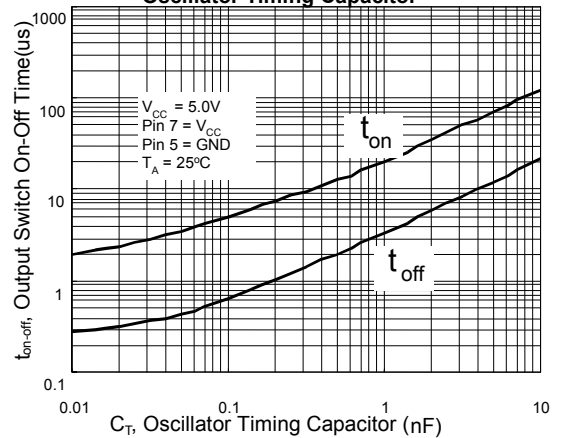
**Figure 4. Standby Supply Current versus Supply Voltage**

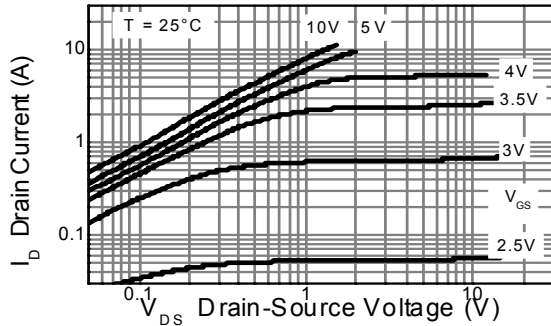


**Figure 5. Emitter Follower Configuration Output Saturation Voltage vs. Emitter Current**

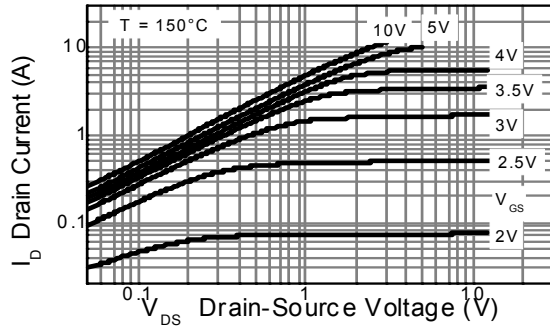


**Figure 6. Output Switch On-Off Time versus Oscillator Timing Capacitor**

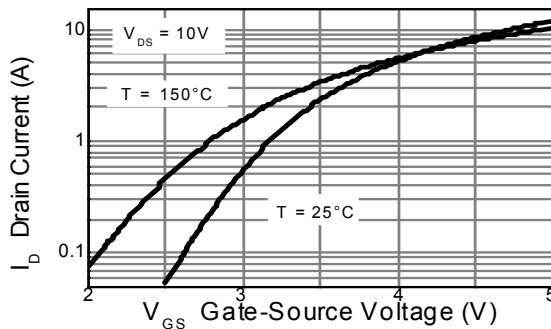




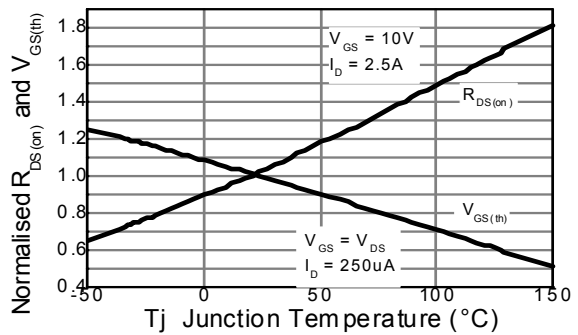
**Output Characteristics**



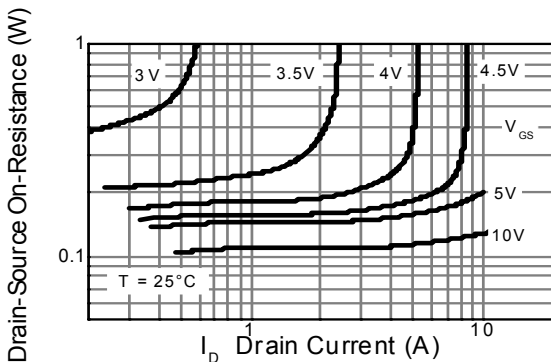
**Output Characteristics**



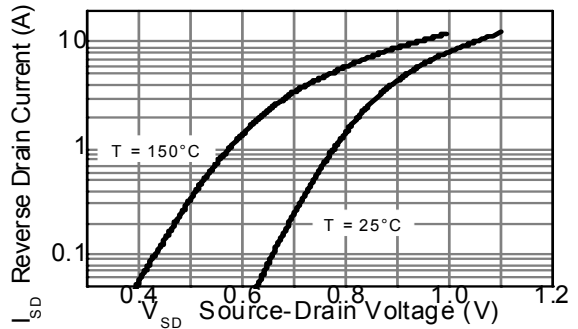
**Typical Transfer Characteristics**



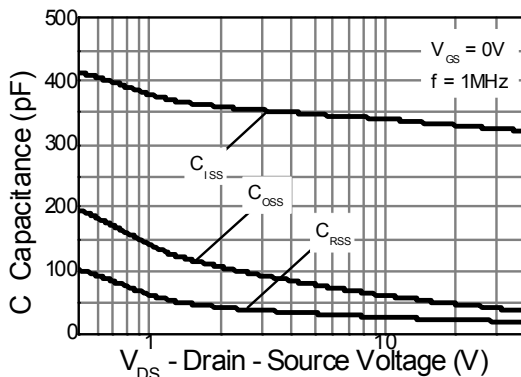
**Normalised Curves v Temperature**



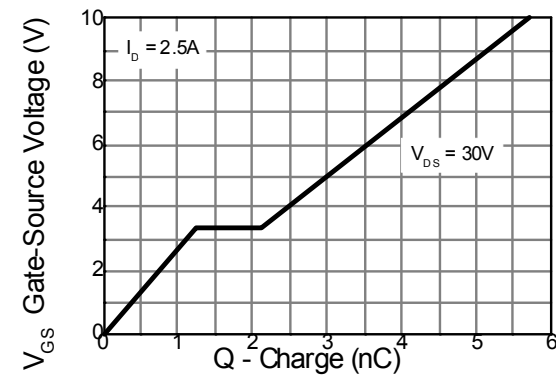
**On-Resistance v Drain Current**



**Source-Drain Diode Forward Voltage**



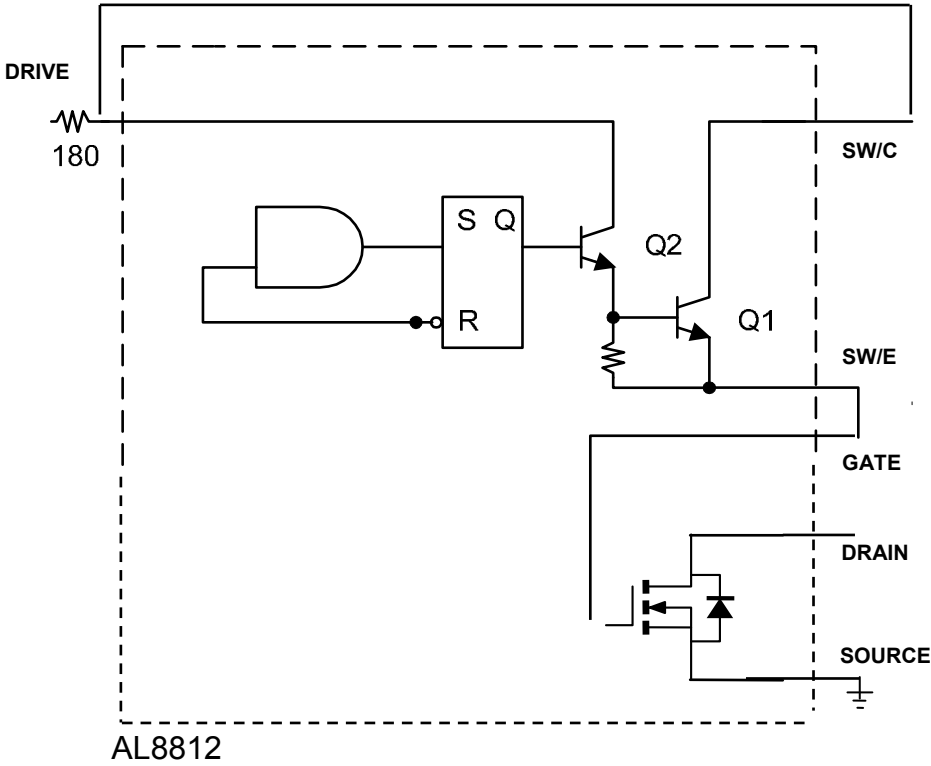
**Capacitance v Drain-Source Voltage**



**Gate-Source Voltage v Gate Charge**

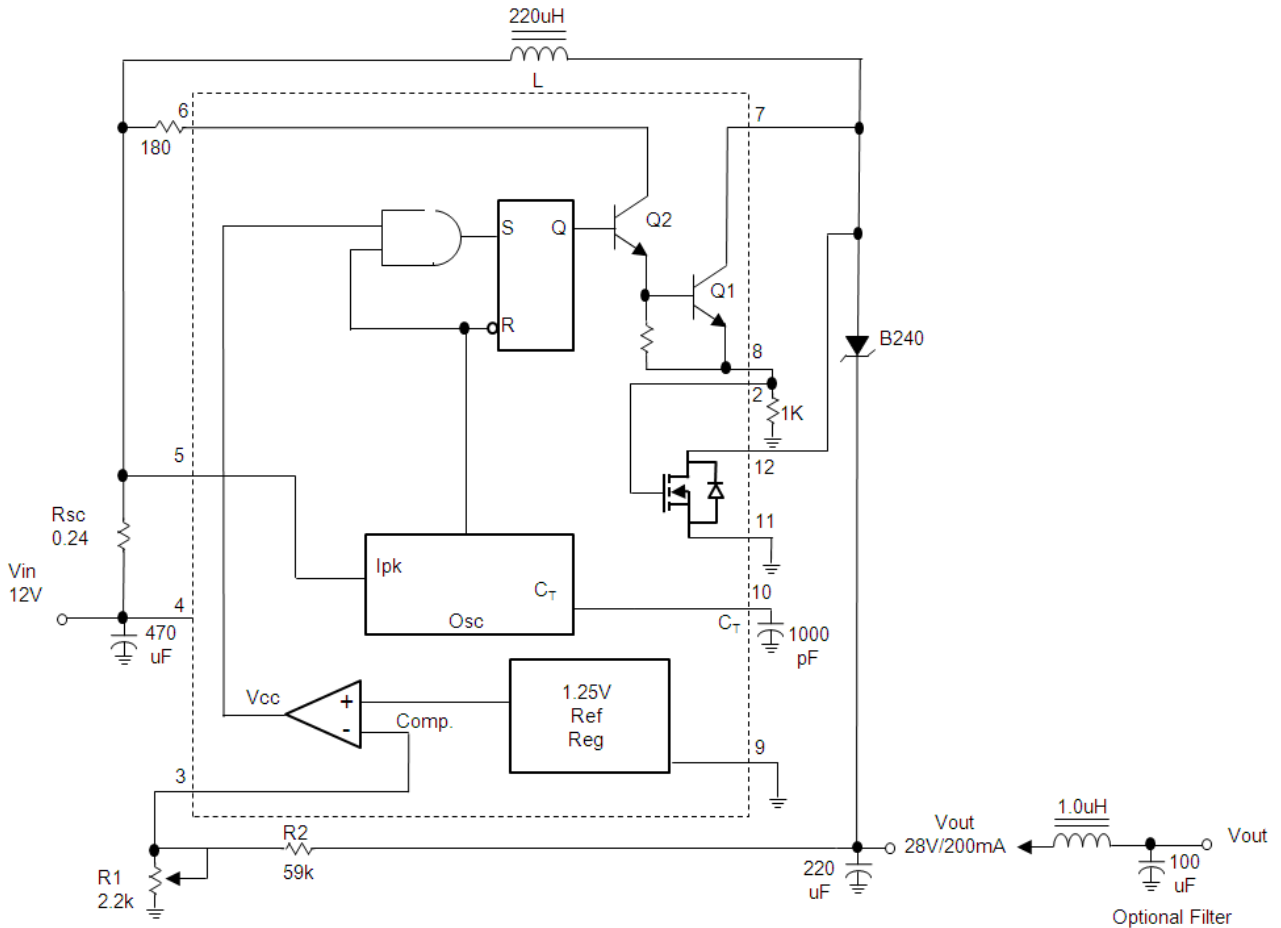
**Typical Application Circuits**

Circuits shown below represent connections employed for different topologies. To use the integrated MOSFET the typical configuration below can be used.



**Typical Application Circuits (cont.)**

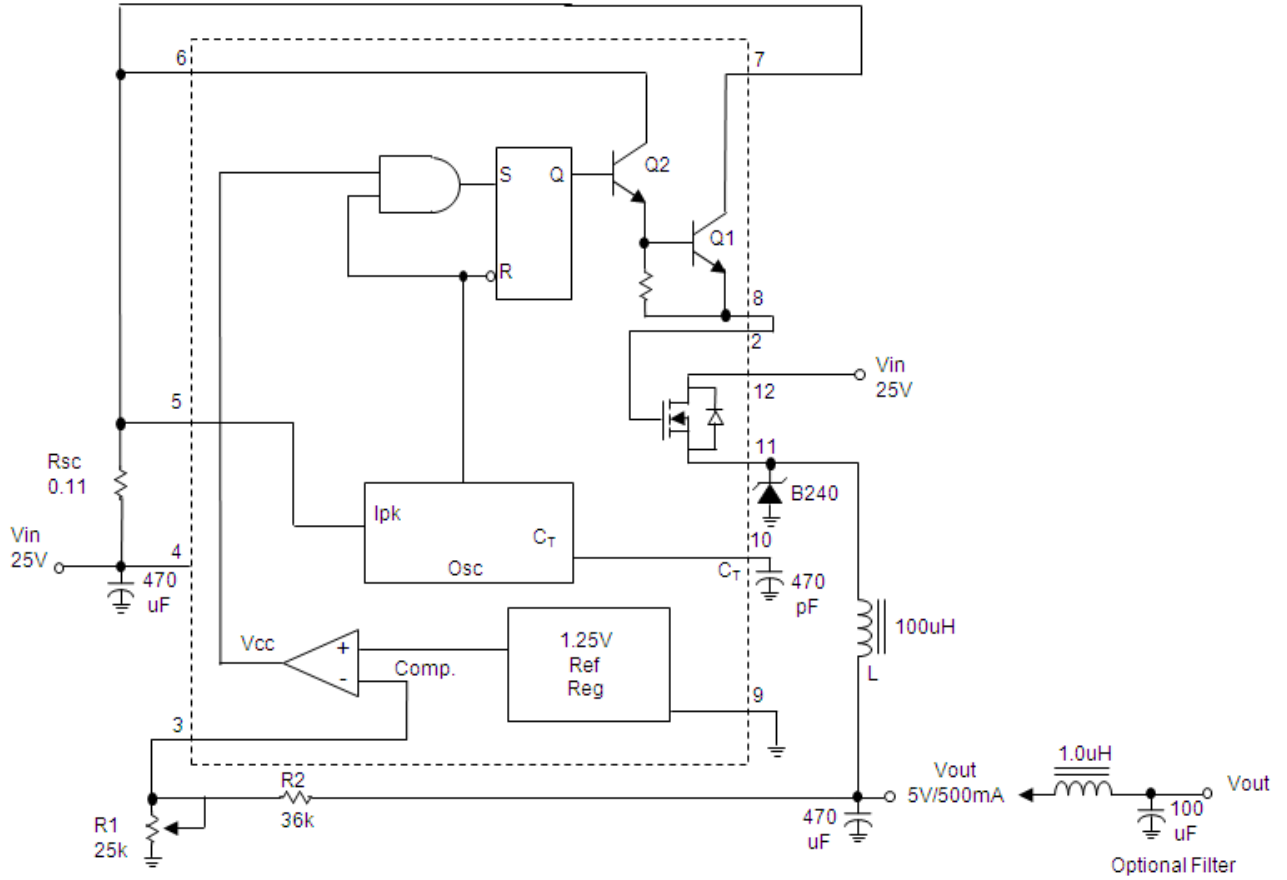
**Boost Converter**



Test	Conditions	Results
Line Regulation	$V_{in} = 9V \text{ to } 12V, I_O = 200mA$	$20mV = \pm 0.035\%$
Load Regulation	$V_{in} = 12V, I_O = 50mA \text{ to } 200mA$	$15mV = \pm 0.035\%$
Output Ripple	$V_{in} = 12V, I_O = 200mA$	$500mV_{PP}$
Efficiency	$V_{in} = 12V, I_O = 200mA$	80%

**Typical Application Circuits** (cont.)

**Buck Converter**



Test	Conditions	Results
Line Regulation	$V_{in} = 12V \text{ to } 24V, I_O = 500mA$	$20mV = \pm 0.2\%$
Load Regulation	$V_{in} = 24V, I_O = 50mA \text{ to } 500mA$	$5mV = \pm 0.05\%$
Output Ripple	$V_{in} = 24V, I_O = 500mA$	$160mV_{PP}$
Efficiency	$V_{in} = 24V, I_O = 500mA$	82%



## Design Formula Table

Calculation	Boost	Buck
$t_{ON} / t_{OFF}$	$V_{OUT} + V_F - V_{IN (min)}$	$V_{OUT} + V_F$
$(t_{ON} + t_{OFF})$	$V_{IN (min)} - V_{sat}$	$V_{IN (min)} - V_{SAT} - V_{OUT}$
$t_{OFF}$	$t_{ON} + t_{OFF}$	$t_{ON} + t_{OFF}$
	$t_{ON}$	$t_{ON}$
	$t_{OFF}$	$t_{OFF}$
	+1	+1
$t_{ON}$	$(t_{ON} + t_{OFF}) - t_{OFF}$	$(t_{ON} + t_{OFF}) - t_{OFF}$
$C_T$	$4.0 \times 10^{-5} t_{ON}$	$4.0 \times 10^{-5} t_{ON}$
$I_{pk (switch)}$	$2I_{OUT (max)} (t_{ON} / t_{OFF} + 1)$	$2I_{OUT (max)}$
$R_{sc}$	$0.3 / I_{pk (switch)}$	$0.3 / I_{pk (switch)}$
$L (min)$	$(V_{IN (min)} - V_{sat}) / I_{pk (switch)}$	$(V_{IN (min)} - V_{SAT} - V_{OUT}) / I_{pk (switch)}$
	$t_{on (max)}$	$ON (max)$
$C_O$	9	
	$I_{OUT} t_{ON}$	$I_{pk (switch)} (t_{OFF} + t_{ON})$
	$V_{ripple (pp)}$	$8V_{ripple (pp)}$

$V_{sat}$  = Saturation voltage of the output switch.

$V_F$  = Forward voltage drop of the output rectifier.

**The following power supply characteristics must be chosen:**

$V_{IN}$  - Nominal input voltage.

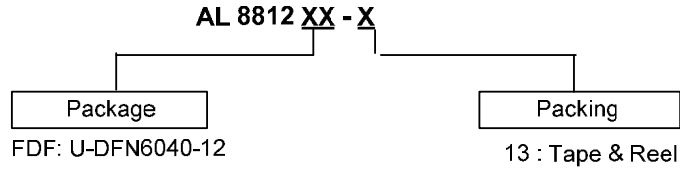
$V_{OUT}$  - Desired output voltage,  $|V_{OUT}| = 1.25 (1+R2/R1)$

$I_{OUT}$  - Desired output current.

$f_{min}$  - Minimum desired output switching frequency at the selected values of  $V_{in}$  and  $I_o$ .

$V_{ripple(pp)}$  - Desired peak-to-peak output ripple voltage. In practice, the calculated capacitor value will need to be increased due to its equivalent series resistance and board layout. The ripple voltage should be kept to a low value since it will directly affect the line and load regulation.

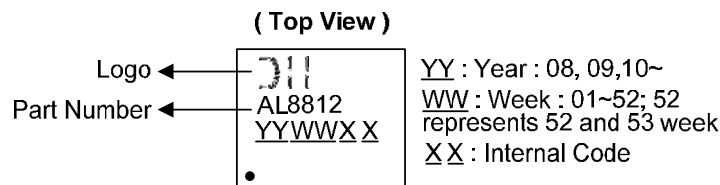
**Ordering Information**



Part Number	Package Code	Packaging	Tube		13" Tape and Reel	
			Quantity	Part Number Suffix	Quantity	Part Number Suffix
AL8812FDF-13	FDF	U-DFN6040-12	NA	NA	3000/Tape & Reel	-13

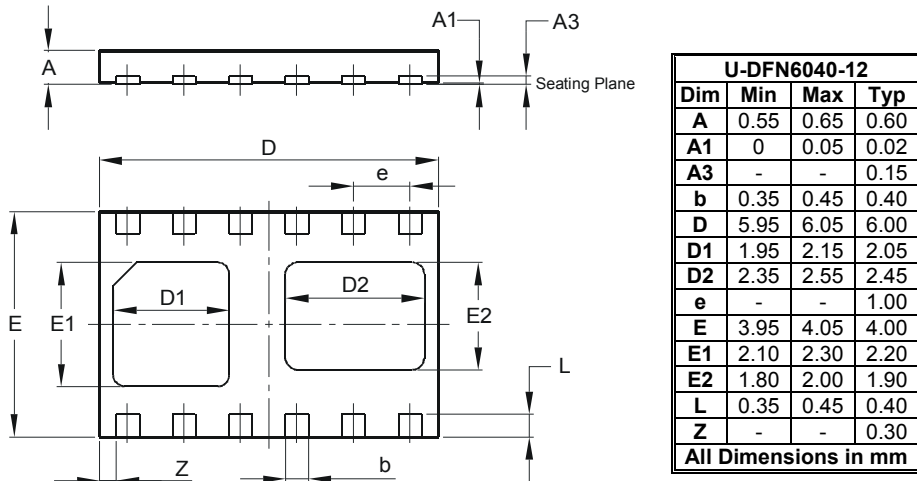
**Marking Information**

(1) U-DFN6040-12



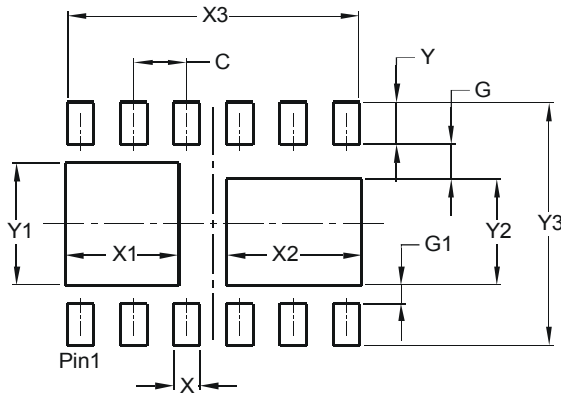
**Package Outline Dimensions** (All dimensions in mm.)

Please see AP02002 at <http://www.diodes.com/datasheets/ap02002.pdf> for latest version.



## Suggested Pad Layout

Please see AP02001 at <http://www.diodes.com/datasheets/ap02001.pdf> for the latest version.



Dimensions	Value (in mm)
<b>C</b>	0.500
<b>G</b>	0.650
<b>G1</b>	0.350
<b>X</b>	0.250
<b>X1</b>	1.075
<b>X2</b>	1.275
<b>X3</b>	2.750
<b>Y</b>	0.400
<b>Y1</b>	1.150
<b>Y2</b>	1.000
<b>Y3</b>	2.300

### IMPORTANT NOTICE

DIODES INCORPORATED MAKES NO WARRANTY OF ANY KIND, EXPRESS OR IMPLIED, WITH REGARDS TO THIS DOCUMENT, INCLUDING, BUT NOT LIMITED TO, THE IMPLIED WARRANTIES OF MERCHANTABILITY AND FITNESS FOR A PARTICULAR PURPOSE (AND THEIR EQUIVALENTS UNDER THE LAWS OF ANY JURISDICTION).

Diodes Incorporated and its subsidiaries reserve the right to make modifications, enhancements, improvements, corrections or other changes without further notice to this document and any product described herein. Diodes Incorporated does not assume any liability arising out of the application or use of this document or any product described herein; neither does Diodes Incorporated convey any license under its patent or trademark rights, nor the rights of others. Any Customer or user of this document or products described herein in such applications shall assume all risks of such use and will agree to hold Diodes Incorporated and all the companies whose products are represented on Diodes Incorporated website, harmless against all damages.

Diodes Incorporated does not warrant or accept any liability whatsoever in respect of any products purchased through unauthorized sales channel. Should Customers purchase or use Diodes Incorporated products for any unintended or unauthorized application, Customers shall indemnify and hold Diodes Incorporated and its representatives harmless against all claims, damages, expenses, and attorney fees arising out of, directly or indirectly, any claim of personal injury or death associated with such unintended or unauthorized application.

Products described herein may be covered by one or more United States, international or foreign patents pending. Product names and markings noted herein may also be covered by one or more United States, international or foreign trademarks.

This document is written in English but may be translated into multiple languages for reference. Only the English version of this document is the final and determinative format released by Diodes Incorporated.

### LIFE SUPPORT

Diodes Incorporated products are specifically not authorized for use as critical components in life support devices or systems without the express written approval of the Chief Executive Officer of Diodes Incorporated. As used herein:

A. Life support devices or systems are devices or systems which:

1. are intended to implant into the body, or
2. support or sustain life and whose failure to perform when properly used in accordance with instructions for use provided in the labeling can be reasonably expected to result in significant injury to the user.

B. A critical component is any component in a life support device or system whose failure to perform can be reasonably expected to cause the failure of the life support device or to affect its safety or effectiveness.

Customers represent that they have all necessary expertise in the safety and regulatory ramifications of their life support devices or systems, and acknowledge and agree that they are solely responsible for all legal, regulatory and safety-related requirements concerning their products and any use of Diodes Incorporated products in such safety-critical, life support devices or systems, notwithstanding any devices- or systems-related information or support that may be provided by Diodes Incorporated. Further, Customers must fully indemnify Diodes Incorporated and its representatives against any damages arising out of the use of Diodes Incorporated products in such safety-critical, life support devices or systems.

Copyright © 2014, Diodes Incorporated

[www.diodes.com](http://www.diodes.com)