

REVISIONS					
P	LTR	DESCRIPTION	DATE	DWN	APVD
	A1	REVISED PRE PCN E-17-012564	28AUG2017	JA	DM

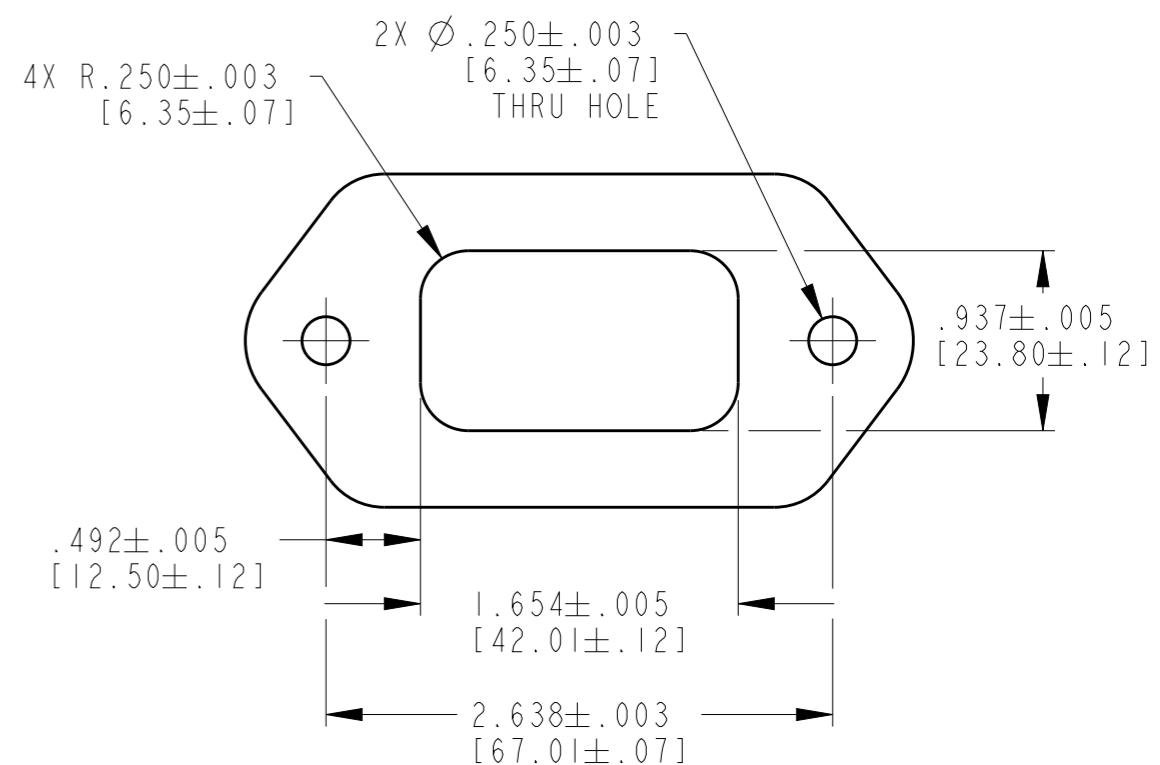
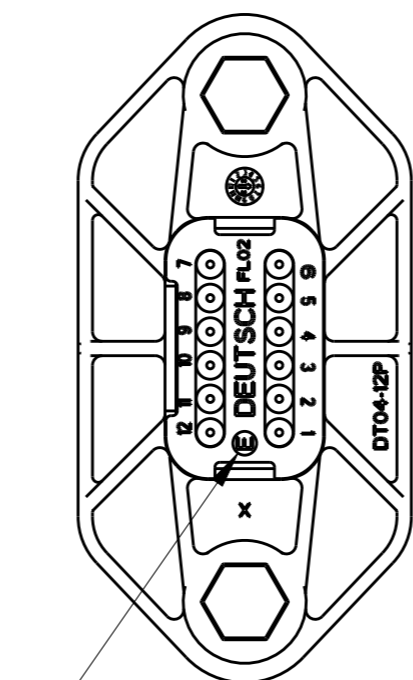
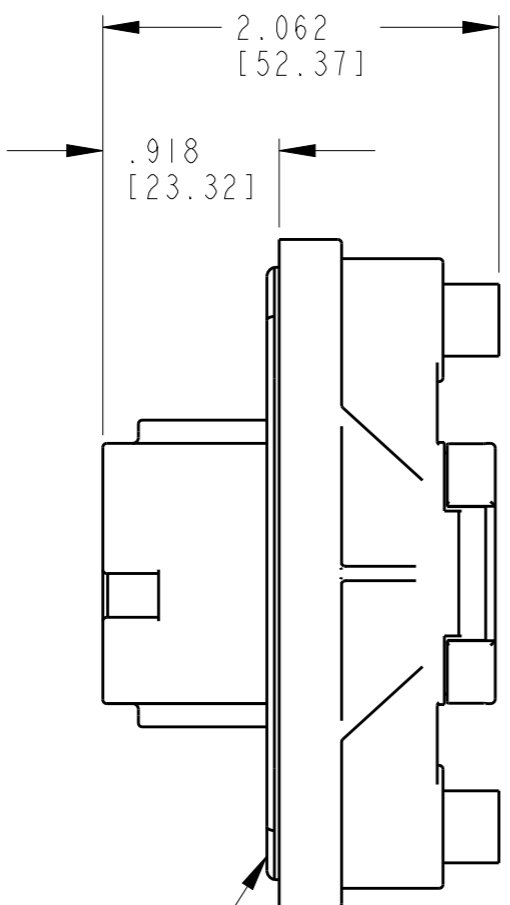
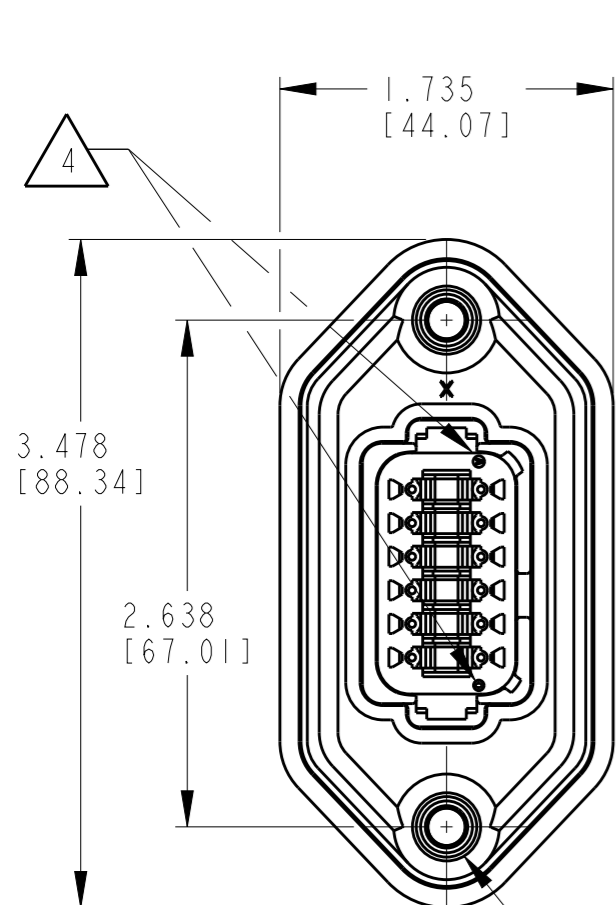

2X THREADED INSERT
 M6 X .500 DEEP
 RECOMMENDED TORQUE:
 62-88 IN-LB [7-10 N-m]

FLANGE SEAL IS INTENDED
 FOR NON-PRESSURIZED
 FLUID SPLASH ONLY

-E- SYMBOL DESIGNATES
 REDUCED DIAMETER WIRE SEAL

RECOMMENDED PANEL-CUTOUT

TE INTERNAL PN	DEUTSCH PN
DT04-12PA-FL02	DT04-12PA-FL02
DT04-12PB-FL02	DT04-12PB-FL02
DT04-12PC-FL02	DT04-12PC-FL02
DT04-12PD-FL02	DT04-12PD-FL02

CONTACT SIZE	MIN. INSUL. O.D.	MAX. INSUL. O.D.	WIRE RANGE [mm ²] REF ONLY
16	.053 [1.35]	.120 [3.05]	14-20 AWG [2.5-0.5]

4 DATE CODE: MONTH IS REPRESENTED BY SEQUENTIAL ALPHA CHARACTERS. EX: A = JANUARY, YEAR IS REPRESENTED BY LAST NUMERICAL DIGIT. EX: 0 = 2010

3 MATERIAL: HOUSING, CAP: PA66 GF15 (SEE SHEET 2 FOR COLOR)
 GROMMET: FKM (BLACK)
 GASKET: VMQ (RED-ORANGE)
 INSERTS: STAINLESS STEEL

2. THIS RECEPTACLE MATES WITH DT06-12SX-XXXX PLUG.
 (X = KEY ARR; XXXX = ALL MODIFICATIONS)
 CONSULT FACTORY FOR MODIFICATIONS.

1 FOR CONTACTS AND WIRE PERFORMANCE AND APPLICATION CHARACTERISTICS, SEE ENVELOPE DRAWING 0425-015-0000.

NOTES: UNLESS OTHERWISE SPECIFIED

THIS DRAWING IS A CONTROLLED DOCUMENT.		DWN R. MESSENGER 30AUG2011		
DIMENSIONS: in [mm]		CHK B. BYFORD 09FEB2012		
TOLERANCES UNLESS OTHERWISE SPECIFIED:		APVD S. BEARD 09FEB2012	NAME 12 WAY RECEPTACLE WITH ENHANCED KEY FLANGE, VITON SEAL DT SERIES	
0 PLC ±		PRODUCT SPEC 108-151009	SIZE A3	
1 PLC ±		APPLICATION SPEC 0425-017-0000	CAGE CODE 4AFU8	DRAWING NO. DT04-12PX-FL02
2 PLC ±		WEIGHT 78g	RESTRICTED TO -	
3 PLC ±.025 [0.64]		CUSTOMER DRAWING	SCALE 1:2	SHEET 1 OF 2
4 PLC ±			REV A1	
ANGLES ±0° 30' 0"				
FINISH				

REVISIONS

P	LTR	DESCRIPTION	DATE	DWN	APVD
-		SEE SHEET 1	-	-	-

DT04-12PA-FL02
KEY ARR. -A-
COLOR: GRAY

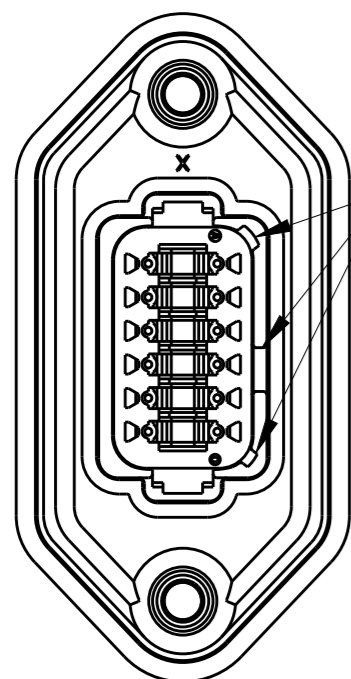

--A- KEYWAYS

DT04-12PB-FL02
KEY ARR. -B-
COLOR: BLACK

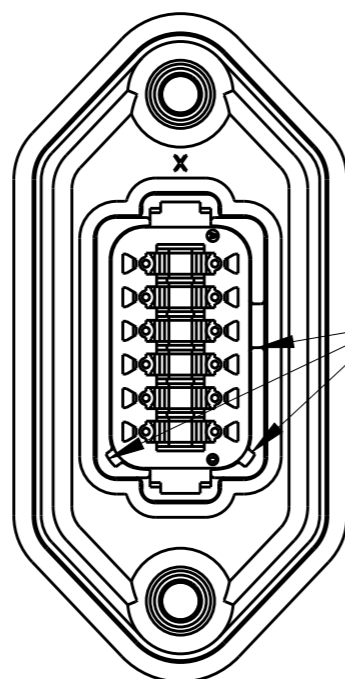

--B- KEYWAYS

DT04-12PC-FL02
KEY ARR. -C-
COLOR: GREEN

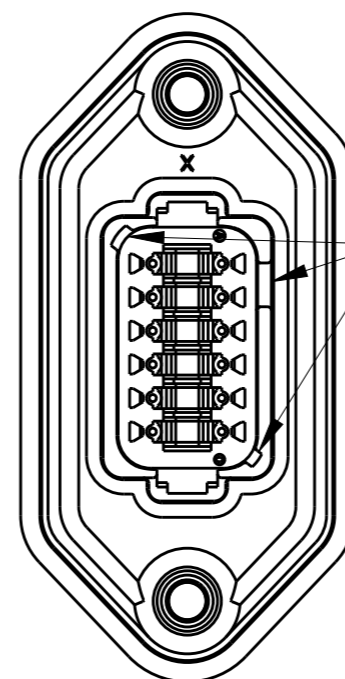

--C- KEYWAYS

DT04-12PD-FL02
KEY ARR. -D-
COLOR: BROWN

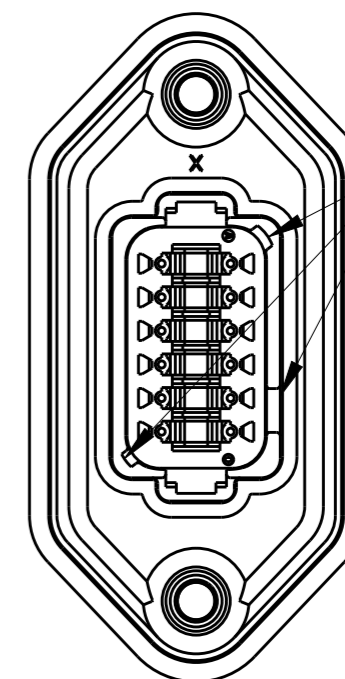

--D- KEYWAYS

THIS DRAWING IS A CONTROLLED DOCUMENT.

DIMENSIONS:
in [mm]

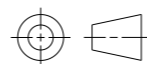

TOLERANCES UNLESS OTHERWISE SPECIFIED:

0 PLC	±
1 PLC	±
2 PLC	±
3 PLC	±.025
4 PLC	±
ANGLES	±0° 30' 0"

FINISH

DWN 21AUG2017
R. MESSENGER

CHK 09FEB2012
B. BYFORD

APVD 09FEB2012
S. BEARD

PRODUCT SPEC
108-151009

APPLICATION SPEC
0425-017-0000

WEIGHT
78g

CUSTOMER DRAWING



TE Connectivity

NAME
12 WAY RECEPTACLE
WITH ENHANCED KEY FLANGE, VITON SEAL
DT SERIES

SIZE A3	CAGE CODE 4AFU8	DRAWING NO DT04-12PX-FL02	RESTRICTED TO -
------------	--------------------	------------------------------	--------------------

SCALE 1:2 SHEET 2 OF 2 REV A1