

Future Technology Devices International Limited Datasheet CleO35 Module



1 Introduction

The *CleO35* is a smart TFT display shield for Arduino. It includes a 3.5 inch 320x480 pixel TFT LCD panel with resistive touch, PWM audio output with in-built speaker amplifier for better audio quality

These smart TFT display shields can be easily programmed by almost anyone to give professional looking HMI / GUI's with no prior knowledge of complex graphics programming or mathematics.

1.1 Features

The *CleO35* utilises the FTDI FT903 low power MCU to bridge between the Arduino and fast interface accessories such as camera and SD Card input. For a full list of the FT903's features please see the [FT90X datasheet](#). In addition, the *CleO35* has the following features:

- Landscape and portrait modes supported
- In built FTDI FT810 embedded video engine (EVE) graphic controller
- Anti-Aliased graphics throughout for much finer image quality with no "jaggies".
- Ready to use LCD module with resistive touch in panel mountable bezel.
- Micro SD card socket support.
- In built 8M Byte Eflash memory
- USB DFU port for firmware updates
- Support camera interface
- PWM audio supported and in built speaker amplifier
- Designed as Arduino and *NerO* shield
- Compatible with FTDI *CleO*-RIO, *CleO*-Camera and *CleO*-Speaker.
- CE and FCC certified

Neither the whole nor any part of the information contained in, or the product described in this manual, may be adapted or reproduced in any material or electronic form without the prior written consent of the copyright holder. This product and its documentation are supplied on an as-is basis and no warranty as to their suitability for any particular purpose is either made or implied. Future Technology Devices International Ltd will not accept any claim for damages howsoever arising as a result of use or failure of this product. Your statutory rights are not affected. This product or any variant of it is not intended for use in any medical appliance, device or system in which the failure of the product might reasonably be expected to result in personal injury. This document provides preliminary information that may be subject to change without notice. No freedom to use patents or other intellectual property rights is implied by the publication of this document. Future Technology Devices International Ltd, Unit 1, 2 Seaward Place, Centurion Business Park, Glasgow G4 1 1HH United Kingdom. Scotland Registered Company Number: SC 136640

2 Ordering Information

Part No.	Description
CleO35A	<i>CleO35</i> module, with FPC/FFC 50 LCD connector, 3.5 inch TFT LCD display panel preinstalled, with resistive touch. Black bezel.
CleO-RIO1	Arduino Shield for users to stack Arduino board on bottom of CleO35.
CleO-CAM1	A camera plug-in module for CleO35.
CleO-SPK1	A speaker enclosure with connecting wires to CleO35.

3 Program Support

- The demo applications are provided for *CleO35* modules by FTDI. Visit FTDI's website at <http://www.ftdichip.com/Products/Modules/CleO.htm> for more information.

Table of Contents

1	Introduction	1
1.1	Features	1
2	Ordering Information	2
3	Program Support	2
4	Module Hardware Feature	5
4.1	Power Supply.....	6
4.2	Micro-controller	6
4.3	Micro SD Interface	7
4.4	LCD Interface.....	7
4.5	Camera Interface	10
4.6	Audio Output	11
4.7	SPI Slave Interface	12
4.8	External IO Pin	13
4.9	Power and Program Interface.....	14
5	Devices Characteristics and Ratings.....	15
5.1	Electrical Specification	15
5.2	Display Specification	15
5.3	Optical Specification.....	16
6	Board Schematic.....	18
7	Block Diagram	21
8	Mechanical Dimensions	22
8.1	<i>CleO35</i> Module Dimensions.....	22
8.2	Bezel Drawing.....	23
9	Contact Information.....	24
Appendix A – References		25
Document References		25
Acronyms and Abbreviations		25
Appendix B - List of Figures and Tables		26

List of Figures	26
List of Tables	26
Appendix C – Revision History.....	27

4 Module Hardware Feature

The dimensions of the *CleO35* module are 101.4 mm x 73 mm X15mm. See Figure 1 for all the hardware features.

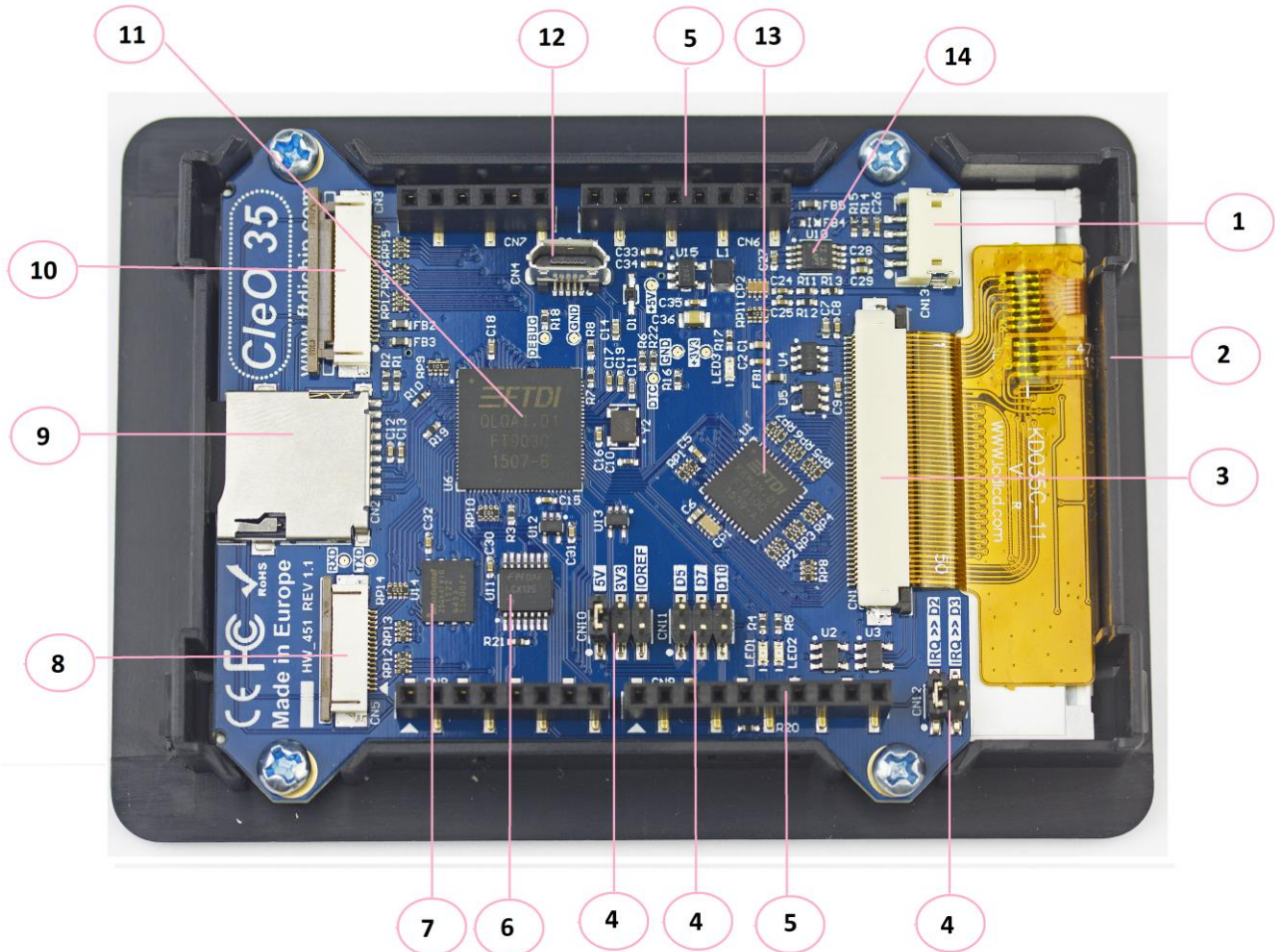

Figure 1 – CleO35 Bottom View

Key Features:

- | | |
|---|---------------------------------|
| 1 Speaker out / Line in | 2 Plastic Bezel |
| 3 3.5 in HVGA TFT I/F + Resistive Touch | 4 Arduino Configuration Jumpers |
| 5 Arduino I/F | 6 Level Shifter |
| 7 8M Byte E-Flash | 8 FT903 IO Expansion |
| 9 MicroSD Card Socket | 10 Camera Interface |
| 11 FT903 MCU | 12 USB DFU Connector |
| 13 FT810 GPU | 14 Audio Amplifier |

4.1 Power Supply

The *CleO35* module receives power externally. Users can combine the module with the FCC/CE certified *NerO* or Arduino UNO and draw power from those board supplies. For details of the *NerO* module, refer to [FTDI-NerO](#) for more Information.

Alternatively, the on-board USB connector, **CN4** which is primarily for debug purpose and DFU firmware upgrade may also supply power.

Once the 5V supply is applied, a Red LED power indicator will be turned on. A step down regulator **U15** will step down the 5V to 3.3V. The 3.3V supply will serve all peripherals of the FT903 microcontroller.

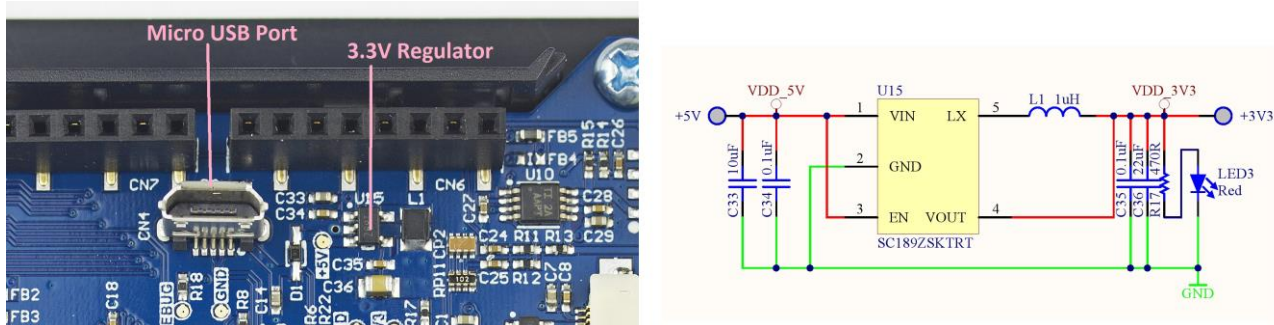

Figure 2 - Power Supply

4.2 Micro-controller

The FT903Q 100-pin QFN microcontroller which is provided on the board belongs to 32-bit FT90X Super Bridging Microcontroller family from FTDI Chip. For details of the FT903Q Microcontroller, refer to the [FT90X datasheet](#).



Figure 3 - Micro-Controller

4.3 Micro SD Interface

A Micro SD card slot is provided on *CleO35* supporting two standards capacity card types:

- Secure Digital (SD) standard – Up to 2GB SD memory card
- Secure Digital High Capacity (SDHC) standard – Over 2GB-32GB SDHC memory card

The SD host controller is compatible with the standard specification V3.0. It supports up to 25MHz SD clock speed. In the *CleO35* design, the physical interface supports 4-bit SD bus mode and card detection.

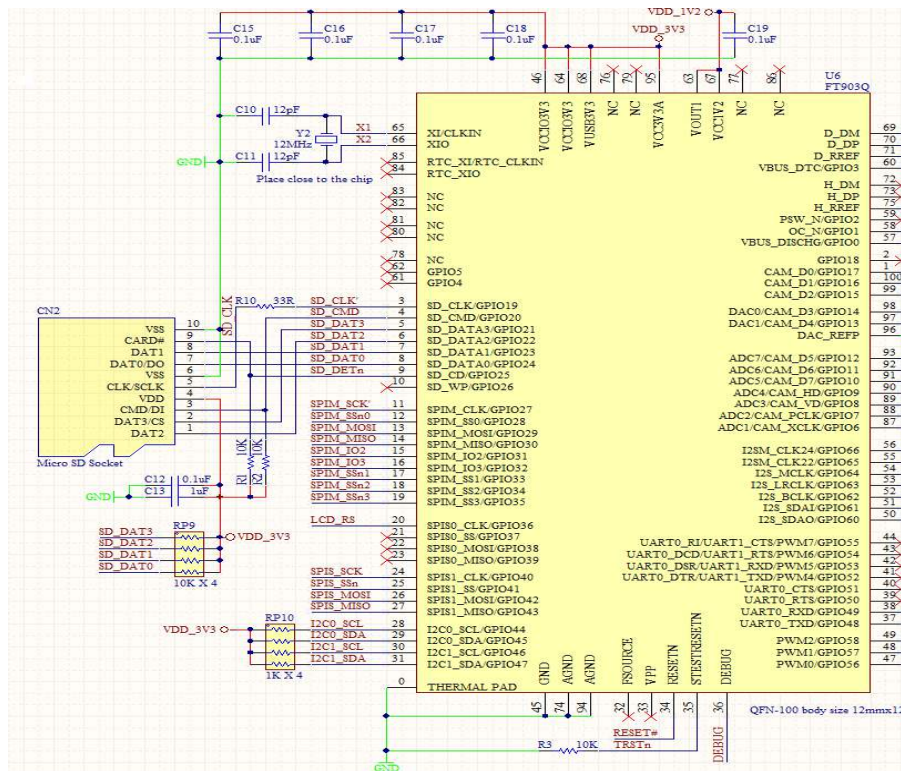

Figure 4 - MicroSD Interface

4.4 LCD Interface

In the *CleO35* design, a 3.5 inch TFT LCD with resistive touch is supported. The FT810Q 48pin VQFN graphics controller IC with integrated touch and audio belongs to FTDI’s EVE series. For further details of the FT810Q EVE graphics controller, refer to the [FT81X datasheet](#).

The 3.5 inch LCD is connected through the 50 pin FPC/FFC connector **CN1**. See Table 1 for the LCD connector pinout.

Pin No	Name	Description
1	GND	Ground
2	LEDA	Backlight LED Anode
3	LEDK	Backlight LED cathode

Pin No	Name	Description
4	LEDK	Backlight LED cathode
5	LEDK	Backlight LED cathode
6	LEDK	Backlight LED cathode
7	LEDK	Backlight LED cathode
8	LEDK	Backlight LED cathode
9	GND	Ground
10	GND	Ground
11	VDD3V3	LCD VCC supply
12	VDD3V3	LCD VCC supply
13	LCD_RST	Reset
14	SPIM_SS _{n1}	SPI chip select
15	LCD_RS	RS
16	SPIM_SCK	SPI clock
17	GND	ground
18	SPIM_MOSI	Master output slave input
19	LCD_SDO	Master input slave output
20	LCD_B2	Bit2 of blue RGB signal
21	LCD_B3	Bit3 of blue RGB signal
22	LCD_B4	Bit4 of blue RGB signal
23	LCD_B5	Bit5 of blue RGB signal
24	LCD_B6	Bit6 of blue RGB signal
25	LCD_B7	Bit7 of blue RGB signal
26	LCD_G2	Bit2 of green RGB signal
27	LCD_G3	Bit3 of green RGB signal
28	LCD_G4	Bit4 of green RGB signal
29	LCD_G5	Bit5 of green RGB signal
30	LCD_G6	Bit6 of green RGB signal
31	LCD_G7	Bit7 of green RGB signal
32	LCD_R2	Bit2 of red RGB signal
33	LCD_R3	Bit3 of red RGB signal
34	LCD_R4	Bit4 of red RGB signal
35	LCD_R5	Bit5 of red RGB signal
36	LCD_R6	Bit6 of red RGB signal
37	LCD_R7	Bit7 of red RGB signal
38	DE	Data enable

Pin No	Name	Description
39	DCLK	Pixel clock
40	HSYNC	LCD horizontal sync
41	VSYNC	LCD vertical sync
42	-	IM2
43	-	IM1
44	-	IM0
45	GND	ground
46	YP	Y Top electrode of resistive touch
47	XM	X left electrode of resistive touch
48	YM	Y bottom electrode of resistive touch
49	XP	X right electrode of resistive touch
50	GND	ground

Table 1 - LCD Connector Pin Out

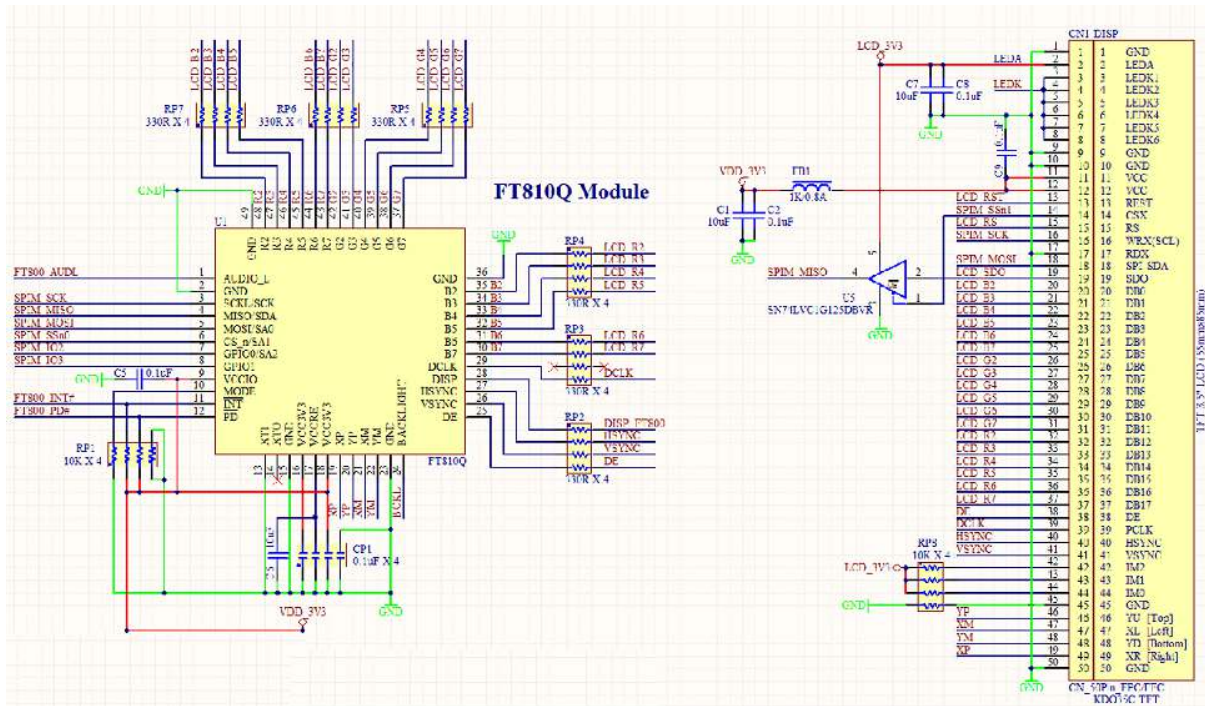

Figure 5 - LCD Interface

4.5 Camera Interface

The *CleO35* has a camera module interface, via a 24-pin 0.5mm pitch FFC/FPC, bottom contact connector, **CN3**. In this design, support is provided for an OmniVision OV2640 camera module. A readymade camera module (CleO-CAM1A) can be purchased from FTDI. Support for further camera modules may be added in the future. Please visit the [FTDI](http://www.ftdi.com) website for more information.

See table 2 for the Camera interface pinout

Pin No	Name	Description
1	GND	Ground
2	GND	Ground
3	I2C0_SDA	I2C serial bus, data line
4	CAM_5V	5V power supply
5	I2C0_SCL	I2C serial bus, clock line
6	RESET#	Hardware reset, active low
7	CAM_VD	Camera vertical sync input
8	CAM_PWDN	Camera module power down signal, active high
9	CAM_HD	Camera horizontal reference input
10	CAM_3V3	3.3V power supply
11	CAM_3V3	3.3V power supply
12	CAM_D7	Camera data line, Bit 7
13	CAM_XCLK	Camera external clock output
14	CAM_D6	Camera data line, Bit 6
15	GND	Ground
16	CAM_D5	Camera data line, Bit 5
17	CAM_PCLK	Camera pixel clock input
18	CAM_D4	Camera data line, Bit 4
19	CAM_D0	Camera data line, Bit 0
20	CAM_D3	Camera data line, Bit 3
21	CAM_D1	Camera data line, Bit 1
22	CAM_D2	Camera data line, Bit 2
23	CAM_5V	5V power supply
24	PWM0	Pulse width modulation

Table 2 - Camera Connector Pin Out

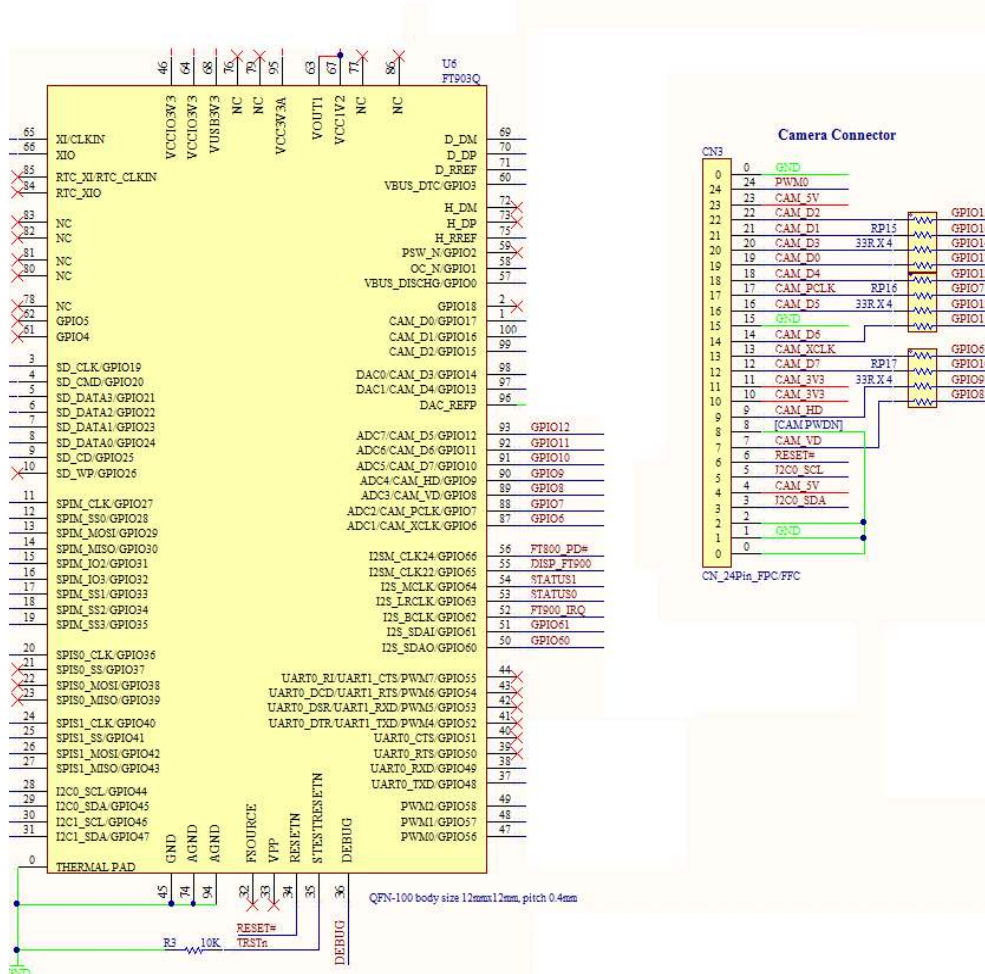

Figure 6 - Camera Interface

4.6 Audio Output

CleO35 supports a mono speaker output through CN13. Maximum output power, can drive up to 8 OHM, 1 Watt speaker driver. A readymade speaker module (CleO-SPK1) is also available from FTDI; visit the [FTDI Chip](http://www.ftdi.com) website for more information.

An alternative, mono line-in audio input is also provided on CN13. Users can drive in their own audio source to the on board power amplifier. See the Table 3 for the pin list for CN13.

Pin No	Pin Name	Description
1	SP-	Speaker out negative
2	SP+	Speaker out positive
3	GND	Ground
4	EXT_AUD	Ext audio line in

Table 3 - Pin List of CN3

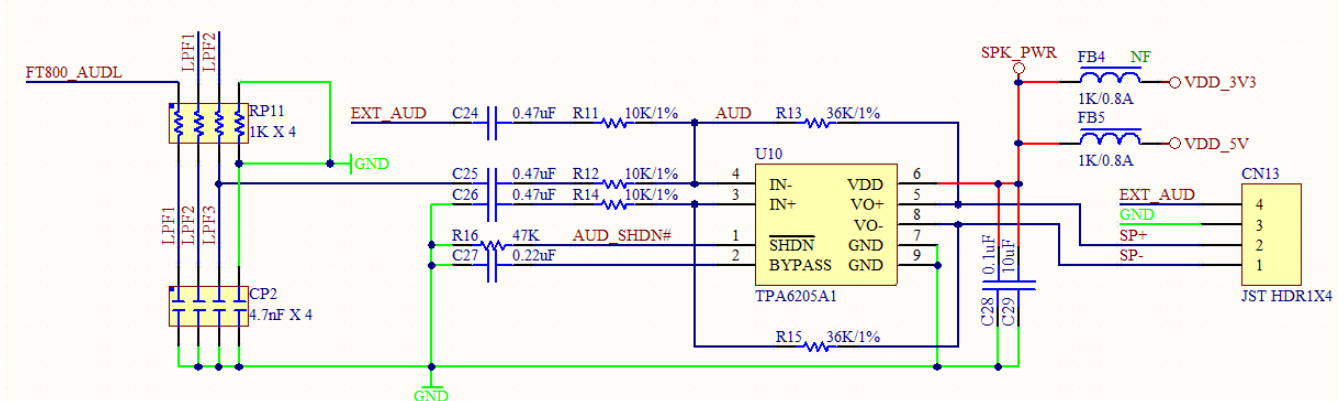

Figure 7 - Speaker Amplifier Circuitry

4.7 SPI Slave Interface

The *CleO35* has a SPI slave interface that supports single and dual (2 data lines) SPI data transfer modes. This interface supports both 5V, 3.3V and user defined output levels. The user defined interface levels must be between 3V (min) to 5.5V (max). The power selection jumper is through **CN10**.

Pin Number	Description
1-2	5V SPI interface
3-4	3.3V SPI interface
5-6	SPI interface voltage level follows user setting(IOREF)

Table 4 - CN10 Jumper Selection

There are chip select (CS) jumper selections on **CN11**. The user has 3 options to choose for their connection.

Pin Number	Description
1-2	SPI chip select from D5(option 1)
3-4	SPI chip select from D7(option 2)
5-6	SPI chip select from D10(option 3)

Table 5 - CN11 Jumper Selection

For the SPI Slave interface, there are two connectors for the user to interface with the master side.

- The **CN9** – 1X10 position 2.54mm pitch female header
- The **CN8** – 1X8 position 2.54mm pitch female header

Pin Number	Name	Description
1	-	No connection
2	-	No connection
3	D10	SPI Chip select option3
4	MOSI	SPI data from master side

Pin Number	Name	Description
5	MISO	SPI data to master side
6	SCK	SPI clock
7	GND	Ground
8	-	No connection
9	-	No connection
10	-	No connection

Table 6 - CN9 Pin List

Pin Number	Name	Description
1	-	No connection
2	-	No connection
3	D2	FT903 Interrupt request out option 1
4	D3	FT903 Interrupt request out option 2
5	-	No connection
6	D5	SPI Chip select option1
7	-	No connection
8	D7	SPI Chip select option2

Table 7 - CN8 Pin List

4.8 External IO Pin

There are extra features provided on **CN5**, 16 position 0.5mm pitch FFC/FPC connector. Users can connect to external feature boards through this connector.

See Table 8 for all the extra features assigned to each pin.

Pin Number	Name	Description
1	GPIO61	General purpose IO 61
2	GPIO60	General purpose IO 60
3	PWM2	Pulse Width Modulation 2
4	PWM1	Pulse Width Modulation 1
5	VDD3V3	3.3V supply
6	GND	Ground
7	I2C1_SCL	I2C1 Serial Clock
8	I2C1_SDA	I2C1 Serial Data
9	UART0_RXD	UART0 receive

10	UART0_TXD	UART0 transmit
11	VDD3V3	3.3V supply
12	GND	Ground
13	SPIM_MISO	SPI3 Master Input
14	SPIM_MOSI	SPI3 Master Output
15	SPIM_SSn3	SPI3 Chip Select
16	SPIM_SCK	SPI3 Clock Line

Table 8 - CN5 Pin List

There is a jumper selection for the FT903 interrupt request through **CN12**. Users have 2 option to choose from.

Pin Number	Description
1-2	Connect to Arduino/NerO MCU int0(D2)
3-4	Connect to Arduino/NerO MCU int1(D3)

Table 9 - CN12 Jumper Selection

4.9 Power and Program Interface

The power interface **CN6**, 1X8 position 2.54mm pitch female header, may be driven by NerO or an Arduino UNO.

Users can use the USB connector **CN4** for FT903 firmware upgrades. For the details of the tool operation, refer to [AN_325_FT900_Tool_Chain_Installation_Guide](#).

Pin Number	Name	Description
1	NC	NC
2	IOREF	IO reference voltage
3	RESET	FT903 reset pin
4	-	No connection
5	VDD5V	5V supply
6	GND	ground
7	GND	ground
8	-	No connection

Table 10 - CN6 Pin List

5 Devices Characteristics and Ratings

5.1 Electrical Specification

Parameter	Value	Unit	Conditions
Storage Temperature	-30°C to 80°C	Degrees C	
Ambient Operating Temperature (Power Applied)	-20°C to 70°C	Degrees C	

Table 11 - Temperature Parameter

DC Characteristics (Ambient Temperature = -20°C to +70°C)

Parameter	Description	Minimum	Typical	Maximum	Units	Conditions
V _{bus}	USB power supply	4.75		5.25	V	
V _{DC}	DC power supply	4.75		5.25	V	External source
I _{usb}	USB power supply current			500	mA	
I _{DC}	DC Supply Current			500	mA	
I _{idle}	USB current in idle mode		140		mA	With LCD and backlight on
V _{io}	3.3 V _{io} voltage reference	3.0	3.3	3.6	V	
V _{ih}	Input high voltage	2				
V _{il}	Input low voltage			0.8		
V _{oh}	output high voltage	2.4				
V _{ol}	output low voltage			0.4		

Table 12 - Operating Voltage and Current

5.2 Display Specification

Item	Spec	Units	Notes
Display area(AA)	49.0(H) * 73.4(V)	mm	3.5 inch diagonal
Driver Element	TFT active matrix	mA	
Display Colours	262K	-	
Number of Pixels	320(RGB)*480	dots	
Pixel pitch	0.051(H) * 0.051(V)	mm	

Item	Spec	Units	Notes
Viewing Angle	6:00	o'clock	Portrait view
Display mode	Transmissive/ Normally White	-	
LCD Luminance	100	cd/m ²	
Touch screen	resistive	-	

Table 13 - Display Specifications

5.3 Optical Specification

Item	Symbol	Conditions	Specifications			Unit	Note	
			Min.	Typ.	Max.			
Transmittance	T%	Viewing normal angle $\theta_x = \theta_y = 0^\circ$		5.5		%	All left side data are based on CMO's following condition – 1. LC Mode: TN 2. Light Source : CMO LED BLU 3. Film : Linear Polarizer+WV (Nitto NPF-TEG1424DU) 4. Machine : DMS 803	
Contrast Ratio	CR			500	-	-		
Response Time	T_{on}		-	5		ms		
	T_{off}	-	15		ms			
Viewing Angle	Hor.	θ_{x+}	-	70	-	deg		
		θ_{x-}	-	70	-			
	Ver.	θ_{y+}	-	60	-			
		θ_{y-}	-	60	-			
Chromaticity	Red	X_R	0.611	0.641	0.671	-		Under C light Simulation CG : NTSC 60%
		Y_R	0.290	0.320	0.350	-		
	Green	X_G	0.270	0.300	0.330	-		
		Y_G	0.536	0.566	0.596	-		
	Blue	X_B	0.104	0.134	0.164	-		
		Y_B	0.098	0.128	0.158	-		
	White	X_W	0.267	0.297	0.327	-		
		Y_W	0.301	0.331	0.361	-		

*Note (1) Definition of Contrast Ratio (CR):

The contrast ratio can be calculated by the following expression.

$$\text{Contrast Ratio (CR)} = L_{63} / L_0$$

L63: Luminance of gray level 63

L 0: Luminance of gray level 0

$$CR = CR (5)$$

CR (X) is corresponding to the Contrast Ratio of the point X at Figure in Note (5).

*Note (2) Definition of Response Time (T_{on} , T_{off}):

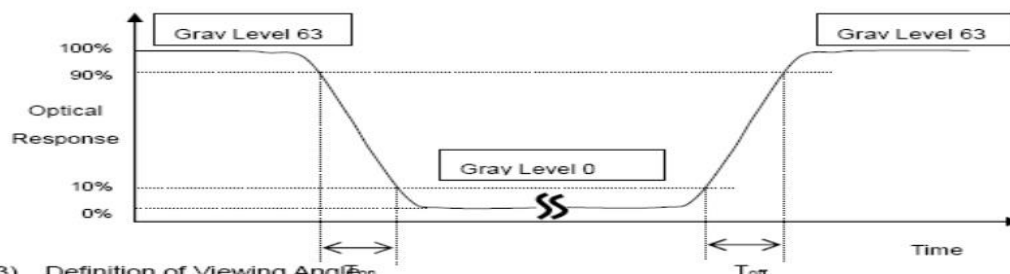

*Note(3) Definition of Viewing Angle

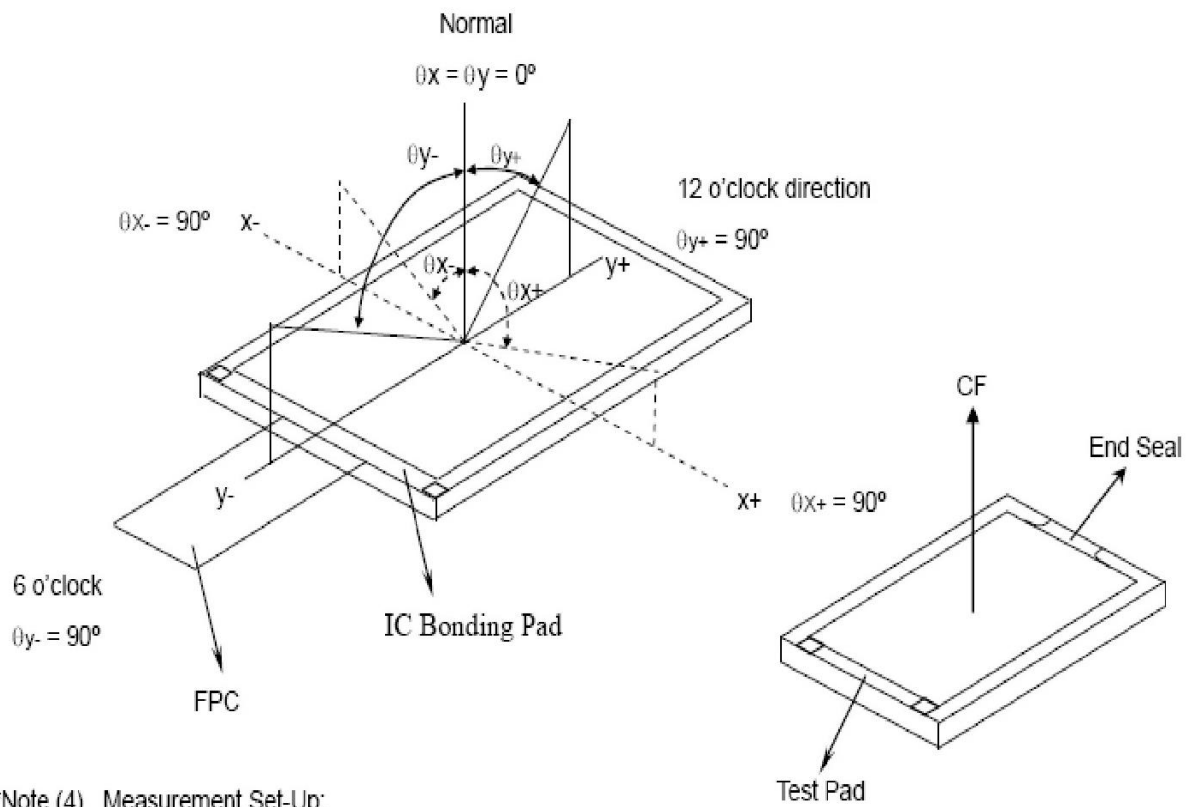

*Note (4) Measurement Set-Up:

The LCD module should be stabilized at a given temperature for 20 minutes to avoid abrupt temperature change during measuring. In order to stabilize the luminance, the measurement should be executed after lighting Backlight for 20 minutes in a windless room.

Figure 8 - 3.5 inch TFT Optical Specifications

6 Board Schematic

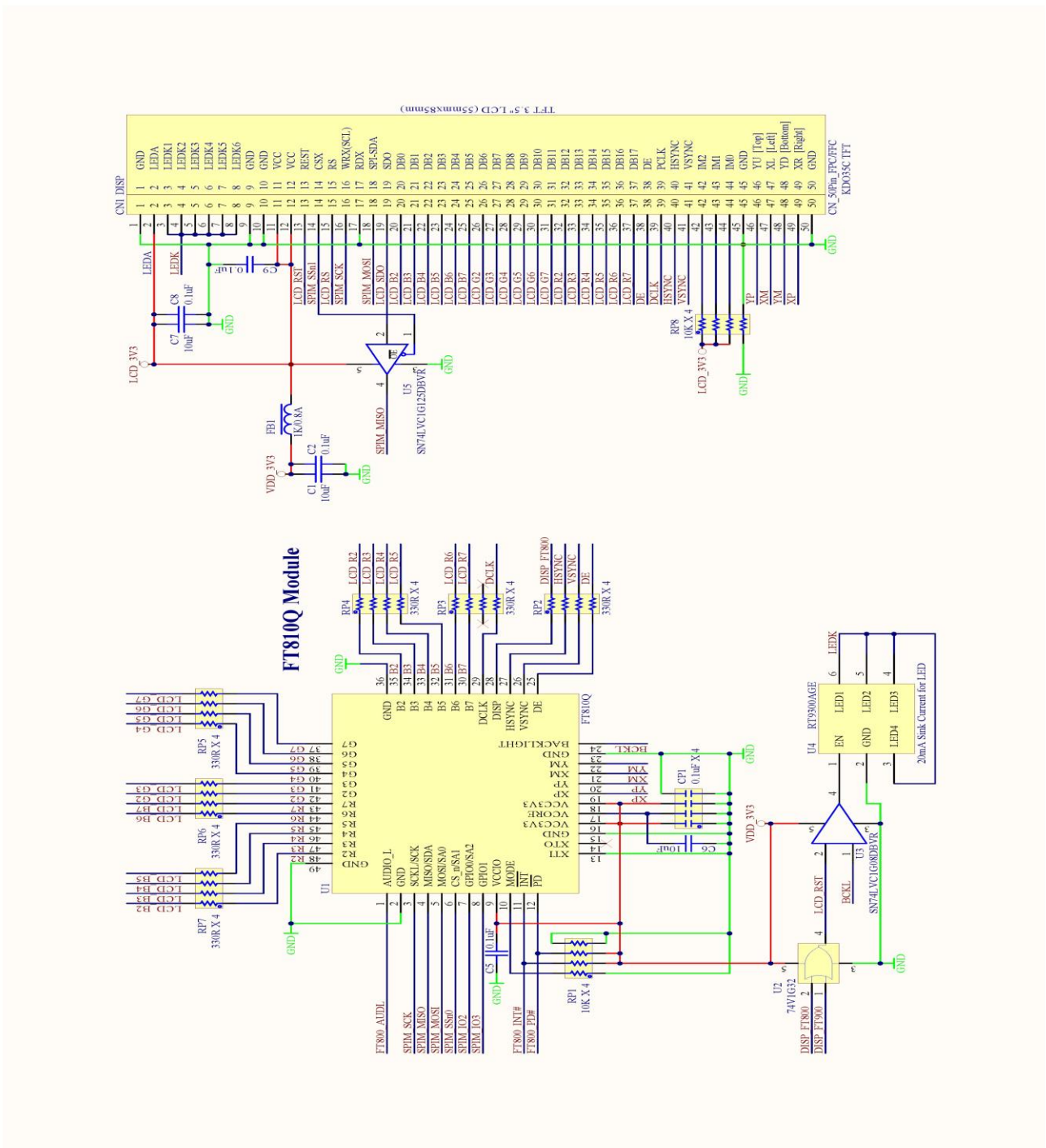

Figure 9 - Sheet1 - FT810Q Connection

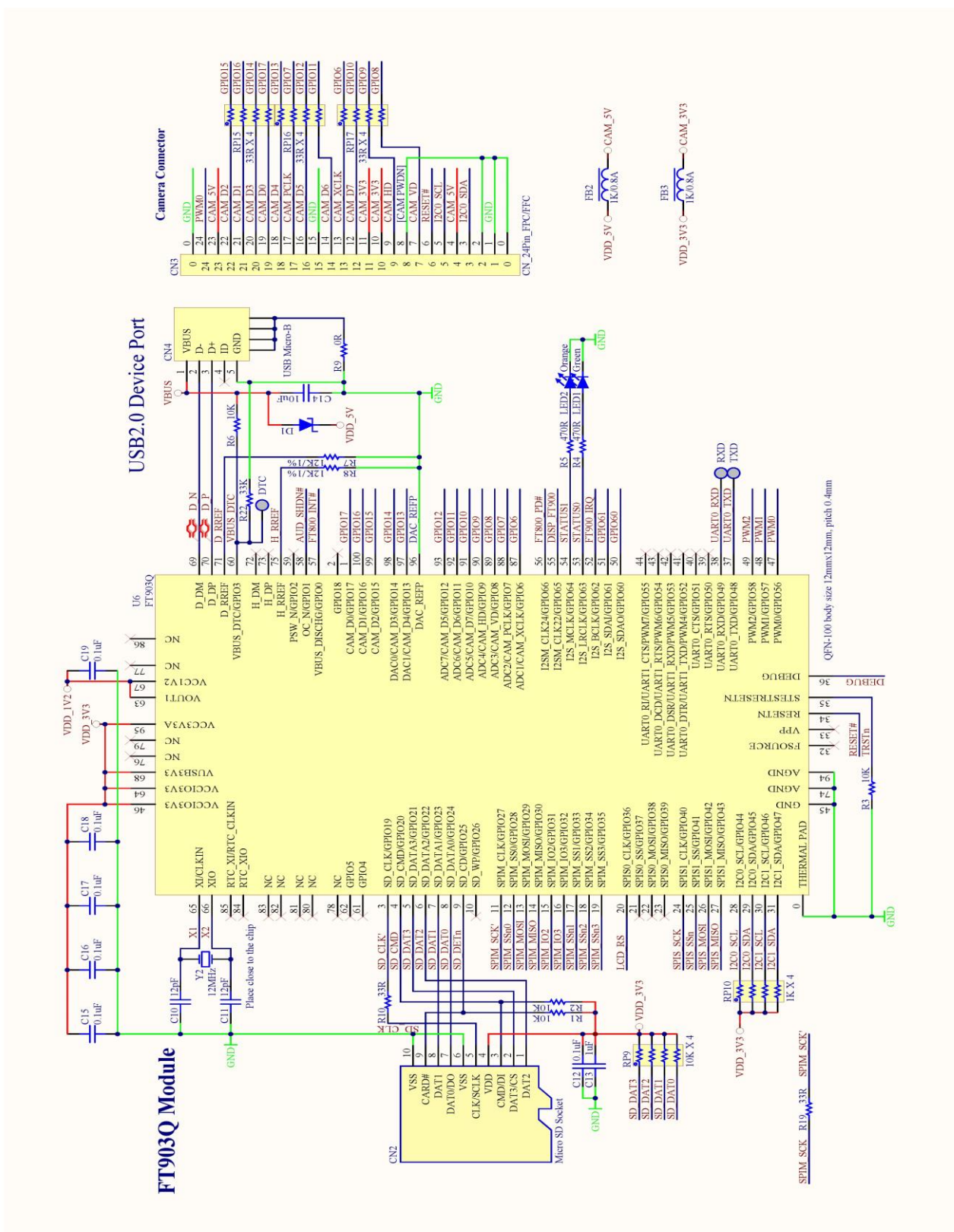

Figure 10 - Sheet2 - FT903Q Connection

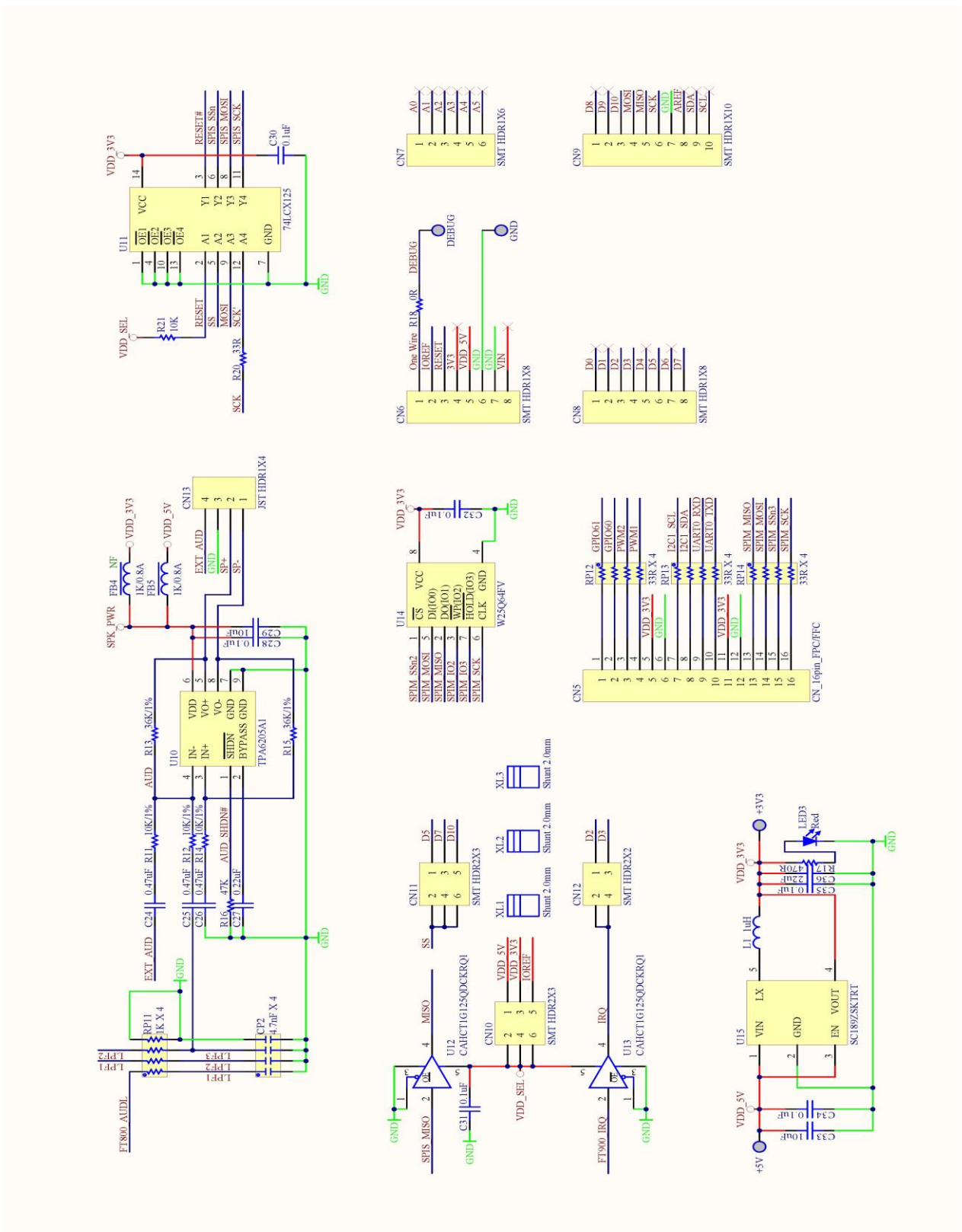

Figure 11 - Sheet3 - Power and Connectors

7 Block Diagram

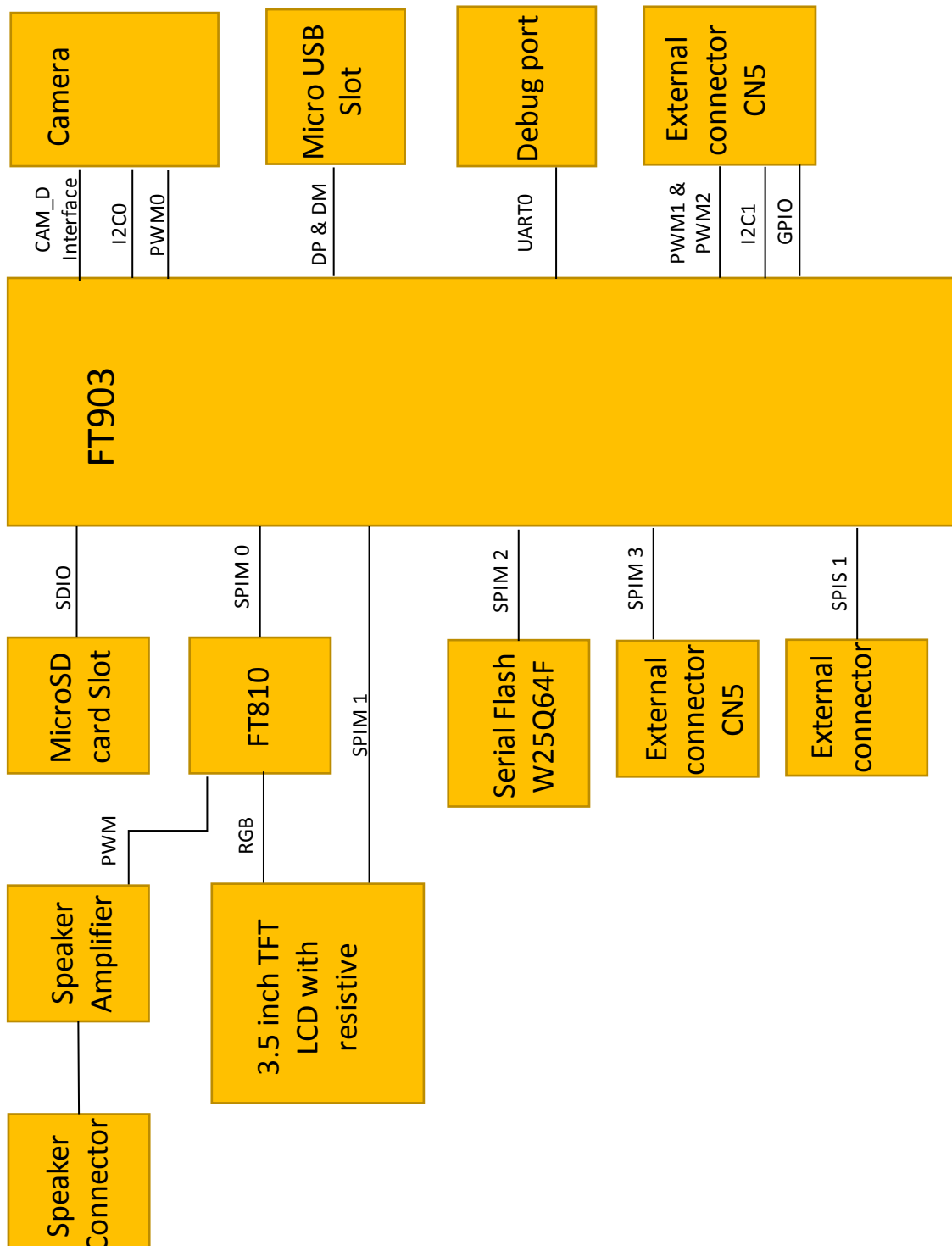

Figure 12 - CleO35 Block Diagram

8 Mechanical Dimensions

8.1 CleO35 Module Dimensions

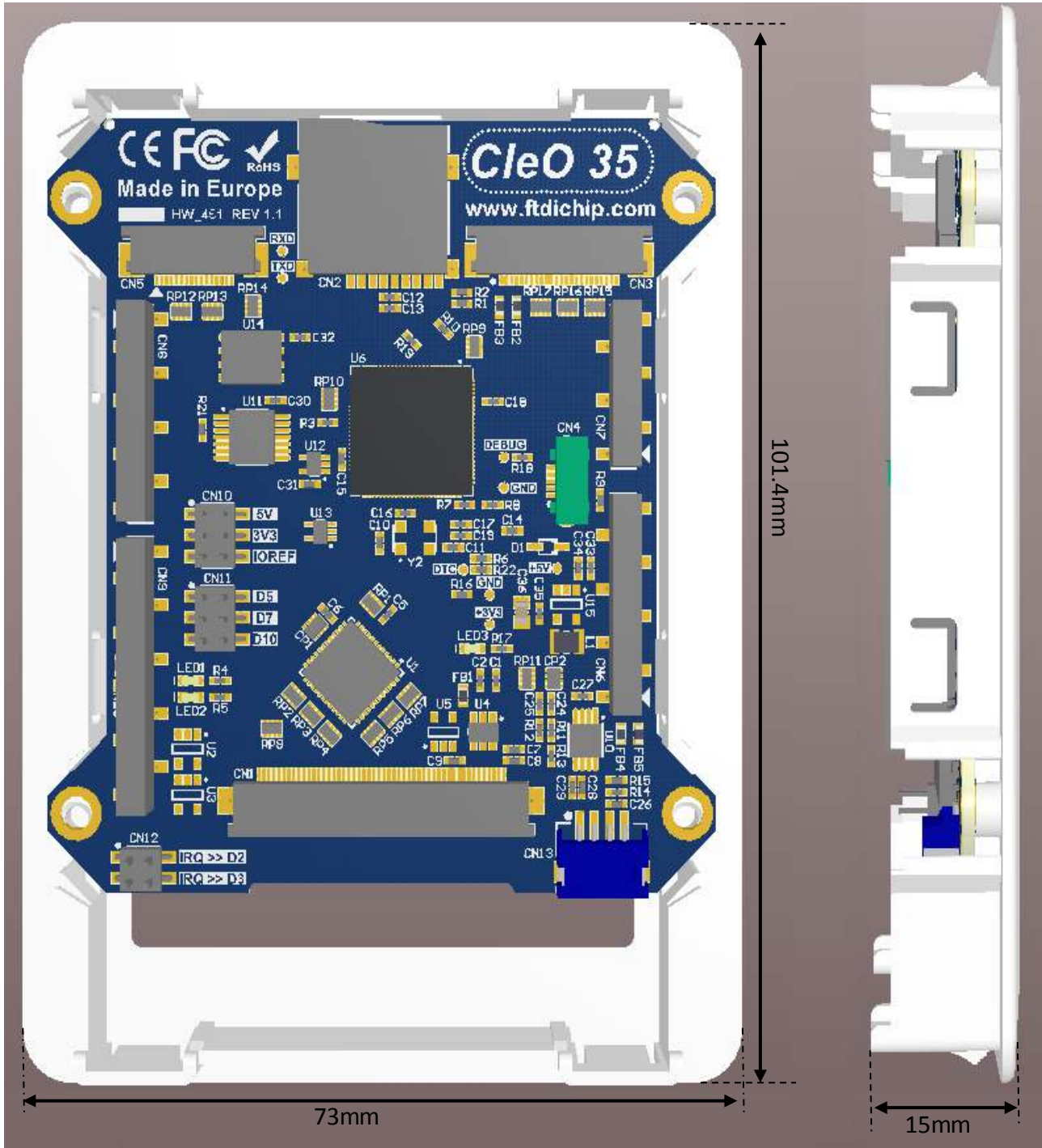

Figure 13 - Cleo35 Module Dimensions

8.2 Bezel Drawing

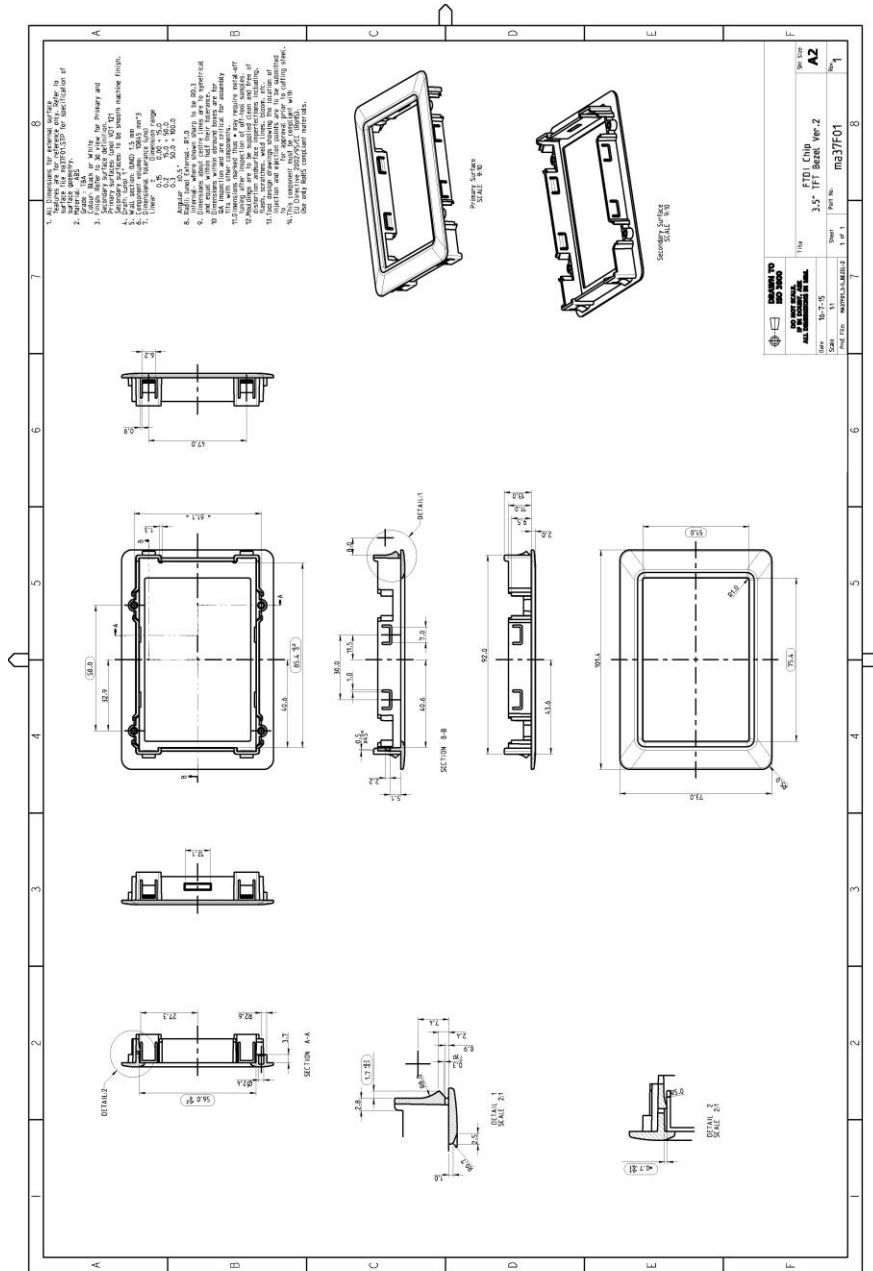

Figure 14 - CleO35 Bezel Drawing

9 Contact Information

Head Office – Glasgow, UK

Future Technology Devices International Limited
Unit 1, 2 Seaward Place, Centurion Business Park
Glasgow G41 1HH
United Kingdom
Tel: +44 (0) 141 429 2777
Fax: +44 (0) 141 429 2758

E-mail (Sales) sales1@ftdichip.com
E-mail (Support) support1@ftdichip.com
E-mail (General Enquiries) admin1@ftdichip.com

Branch Office – Tigard, Oregon, USA

Future Technology Devices International Limited (USA)
7130 SW Fir Loop
Tigard, OR 97223-8160
USA
Tel: +1 (503) 547 0988
Fax: +1 (503) 547 0987

E-mail (Sales) us.sales@ftdichip.com
E-mail (Support) us.support@ftdichip.com
E-mail (General Enquiries) us.admin@ftdichip.com

Branch Office – Taipei, Taiwan

Future Technology Devices International Limited (Taiwan)
2F, No. 516, Sec. 1, NeiHu Road
Taipei 114
Taiwan, R.O.C.
Tel: +886 (0) 2 8797 1330
Fax: +886 (0) 2 8751 9737

E-mail (Sales) tw.sales1@ftdichip.com
E-mail (Support) tw.support1@ftdichip.com
E-mail (General Enquiries) tw.admin1@ftdichip.com

Branch Office – Shanghai, China

Future Technology Devices International Limited (China)
Room 1103, No. 666 West Huaihai Road,
Shanghai, 200052
China
Tel: +86 21 62351596
Fax: +86 21 62351595

E-mail (Sales) cn.sales@ftdichip.com
E-mail (Support) cn.support@ftdichip.com
E-mail (General Enquiries) cn.admin@ftdichip.com

Web Site

<http://ftdichip.com>

Distributor and Sales Representatives

Please visit the Sales Network page of the [FTDI Web site](#) for the contact details of our distributor(s) and sales representative(s) in your country.

System and equipment manufacturers and designers are responsible to ensure that their systems, and any Future Technology Devices International Ltd (FTDI) devices incorporated in their systems, meet all applicable safety, regulatory and system-level performance requirements. All application-related information in this document (including application descriptions, suggested FTDI devices and other materials) is provided for reference only. While FTDI has taken care to assure it is accurate, this information is subject to customer confirmation, and FTDI disclaims all liability for system designs and for any applications assistance provided by FTDI. Use of FTDI devices in life support and/or safety applications is entirely at the user's risk, and the user agrees to defend, indemnify and hold harmless FTDI from any and all damages, claims, suits or expense resulting from such use. This document is subject to change without notice. No freedom to use patents or other intellectual property rights is implied by the publication of this document. Neither the whole nor any part of the information contained in, or the product described in this document, may be adapted or reproduced in any material or electronic form without the prior written consent of the copyright holder. Future Technology Devices International Ltd, Unit 1, 2 Seaward Place, Centurion Business Park, Glasgow G41 1HH, United Kingdom. Scotland Registered Company Number: SC136640

Appendix A – References

Document References

For module documentations, please refer to URL below :

FT90X series datasheet: [FT90X Series Datasheet](#)

FT900 tool chain installation guide : [FT900 Tool Chain Installation Guide](#)

FT900 Bootloader DFU usage guide: [FT900 Bootloader DFU Usage Application Note](#)

Acronyms and Abbreviations

Terms	Description
DC	Direct Current
DFU	Device Firmware Update
EVE	Embedded Video Engine
FCC/CE	North American EMI Verification/European Union EMC & Safety Compliance Declaration
FFC/FPC	Flexible Flat Cable/Flexible Printed Circuit
GPU	Graphics Processing Unit
HVGA	Half Size Video Graphics Array
IO	Input/output
LCD	Liquid Crystal Display
LED	Light-emitting diode
MCU	Microcontroller Unit
QFN	Quad-flat no-leads
SD	Secure Digital
SPI	Serial Peripheral Interface
SDHC	Secure Digital High Capacity
USB	Universal Serial Bus
VQFN	Very Thin Quad Flat Non-Leaded Package

Appendix B - List of Figures and Tables

List of Figures

Figure 1 - <i>CleO35</i> Bottom View	5
Figure 2 - Power Supply	6
Figure 3 - Micro-Controller.....	6
Figure 4 - MicroSD Interface.....	7
Figure 5 - LCD Interface	9
Figure 6 - Camera Interface	11
Figure 7 - Speaker Amplifier Circuitry	12
Figure 8 - 3.5 inch TFT Optical Specifications.....	17
Figure 9 - Sheet1 - FT810Q Connection	18
Figure 10 - Sheet2 - FT903Q Connection	19
Figure 11 - Sheet3 - Power and Connectors	20
Figure 12 - <i>CleO35</i> Block Diagram.....	21
Figure 13 - <i>Cleo35</i> Module Dimensions	22
Figure 14 - <i>CleO35</i> Bezel Drawing	23

List of Tables

Table 1 - LCD Connector Pin Out	9
Table 2 - Camera Connector Pin Out.....	10
Table 3 - Pin List of CN3.....	11
Table 4 - CN10 Jumper Selection.....	12
Table 5 - CN11 Jumper Selection.....	12
Table 6 - CN9 Pin List.....	13
Table 7 - CN8 Pin List.....	13
Table 8 - CN5 Pin List.....	14
Table 9 - CN12 Jumper Selection.....	14
Table 10 - CN6 Pin List.....	14
Table 11 - Temperature Parameter	15
Table 12 - Operating Voltage and Current.....	15
Table 13 - Display Specifications	16

Appendix C – Revision History

Document Title: CleO35 Module Datasheet
Document Reference No.: FT_001299
Clearance No.: FTDI# 493
Product Page: <http://www.ftdichip.com/Products/Modules/CleO.htm>
Document Feedback: [Send Feedback](#)

Revision	Changes	Date
Version 1.0	Initial Release	2016-04-20