

SPECIFICATION

- Part No. : **WMA.01. 301151**
- Product Name : **Trinity 3dBi 2.4~2.5GHz MIMO Antenna**
Wi-fi/ISM Bands/ZigBee/WLAN/Bluetooth
- Features : Connectors x 3 RP-SMA (M) –
3M RG-174
Omni-directional
Flexible Mounting
 - Desktop
 - Wall mount
 - Magnet Mount
 - Adhesive MountIEEE.802.11/IEEE.802.15
IP65 Water Resistant
RoHS Compliant



1. Introduction

The Trinity MIMO antenna is a powerful 3*3 3dBi External 2.4GHz omni-directional antenna to enable high-speed data throughput. 3 individual high-gain elements ensure maximum coverage through diversity. Desk-top placement, magnet-mounting, wall-mounting, adhesive mounting are all options. The individual antennas can articulate horizontally and vertically for best signal reception depending on mounting conditions.

Many module manufacturers specify peak gain limits for any antennas that are to be connected to that module. Those peak gain limits are based on free-space conditions. In practice, the peak gain of an antenna tested in free-space can degrade by at least 1 or 2dBi when put inside a device. So ideally you should go for a slightly higher peak gain antenna than mentioned on the module specification to compensate for this effect, giving you better performance.

Upon testing of any of our antennas with your device and a selection of appropriate layout, integration technique, or cable, Taoglas can make sure any of our antennas' peak gain will be below the peak gain limits. Taoglas can then issue a specification and/or report for the selected antenna in your device that will clearly show it complying with the peak gain limits, so you can be assured you are meeting regulatory requirements for that module.

For example, a module manufacturer may state that the antenna must have less than 2dBi peak gain, but you don't need to select an embedded antenna that has a peak gain of less than 2dBi in free-space. This will give you a less optimized solution. It is better to go for a slightly higher free-space peak gain of 3dBi or more if available. Once that antenna gets integrated into your device, performance will degrade below this 2dBi peak gain due to the effects of GND plane, surrounding components, and device housing. If you want to be absolutely sure, contact Taoglas and we will test. Choosing a Taoglas antenna with a higher peak gain than what is specified by the module manufacturer and enlisting our help will ensure you are getting the best performance possible without exceeding the peak gain limits.

The cables are shipped bonded together for easy cable management. The standard connector option of RP-SMA plugs into AP router equipment. Other cable and connector options are available on request.

DESKTOP / MAGNET MOUNT



Standard Desktop and Magnet Mount Configuration



Dipole Elements can be positioned



Magnets on Base

WALL MOUNT



Standard Configuration



Alternative Configuration



Screw-Holes on Base for Easy Wall-Mounting
(3M Adhesive can be supplied as option)

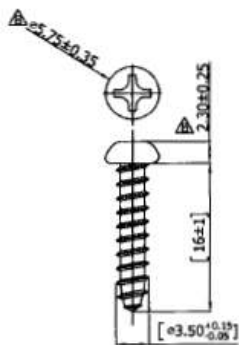

1. Screw - Cross Pan Head
For Plastic Tapping Thread
($\phi 3.5 \times 16L$)

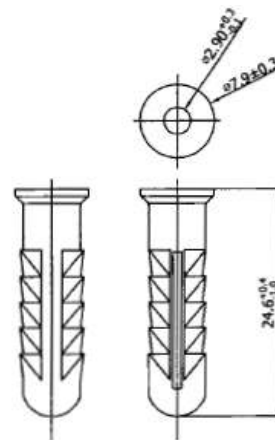

2. Wall Plug - Plastic

2. Electrical Specifications

Parameter	Specification
Frequency Range	2.4~2.5GHz
Impedance	50Ω
VSWR	1.92:1 Max.
Return Loss	-10dB Max
Radiation Pattern	Omni
Gain(Peak)	3dBi (excluding cable loss)
Cable Loss	5.7dB Max.
Polarization	Linear; Vertical
Power Handling	10W
Cable	RG-174 Coaxial cable
Connector	3 x RP-SMA(M)

2.1 Mechanical Specifications

Parameter	Specification
Base Dimensions	93mm Width * 105mm Length * 31mm Height
Antenna Elements	132mm Length
Antenna Body	TPE
Antenna Base	PC
Antenna Base	PBT
Operating Temperature	-40°C to +85°C
Storage Temperature	-40°C to +85°C
Color	Black

3. Technical Drawing

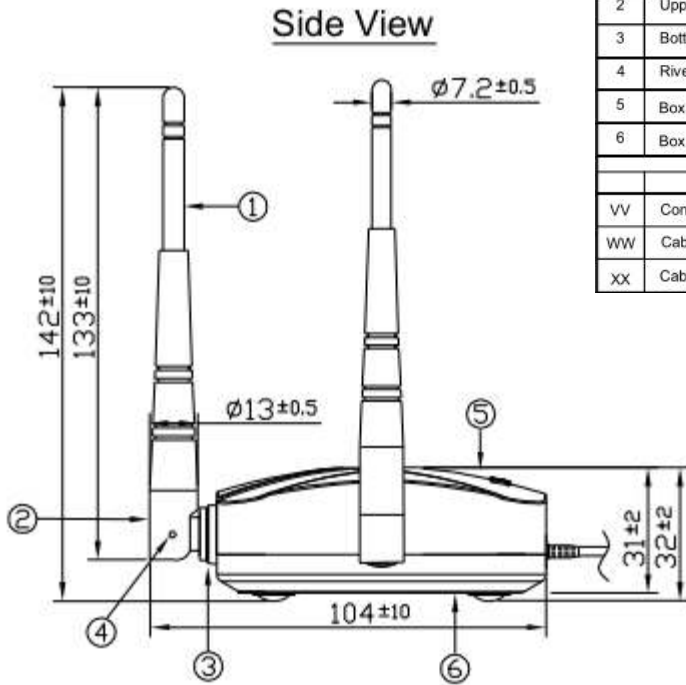

	Name	P/N	Material	Finish	QTY
1	Antenna Cap	000112C110015A	TPE	Black	3
2	Upper Fixed Base	000112C120015A	PC	Black	3
3	Bottom Fixed Base	000112C130015A	PBT	Black	3
4	Rivet	000112C140015A	POM	Black	3
5	Box Top	000112C150015A	ABS	Black	1
6	Box Bottom	000112C160015A	ABS	Black	1

	Name	P/N	Spec	Finish	QTY
VV	Connector Type	200211F0300XXA	SMA(M)RP Straight	Gold	3
WW	Cable Type	301311F0000XXA	RG174	Black	3
XX	Cable Length		3000±30mm		

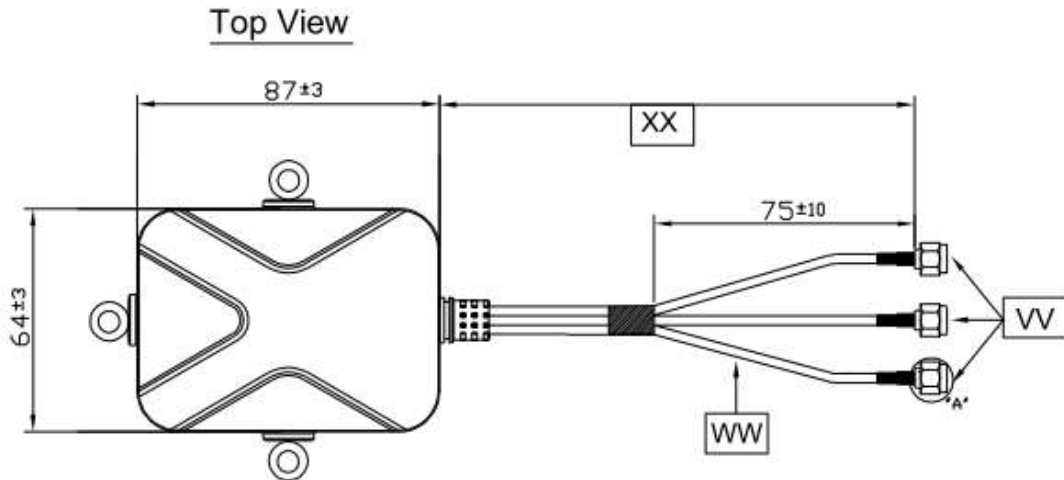

3.1 Connector Drawing

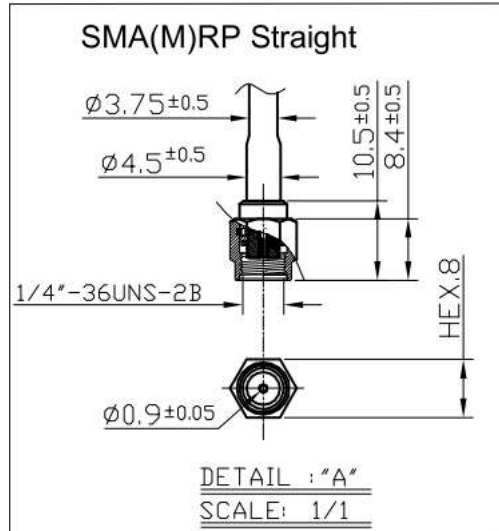

4. Performance

L-M

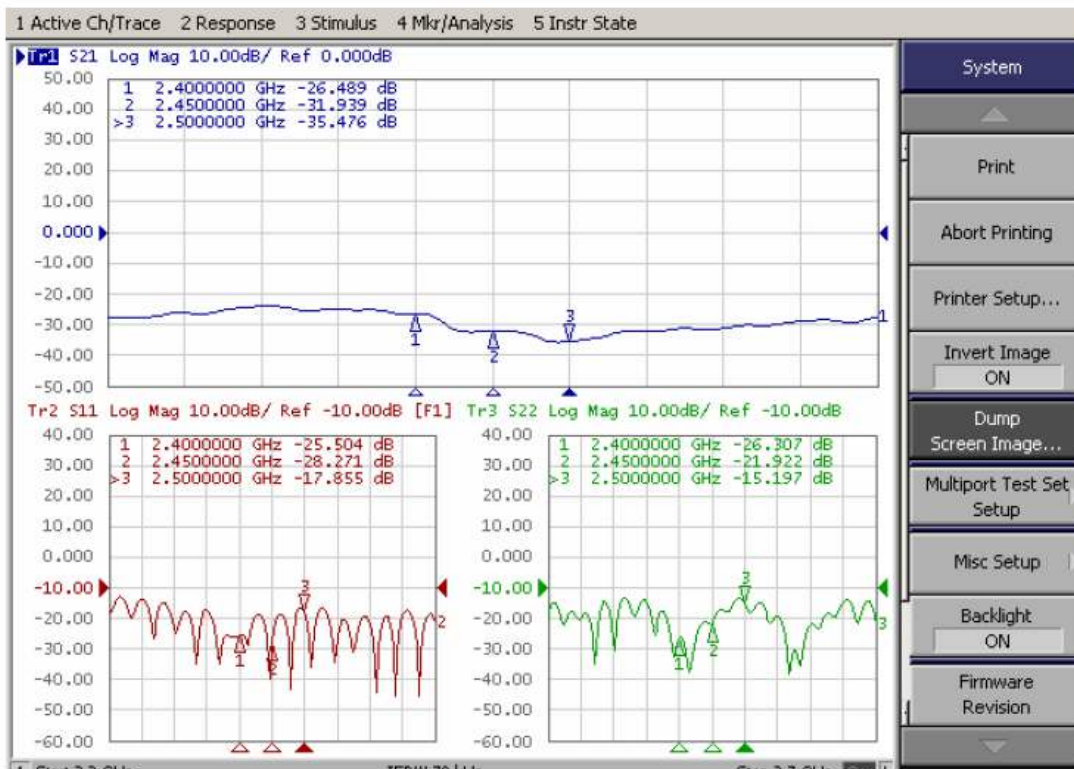

Return Loss and Isolation of Left and Middle Antenna

R-M

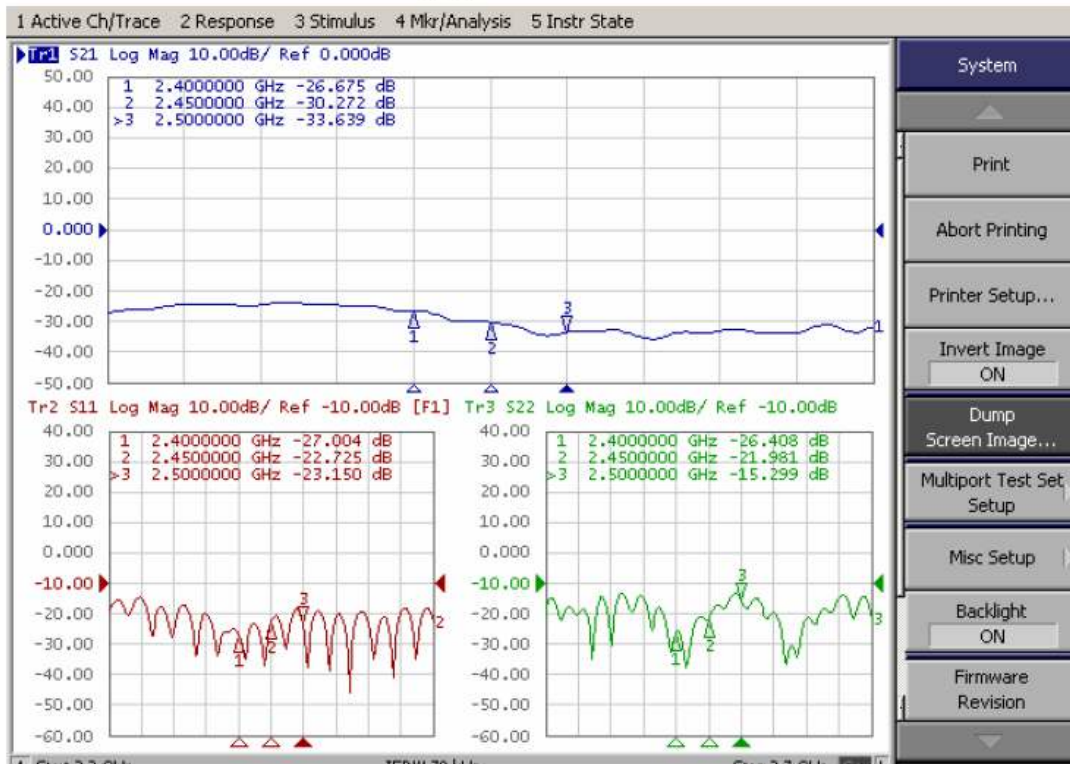

Return Loss and Isolation of Right and Middle Antenna

L-R

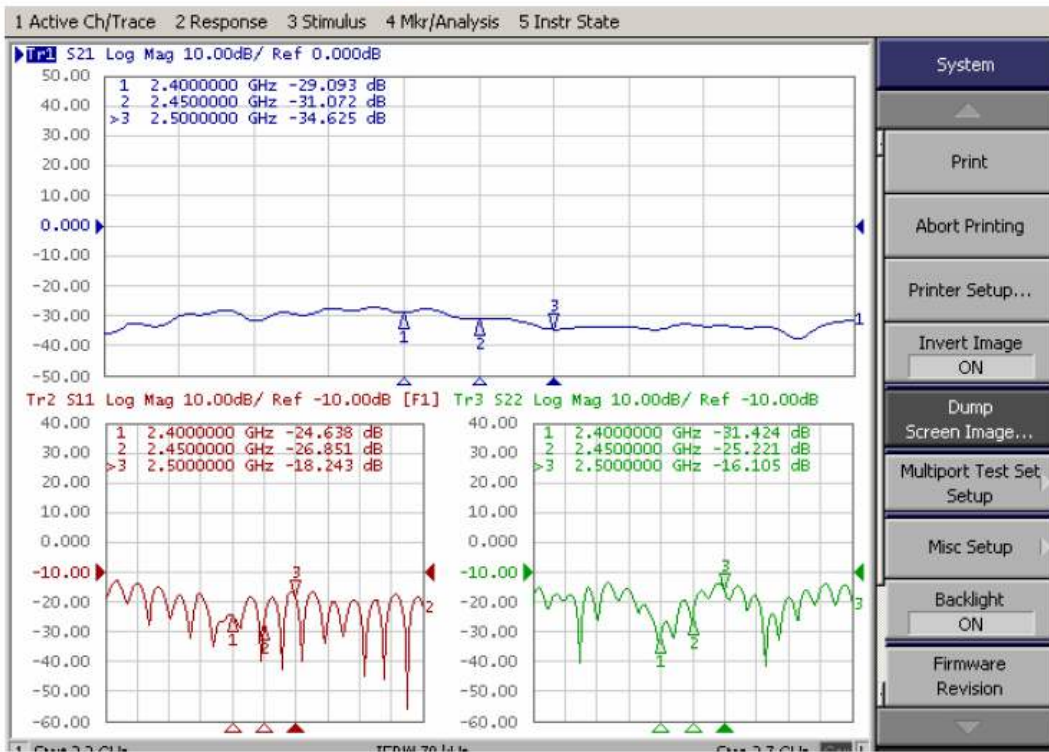

Return Loss and Isolation of Left and Right Antenna

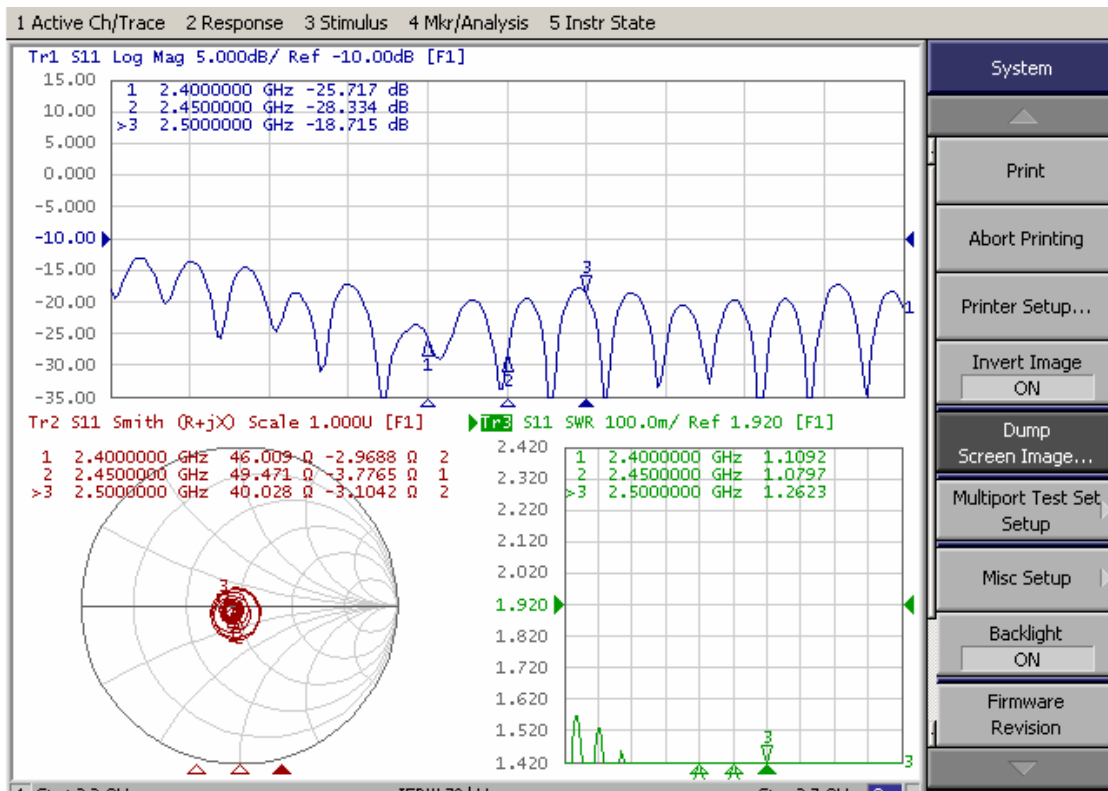

Return Loss, Smith Chart and VSWR of Left Antenna

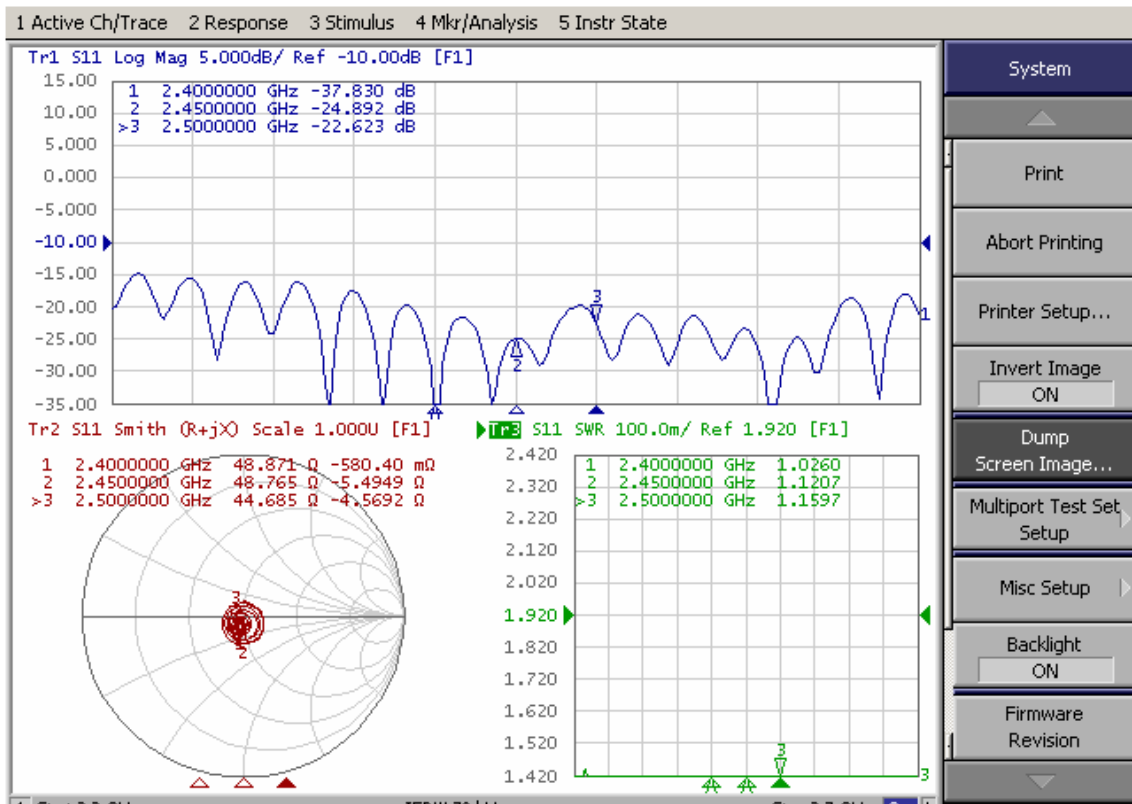

Return Loss, Smith Chart and VSWR of Middle Antenna

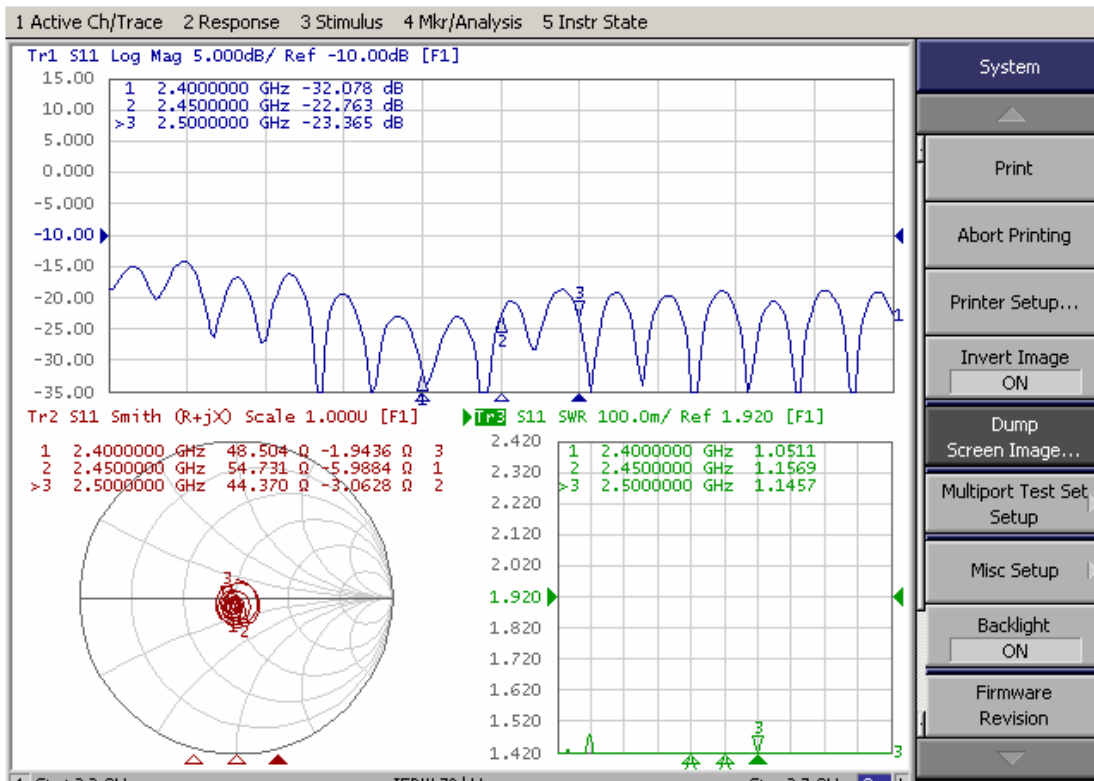

Return Loss, Smith Chart and VSWR of Right Antenna

Far-field amplitude of C1049-540039-A SSR-92863 L V H-PLANE.nsi

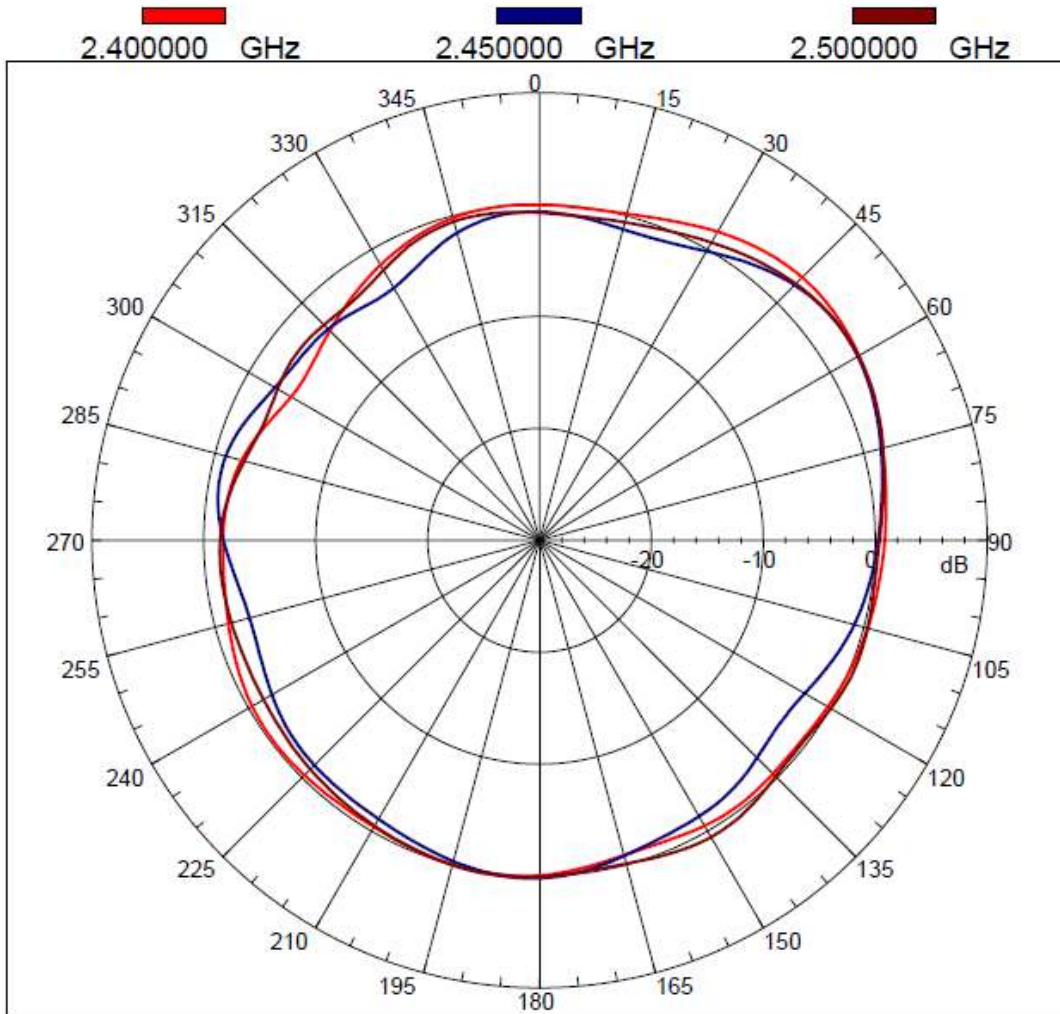

H-Plane Radiation Pattern of Left Antenna

Far-field amplitude of C1049-540039-A SSR-92763 M V H-PLANE.nsi

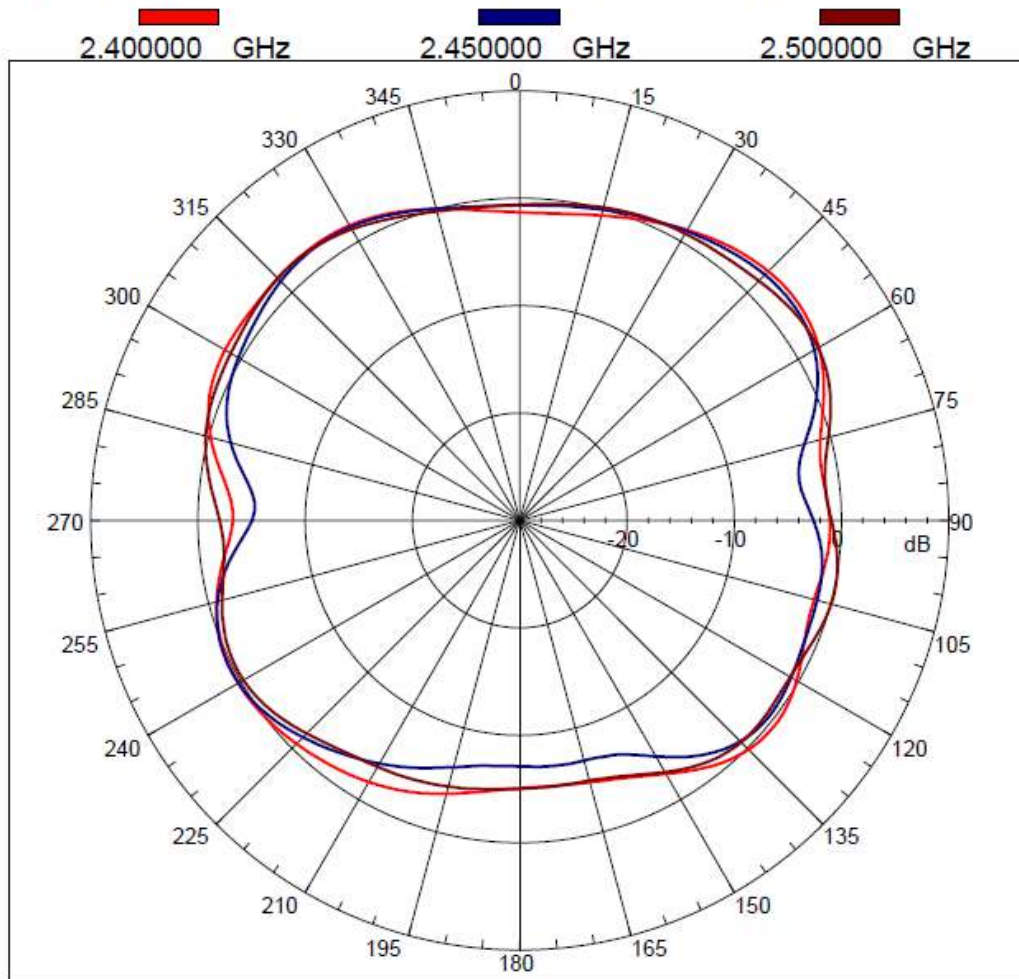

H-Plane Radiation Pattern of Middle Antenna

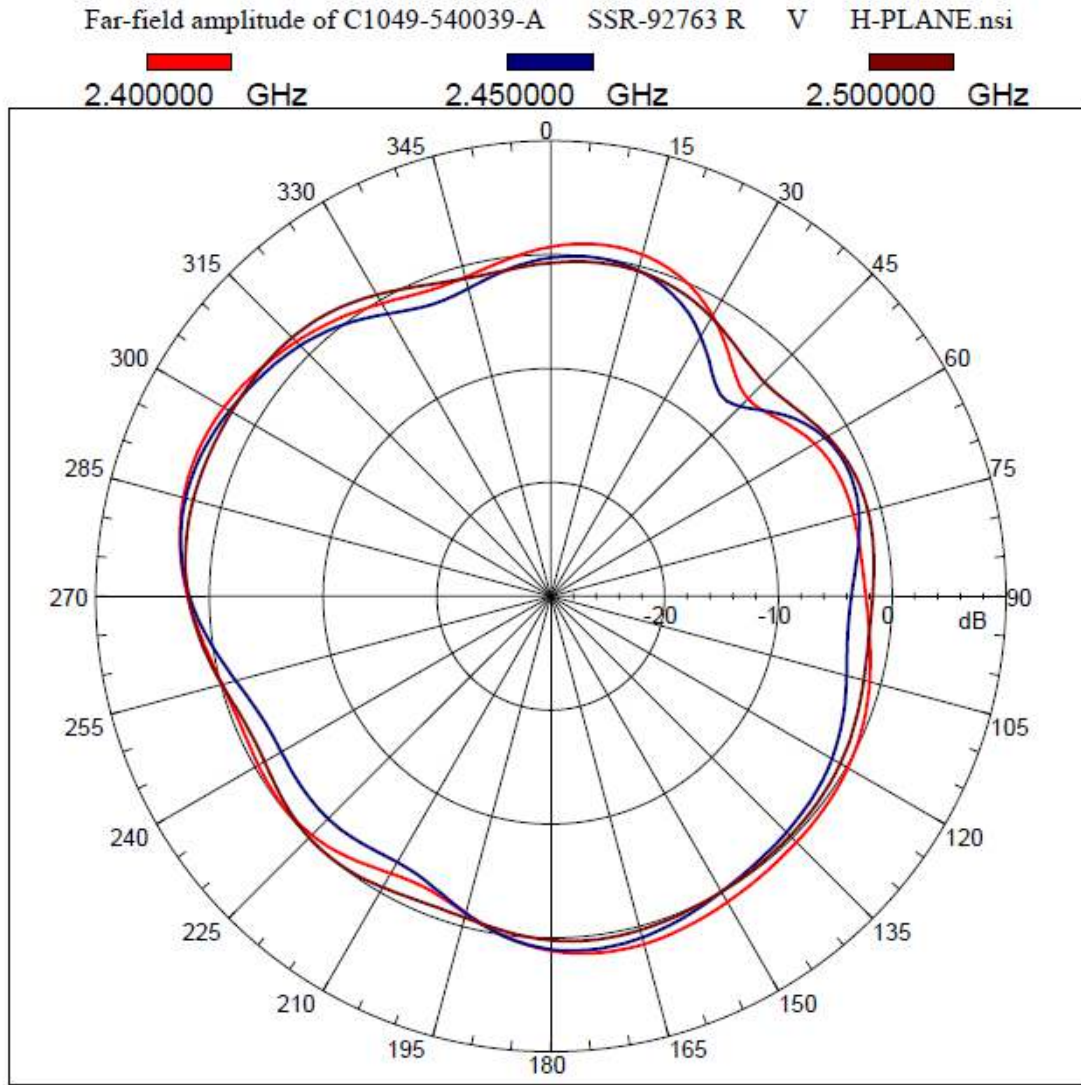

H-Plane Radiation Pattern of Right Antenna