

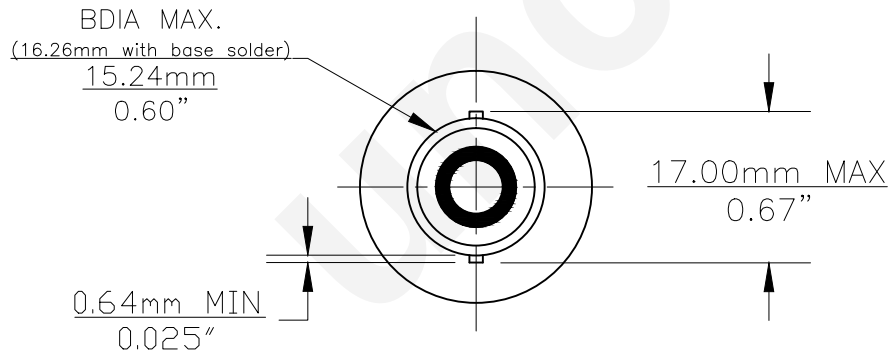

PART NO.	BASE TYPE	DESIGN VOLTS	DESIGN AMPS	MSCD	FILAMENT TYPE	AVERAGE LIFE HOURS	REVISIONS			
							REV #	DESCRIPTION	DATE	APPROVED
1156LL	S.C. Bayonet (BA15s)	12.8V	2.10±5%	32±10%	C-6	2400	1	ADDRESS CHANGE	01/20/2006	D.C.
							2	CHANGED RoHS COMPLIANCE	05/21/2007	S.L.
							3	ADDITIONAL BASE DIMENSION	10/03/2007	D.C.

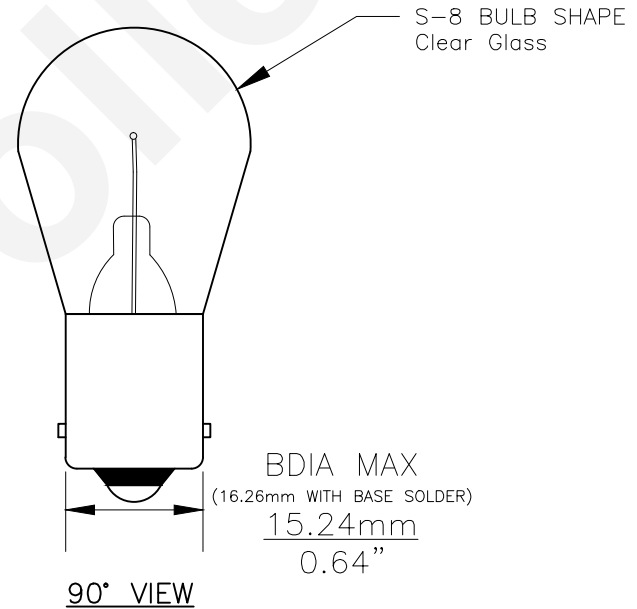

Note: Made according to SAE specifications

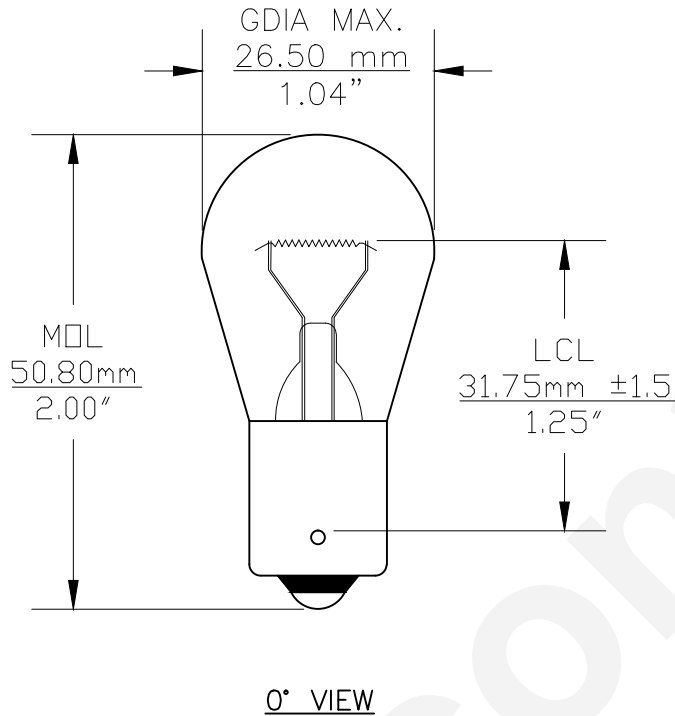

UNLESS OTHERWISE SPECIFIED: DIMENSIONS ARE IN INCHES TOLERANCES		CEC INDUSTRIES LTD			
DECIMALS	ANGULAR	599 BOND STREET		LINCOLNSHIRE, IL 60069	
.XX ± .05	± 0.5°	TITLE LIGHT BULB NO. 1156LL			
.XXX ± .010		SIZE A	FSCM NO.	DWG NO. 1156LL	REV 3
FRACTIONAL	±1/64	SCALE	PLOT SCALE	SHEET 1 OF 1	
DRAWN D.C. DATE 05/30/2013		MATERIAL FILE 1156LL.pdf DRAWING NOT TO SCALE			