

BCM5316X

2.5GbE Multiport Switch Series with High-Speed 10GbE Uplinks



Key Features

- Four 1GbE/2.5GbE SGMII+ ports.
- Two 2.5GbE/10GbE XFI/SFI ports.
- Up to eight 10/100/1000BASE-T ports with integrated GPHYs.
- An integrated ARM Cortex-M7 CPU.
- An RGMII, MII, and RvMII port to connect to an external CPU (or to be used as a 1GbE customer port).
- Cascading that enables creation of unified, single-CPU managed, 15- to 28-port switch.
- Support for advanced QoS, CFP, VLAN manipulation, up to L4 classification via CFP, and Time Sensitive Networking (TSN).
- Support for the IEEE 802.1BR port extender.
- Power-saving green technology per IEEE 802.3az Energy Efficient Ethernet.
- Support for both commercial (0°C to 70°C) and industrial (-40°C to +85°C) ambient temperature.

Applications

- Industrial Ethernet
- Unmanaged/web-managed/managed SMB switches
- Home gateway MDU
- Port extender

Description

The Broadcom® BCM5316X family of 2.5GbE switches is designed for high-end and cost-effective multi-Gigabit-Ethernet (multi-GbE) applications in the SMB, Industrial, and service provider markets. The switch family supports four 2.5GbE SGMII+ ports, two 2.5GbE/10GbE XFI/SFI ports, and eight 10/100/1000BASE-T ports with integrated GPHYs.

The BCM5316X switch family is based on the industry-leading 28 nm RoboSwitch™ architecture, also known as Robo-2. This switch family integrates the powerful ARM Cortex-M7 CPU that enables customers to design switching platforms without adding an external processor. These products are also equipped with the high-end forwarding mechanisms required in many advanced applications. These mechanisms include an advanced QoS engine, flexible content filter processor (CFP), sophisticated VLAN manipulation capability, security features, packet synchronization for time-sensitive networks, and many more.

The BCM5316X family of switches is supported by multiple software packages designed for various applications. Basic, unmanaged software can be used to construct unmanaged switches with basic functionalities and no VLAN segregation. Web-managed software (such as ROBO-OS™) can be used to build web-controlled switches while full-featured SDK software can be used to construct managed devices that are controlled by an external CPU. For example, home gateways and Ethernet MDU switches can connect the BCM5316X switches to an external PON or DSL SoC.

The BCM5316X family of switches can be used to construct standalone platforms with low port-count configuration (up to 15 ports), or a cascaded design with double port-count switches by connecting two devices back-to-back.

The BCM5316X switches are offered to customers in commercial-grade ambient temperature.

Benefits

- Support for cascading mode that enables the creation of a unified, single-CPU managed, 16- to 26-port switch.
- Support for high-end QoS capabilities with hierarchical scheduling, eight egress buffer queues per port each with its own shaper, WRED and Tail-drop congestion avoidance, and dual *leaky bucket* ingress rate limiters (also known as policers).
- Advanced CFP (such as an access-list engine) that can classify up to L4 headers.
- Support for virtual switching instances (VSI) for explicit segregation of bridging domains with advanced VLAN translation and encapsulation (for example, MAC-in-MAC).

Benefits (con't)

- Port-extender support, per IEEE 802.1BR, for designing modular chassis devices or *pizza box* platforms with remote port extensions.
- Advanced TSN protocol support, such as IEEE 802.1Qav, 802.1Qbv, 802.1ASrev, and 802.1Qci, for scheduling time-critical traffic streams across an entire network domain.
- Delivered with unmanaged software, web-managed software, or two different managed SDK software (RoboSwitch SDK and Network Switch SDK).

BCM5316X Block Diagram

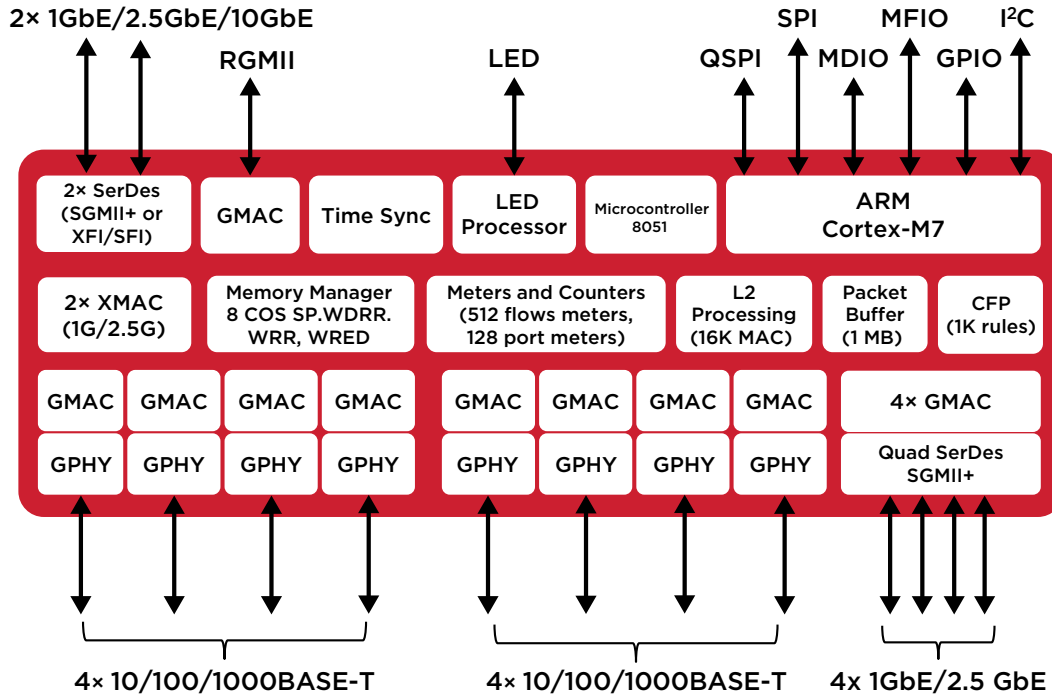

Ordering Information

Description	Ambient Temperature	Package	Device ID
Intelligent, unmanaged 2.5GbE Robo-2 switch with 4x 1000FX/2500FX SGMII+ ports + 2x 1000FX/2500FX/10000FX XFI/SFI ports	Commercial (0°C to +70°C)	19 mm x 19 mm	BCM53161XUB0KLFBG
Intelligent, managed 2.5GbE Robo-2 switch with 4x 1000FX/2500FX SGMII+ ports + 2x 1000FX/2500FX/10000FX XFI/SFI ports	Commercial (0°C to +70°C)	19 mm x 19 mm	BCM53161XMB0KLFBG
Intelligent, managed 2.5GbE Robo-2 switch with 8x 10/100/1000BASE-T + 4x 1000FX/2500FX SGMII+ ports + 2x 1000FX/2500FX/10000FX XFI/SFI ports	Industrial (-40°C to +85°C)	19 mm x 19 mm	BCM53161XMB0ILFBG