

# Single-phase Power Controller G3PW

## High-precision Control with Easy Setup



- Precise heater burnout detection.
- Set value and present value monitoring with indicators.
- Phase control or optimum cycle control.
- RS-485 communications to set manipulated variables and monitor load current.
- Total run time monitoring.
- Output modes for phase control: proportional to phase angle, proportional to voltage, proportional to square voltage, and constant-current control.
- Application with various loads: constant load resistance, variable load resistance.
- UL, and IEC/EN (TÜV) certified.



**NEW**

For the most recent information on models that have been certified for safety standards, refer to your OMRON website.

## Model Number Structure

### Model Number Legend

**G3PW-A2**□□**E**□-□-□□□□

1    2 3 4 5 6 7    8

- |  |  |  |
|--|--|--|
| <p><b>1. Basic model</b><br/>G3PW: Power Controller</p> <p><b>2. Degree of protection</b><br/>A: Panel-mounting/Closed wallmounting</p> <p><b>3. Voltage class</b><br/>2: 100 to 240 VAC</p> | <p><b>4. Maximum rated current</b><br/>20: 20 A<br/>45: 45 A<br/>60: 60 A</p> <p><b>5. Power supply type</b><br/>E: Single-phase power supply</p> <p><b>6. Current control</b><br/>U: Standard Model (no constant-current control)<br/>C: Constant-current Model</p> | <p><b>7. Control terminal block</b><br/>C: Screwless clamp terminal block<br/>S: Terminal block with small slotted screws</p> <p><b>8. RS-485 communications</b><br/>Blank: Communications not supported.<br/>FLK: Communications supported.</p> |
|--|--|--|

## Ordering Information

### List of Models

Number of phases	Control terminal block	Type	Capacity	Heater burn-out detection	Communications	Model number		
Single-phase	Screwless clamp terminal block	Standard	20 A	No	No	G3PW-A220EU-C		
			45 A			G3PW-A245EU-C		
			60 A			G3PW-A260EU-C		
		Constant current	20 A			Yes	Yes	G3PW-A220EC-C-FLK
			45 A					G3PW-A245EC-C-FLK
			60 A					G3PW-A260EC-C-FLK
	Terminal block with small slotted screws	Standard	20 A	No	No			G3PW-A220EU-S
			45 A					G3PW-A245EU-S
			60 A					G3PW-A260EU-S
		Constant current	20 A			Yes	Yes	G3PW-A220EC-S-FLK
			45 A					G3PW-A245EC-S-FLK
			60 A					G3PW-A260EC-S-FLK

### Accessories (Order Separately)

Name	Resistive value	Display	Model
External Variable Resistor	2 kΩ	202	G32X-V2K

## Ratings/Specifications

Item		Model	Standard Models	Constant-current Models
			G3PW-A2□□EU-□	G3PW-A2□□EC-□-FLK
Control method		Analog input: Phase control or optimum cycle control Voltage ON/OFF input: ON/OFF control		
Maximum load capacity		<ul style="list-style-type: none"> <li>Phase control: Linear (resistive) load, transformer primary-side control (flux density: 1.25 T max.)</li> <li>Optimum cycle control: Linear (resistive) load (Transformer primary-side control is not supported.)</li> </ul>		
Output mode	Analog input	Phase control	Proportional to phase angle, proportional to square voltage, proportional to voltage	Proportional to phase angle, proportional to square voltage, proportional to voltage, constant-current control
		Optimum cycle control	Optimum cycle control (Output is switched to 100% or 0% each half cycle.)	
	Voltage ON/OFF input	ON/OFF control	Proportional to voltage control	
Phase		Single		
Rated voltage		100 to 240 VAC		
Operating voltage range		-15% to +10%		
Power supply frequency		50/60 Hz		
Power supply frequency fluctuation		±3 Hz		
Power consumption		5 VA max. (Control power ④-⑤)		
Load current range	-A220E□	1 to 20 A		
	-A245E□	1 to 45 A		
	-A260E□	1 to 60 A		
Inrush current resistance	-A220E□	220 A (60 Hz, 1 cycle)		
	-A245E□	440 A (60 Hz, 1 cycle)		
	-A260E□	440 A (60 Hz, 1 cycle)		
I <sup>2</sup> t	-A220E□	400A <sup>2</sup> s (1 cycle)		
	-A245E□	1,600A <sup>2</sup> s (1 cycle)		
	-A260E□	1,600A <sup>2</sup> s (1 cycle)		
Output voltage adjustable range		0% to 98%		
Input signal for control	Analog input	4 to 20 mA DC (input impedance: 100 Ω) or 1 to 5 VDC (input impedance: 30.1 kΩ)		
	Voltage ON/OFF Input	5 VDC (input impedance: 30.1 kΩ)		
	External main setting	Specified Variable Resistor: G32X-V2K (2 kΩ, 2 W)		
	External duty setting	Specified Variable Resistor: G32X-V2K (2 kΩ, 2 W)		
Output value setting range	Main setting	0.0% to 100%		
	Base-up value	0.0% to 100% (Default: 0.0%)		
	Upper/lower limits	Output upper limit: 0.0% to 100% (Default: 100%) Output lower limit: 0.0% to 100% (Default: 0.0%)		
	Duty setting	Duty setting = Internal duty setting x External duty setting Internal duty setting range (set using front-panel keys or communications): 0% to 100% (Default: 100%) External duty setting range (set using external variable resistor): 0% to 100% (Default: 100%)		
Soft-start up time and soft-start down time		0.0 to 99.9 s (Default: 0.5 s) Either phase control or optimum cycle control can be used.		
Constant current		---		
Load current upper limit		---		
Current detection	Current transformer (CT)	---		
	Current detection accuracy	---		
	Minimum detected load current	---		
Heater burnout alarm	Detection method	---		
	Setting range for heater burnout detection	---		
	Burnout detection accuracy	---		
	Burnout detection output lower limit	---		
	Number of alarms for heater burnout detection	---		
Event inputs	Multiple heater burnout detections	---		
	Number of event inputs	2 event inputs Event input 1: The function of the event input can be changed with a parameter setting in the initial setting level. The event input can be used for one of the following functions. <ul style="list-style-type: none"> <li>Switching the main setting between automatic and manual operation.</li> <li>Switching between phase control and optimum cycle control.</li> </ul> Event input 2: Alarm reset		
	Contact input conditions	ON: 1 kΩ max., OFF: 100 kΩ min.		
	Non-contact input conditions	ON residual voltage: 1.0 V max., OFF leakage current: 0.1 mA max.		
	Current flow	Approx. 1.1 mA (per input)		
	Output voltage	5 VDC		

Item		Model	Standard Models	Constant-current Models
			G3PW-A2□□EU-□	G3PW-A2□□EC-□-FLK
Alarm outputs	Number of alarm outputs	2 alarm outputs <ul style="list-style-type: none"> <li>Alarm output 1: ALARM1 (caution)</li> <li>Alarm output 2: ALARM2 (warning)</li> </ul> Open-collector outputs (Individual common)		
	Maximum operating voltage	30 VDC		
	Maximum load current	50 mA		
	Maximum residual voltage	1.5 V		
	Maximum leakage current	0.4 mA		
Serial communications			---	One RS-485 port: CompoWay/F slave function (See note.) <b>Note:</b> Connection is possible to a Basic Unit in an EJ1 Modular Temperature Controller. Parameters can be set and monitored from the CX-Thermo Support Software running on a computer that is connected to the EJ1 End Unit.
Overcurrent detection			---	Rated current × 120% min., within 250 cycles
SSR failure detection		An error is detected within 3 seconds after an SSR failure. <ul style="list-style-type: none"> <li>Phase angle range for SSR short-circuit failure detection: 0% to 72%</li> <li>Phase angle range for SSR open failure detection: 28% to 100%</li> </ul>		
Output ON voltage drop		1.6 Vrms (at 100 % output on)		
Power supply frequency error		Not within 47 to 63 Hz		
Leakage current		10 mA max. (100/110 VAC), 20 mA max. (200/220 VAC)		
Insulation resistance		100 MΩ min. (at 500 VDC)		
Dielectric strength		2,500 VAC at 50/60 Hz for 1 min between charged parts and noncharged parts		
Vibration resistance		10 to 55 to 10 Hz, 100 m/s <sup>2</sup>		
Shock resistance		300 m/s <sup>2</sup>		
Ambient operating temperature		-15°C to 55°C (with no icing or condensation)		
Ambient operating humidity		5% to 95%		
Storage temperature		-25°C to 65°C (with no icing or condensation)		
Weight		G3PW-A220E□-□-□□□: 1.0 kg max. G3PW-A245E□-□-□□□: 1.9 kg max. G3PW-A260E□-□-□□□: 1.9 kg max.		
Applicable Standards	Safety Standards	cULus (File No.E64562) TÜV (File No.R50140135, EN60947-4-3)		
	EMC Directives	EMI EN60947-1 EN60947-4-3 EMS EN60947-1 EN60947-4-3		

#### Fuses (recommended models for external connection)

Recommended models Type	Super-rapid Fuse (Fuji Electric)		Fuse Holder (Fuji Electric)
	Fast-acting fuses	For 20 A	CR6L-20/UL
For 45 A		CR6L-50/UL	
For 60 A		CR6L-75/UL	CMS-5

#### Time-delay fuses specifications

Type	Specification
Time-delay fuses	250 VAC, 2 A

# Nomenclature and Operations

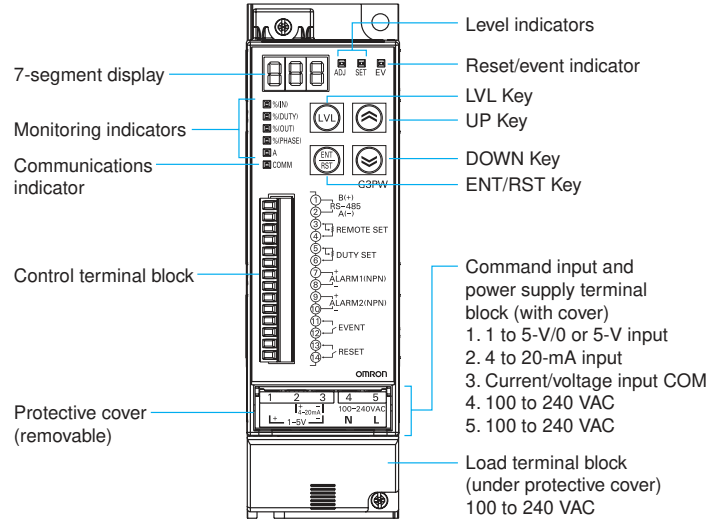

## Level Indicators

Indicator	Description
■ ADJ	Lit when in the adjustment level.
■ SET	Lit when in the initial setting level.
■ EV	Lit when an external contact reset input or an event input is ON.

## Monitoring Indicators

Indicator	Description
■ %(IN)	Lit when the input value is monitored in the monitor level.
■ %(DUTY)	Lit when the duty value is monitored in the monitor level.
■ %(OUT)	Lit when the output value is monitored in the monitor level.
■ %(PHASE)	Lit when the phase angle is monitored in the monitor level.
■ A	Lit when the current is monitored in the monitor level.

## Communications Indicator

Indicator	Description
■ COMM	Lit when the serial communications are in progress.

## Operation Keys

Key symbol	Name	Description	Enabling condition
	LVL (level) Key	Level Changes Monitor level ↔ Adjustment level Monitor level ↔ Initial setting level Software is reset when moving from the initial setting level to monitor level.	Changing from monitor level to adjustment level or from monitor level to initial setting level is possible even when an error occurs.
	ENT/RST (enter/reset) Key	Set value display Set value change and entry Error reset	In the monitor level, the ENT/RST Key functions as a Reset Key only when an error occurs. (It does not function as a Reset Key when there is no error.)
	UP Key	Set value change	---
	DOWN Key	Monitor item/set value number change	

# Engineering Data

## Ambient Temperature

### Current and Temperature Characteristics

#### G3PW-A220E□/A245E□

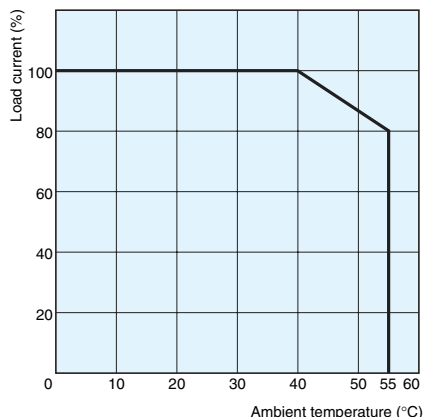

#### G3PW-A260E□

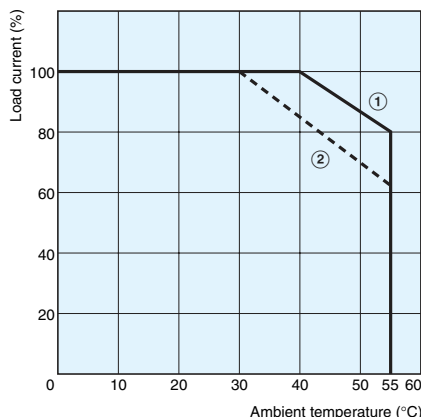

- ①: Installation with 20 mm between Power Controllers
- ②: Close mounting

- Note:**
- The ambient operating temperature range is  $-15$  to  $55^{\circ}\text{C}$ , but take the following considerations into account. When the ambient temperature exceeds  $40^{\circ}\text{C}$ , reduce the maximum load current as shown below.
  - At least 20 mm must be provided on the left and right sides of the G3PW-A260E□. If you must use side-by-side mounting, then reduce the maximum load current when the ambient temperature is over  $30^{\circ}\text{C}$ .
  - Certification for safety standards was obtained with a mounting interval of 20 mm.
  - Leave sufficient space for ventilation.
  - Do not install the Power Controller above devices that generate significant amounts of heat, such as heaters, transformers, and high-capacity resistors.
  - If the ambient temperature reaches  $55^{\circ}\text{C}$  or higher, install an air conditioner to lower the temperature.

### Resistance to Inrush Current (For repetitive inrush current, keep the inrush current below the values shown by the dotted lines.)

#### G3PW-A220E□

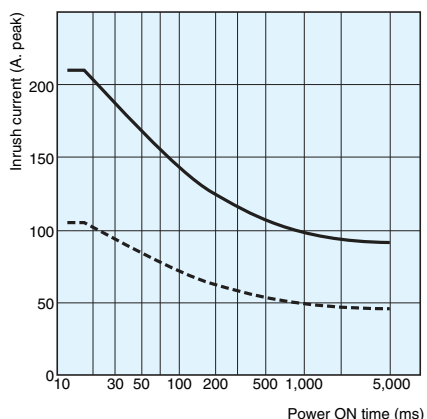

#### G3PW-A245E□/G3PW-A260E□

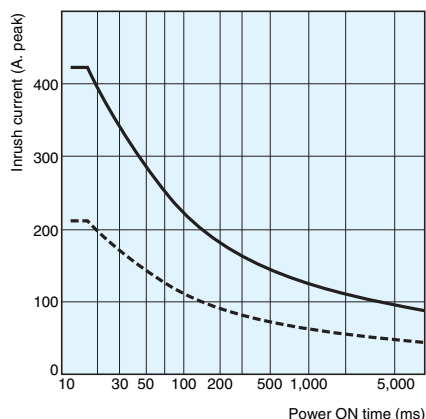

# G3PW

## Dimensions

Note: All units are in millimeters unless otherwise indicated.

### 20-A Models with Screwless Clamp Terminal Block

G3PW-A220EU-C  
G3PW-A220EC-C-FLK

#### Mounting Hole Dimensions

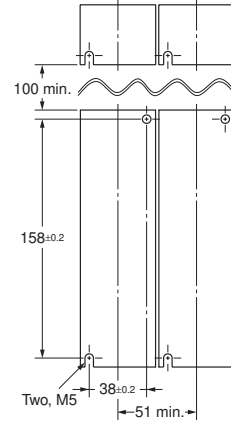
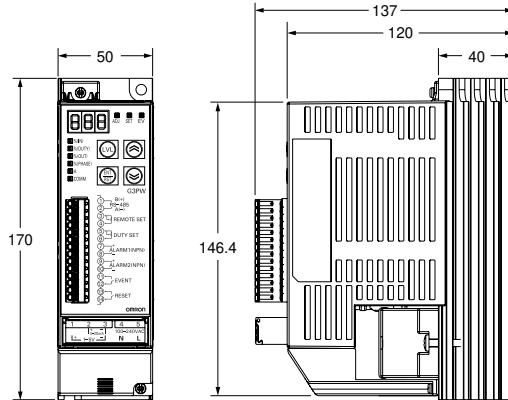

### 45/60-A Models with Screwless Clamp Terminal Block

G3PW-A245EU-C  
G3PW-A260EU-C  
G3PW-A245EC-C-FLK  
G3PW-A260EC-C-FLK

#### Mounting Hole Dimensions

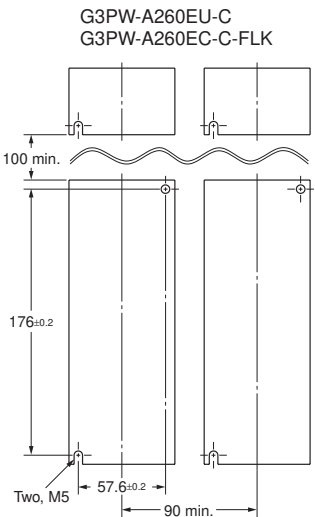
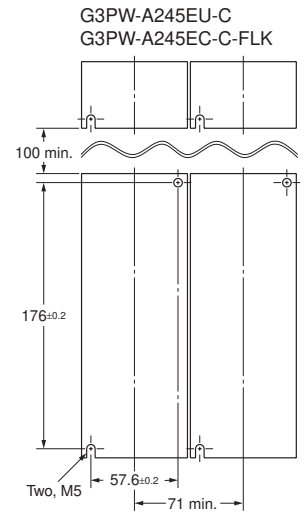
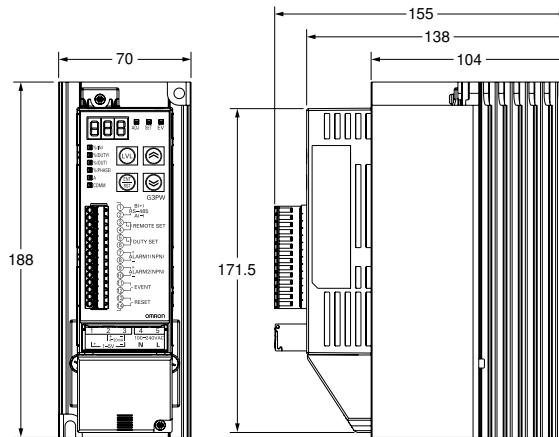

**20-A Models with Terminal Block with Small Slotted Screws**

G3PW-A220EU-S  
G3PW-A220EC-S-FLK

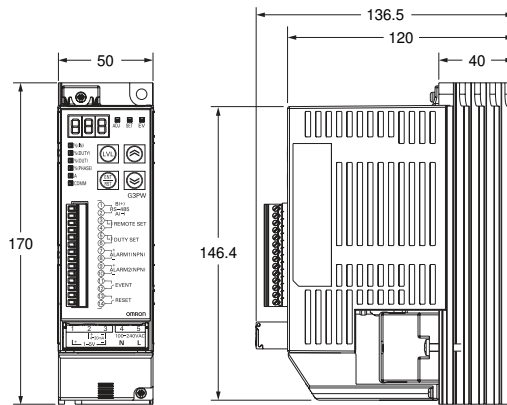

**Mounting Hole Dimensions**

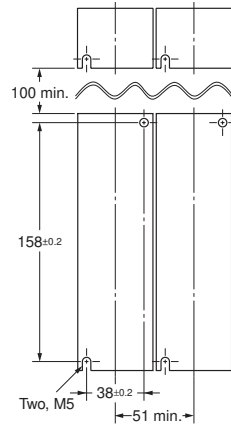

**45/60-A Models with Terminal Block with Small Slotted Screws**

G3PW-A245EU-S  
G3PW-A260EU-S  
G3PW-A245EC-S-FLK  
G3PW-A260EC-S-FLK

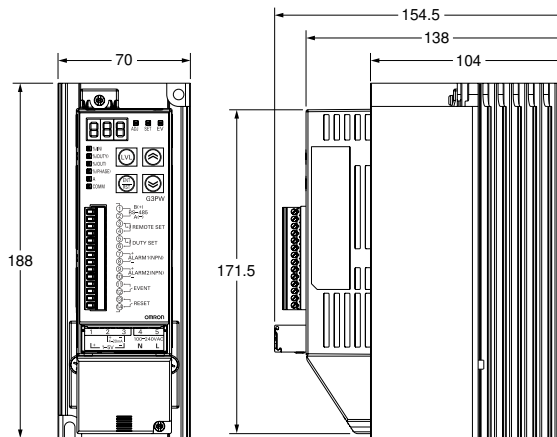

**Mounting Hole Dimensions**

G3PW-A245EU-S  
G3PW-A245EC-S-FLK

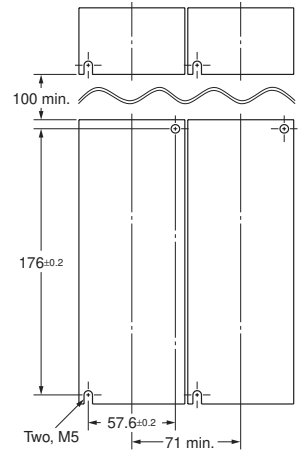

G3PW-A260-EU-S  
G3PW-A260-EC-S-FLK

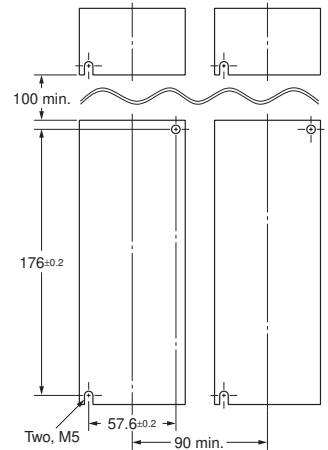

**Accessories (Order Separately)**

**External Variable Resistor**

G32X-V2K

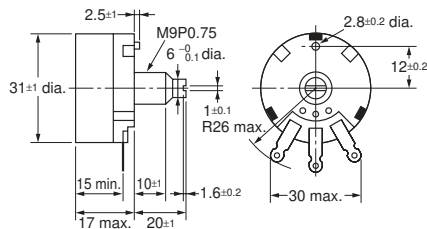

**Mounting Holes**

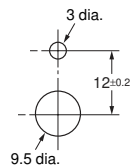

**Nameplate**

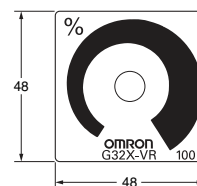

**Knob**

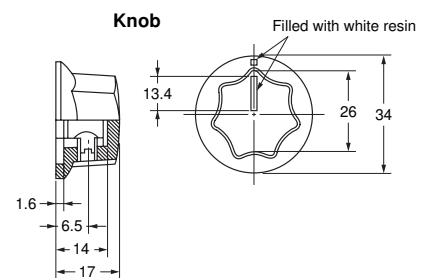

## Safety Precautions

### ⚠ WARNING

Do not attempt to disassemble the Power Controller while the power is being supplied. Doing so may occasionally result in strong electric shock.



Do not touch any of the terminals while the power is being supplied. Also, always attach the terminal block cover after completing wiring. Touching live terminals may occasionally result in serious injury due to electric shock.



Fail-safe measures must be taken by the customer to ensure safety in the event of incorrect, missing, or abnormal signals caused by broken signal lines, momentary power interruptions, or other causes. Abnormal operation may result in serious accidents.



Do not use the Power Controller where subject to flammable or explosive gas. Otherwise, explosion may occur.



Use the wire sizes given in this document and use twisted copper wires or solid copper wire. Use crimp terminals with insulative sleeves. If the crimp terminals do not come with insulative sleeves, attach insulative sleeves. Use the size of crimp terminals specified in this document.



Make sure that the phases match for load terminal T1 and power supply terminal 4 (N), and for load terminal L1 and power supply terminal 5 (L). Insert suitable fuses in the power supply line and load output line to protect the circuits.



The Power Controller will not operate normally if the wiring is not correct, and the load may be damaged.

Leave at least 100 mm of space above and below the Power Controller when installing it to allow heat to dissipate. Do not obstruct the area around the Power Controller and especially the area around the heat sink.



Install the Power Controller in the direction shown in this Instruction Sheet. The Power Controller generates a lot of heat and it uses natural heat convection for cooling. Installing the Power Controller in the wrong direction may cause in malfunctions or accidents.



Do not touch the terminal sections while a voltage is being applied after the power supply terminal block and load terminal block have been wired. The power supply terminal block and load terminal block are not isolated to enable an alarm function. Electric shock may occur.



### ⚠ CAUTION

The Power Controller and the heat sink become very hot. Do not touch anything but the setting keys while power is being supplied or just after the power supply is turned OFF. Doing so may cause burns.



Do not attempt to disassemble, modify, or repair the Power Controller or touch any of the internal parts. Minor electric shock, fire, or malfunction may occasionally occur.



Do not allow chips or filings from installation work, pieces of metal, or wire clippings to enter the Power Controller. Doing so may occasionally result in minor electric shock, fire, or malfunction.



Always connect the load to load terminal T1. Also, always connect power supply terminal 4 (N) directly to the power supply. Do not connect it through the load. If the wiring is not correct, the fault detection function of the Power Controller will indicate "E10" and stop the output operation. Check the connection again.



When using the Power Controller to control the primary side of a transformer, do not open the circuit on the secondary side of the transformer while the Power Controller is operating.



Do not touch the connecting cables while power is being supplied. Static electricity from your body may cause malfunctioning.



If a malfunction in the Power Controller prevents control operations or if an alarm cannot be output, it may occasionally cause damage to the connected equipment and devices. To maintain safety in the event of a malfunction in the Power Controller, always take appropriate safety measures, such as installing a separate monitoring system.



Set the parameters of the Power Controller so that they are suitable for the system being controlled. If they are not suitable, unexpected operation may occasionally result in property damage or accidents.



Tighten the terminal screws to the torque specified in this Instruction Sheet. If the screws are loose, it may occasionally cause a fire.





## Precautions for Safe Use

OMRON constantly strives to improve quality and reliability. The G3PW, however, uses semiconductors, and semiconductors may commonly malfunction or fail. In particular, it may not be possible to ensure safety if the G3PW is used outside the rated ranges. Therefore, always use the G3PW within the ratings. When using the G3PW, always design the system to ensure safety and prevent human accidents, fires, and social harm in the event of G3PW failure. System design must include measures such as system redundancy, measures to prevent fires from spreading, and designs to prevent malfunction.

1. Do not apply a voltage or current in excess of the ratings to the terminal sections of the G3PW. Doing so may result in failure of the G3PW or fire damage.
2. Do not use the G3PW with loose terminal screws. Abnormal terminal heat may result in fire damage.
3. Do not obstruct the airflow around the heat sink of the G3PW. Abnormal heat may result in failure due to shorting of the output terminals or fire damage.
4. Be sure to read the *Precautions for Correct Use* to correctly perform wiring and tighten screws. Using the G3PW with incorrect wiring or insufficient screw tightening may result in fire damage due to abnormal heat when the power is supplied.

### Installation Environment

- Use the Power Controller within the rated ambient temperature and humidity ranges.
- If multiple Power Controllers are installed side-by-side or vertically, the heat that is generated will cause the internal temperatures of the Power Controllers to rise and will shorten their service life. In these kinds of installations, take suitable measures, such as installing fans for forced cooling.
- The Power Controller is designed for indoor use only. Also, do not use the Power Controller in the following environments.
  - Locations subject to water, oil, or chemicals
  - Locations subject to direct sunlight
  - Locations where dust or corrosive gases (in particular, sulfuric or ammonia gas) are present
  - Locations subject to extreme temperature changes
  - Locations where icing or condensation may occur
  - Locations subject to excessive shocks or vibration
  - Locations subject to direct heat radiated from heating devices

### Installation and Wiring

- When installing the Power Controller, always securely tighten the top mounting screws first. When removing the Power Controller, always remove the bottom mounting screws first.
- Take safety measures, such as wearing safety shoes, in case the Power Controller falls.
- Touch the Power Controller only after first touching a grounded metal object to discharge any static electricity from your body.
- Always ground the Power Controller to 100  $\Omega$  or less. There are no ground terminals provided, so use the heat sink mounting screws as ground terminals.
- Check the terminal number and polarity for each input before connecting it.
- Use copper twisted wire in the sizes specified in this Instruction Sheet.
- Use insulated crimp terminals with insulation sleeves. If using crimp terminals that are not insulated, cover them with insulation sleeves. Also, use terminals of the sizes specified in this Instruction Sheet.
- Insert connectors all the way.
- Do not connect anything to unused terminals.

### Safety Measures and Checking

- Install a switch or circuit breaker so that the operator can immediately turn OFF the power, and provide a suitable display.
- Apply the power supply voltage through the contacts of a switch, relay, or similar device so it reaches the rated voltage within 2 s. If the power supply voltage is increased gradually, the power supply may not be reset or outputs may malfunction.
- Use a power supply voltage, input voltage, input current, and load within the specifications and rated ranges for the Power Controller.
- Use a load that draws a current at the maximum output that is within the rated current range of the Power Controller. If the current drawn by the load is not within the rated current range, malfunction or fire may occur.
- Make sure that the protective cover is attached to the load terminal block before using the Power Controller. Failure to do so may damage internal components due to mechanical stress.

### Preventing Inductive Noise

- Allow as much space as possible between the Power Controller and devices that generate powerful high frequencies (high-frequency welders, high-frequency sewing machines, etc.) or surge.
- Keep the signal lines that connect to the Power Controller's terminal block away from power cables carrying high voltages or large currents. Also, do not wire power lines together with or parallel to Power Controller wiring. Using shielded cables and using separate conduits or ducts is recommended.
- Attach a surge suppressor or noise filter to peripheral devices that generate noise (in particular, motors, transformers, solenoids, magnetic coils or other equipment that have an inductance component).
- When a noise filter is used at the power supply, first check the voltage or current, and attach the noise filter as close as possible to the Power Controller.

### Cleaning

- Do not use paint thinner or similar chemical to clean with. Use commercially available standard grade alcohol.

### Storage

- Store the Power Controller within the rated ambient temperature.

## Precautions for Correct Use

### Installation Direction

For cooling efficiency, install the Power Controller in the correct direction. The G3PW generates a lot of heat, and it uses natural heat convection for cooling. Installing the Power Controller in the wrong direction may cause it to malfunction or to be damaged.

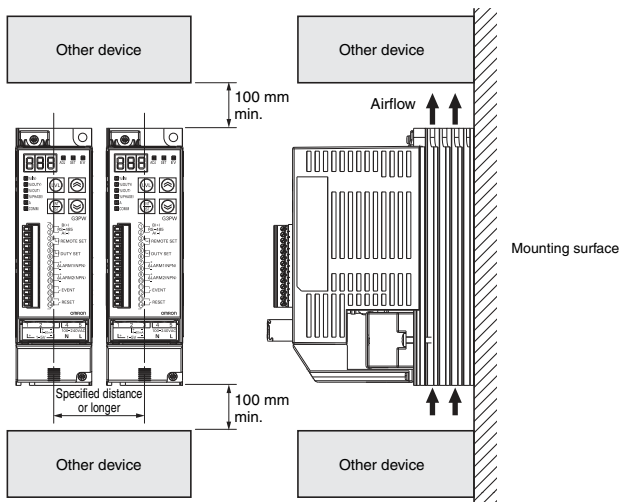
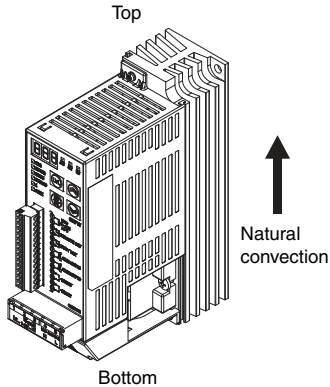

### Wiring the Power Supply and Load Circuits

The G3PW will not operate correctly if the wiring is not correct. The failure detection function of the G3PW will stop the output from operating.

Connect the AC power supply to power supply terminals 4 (N) and 5 (L).

Connect the load to load terminal T1 and to the power supply, and then connect the power supply to load terminal L1 through a fast-acting fuse.

The AC power supply ground polarity and the G3PW terminal block polarity are not related, but connect the 4 (N) and 5 (L) terminals on the command input/power supply terminal block and the T1 and L1 terminals of the load terminal block to power supplies with the same phases.

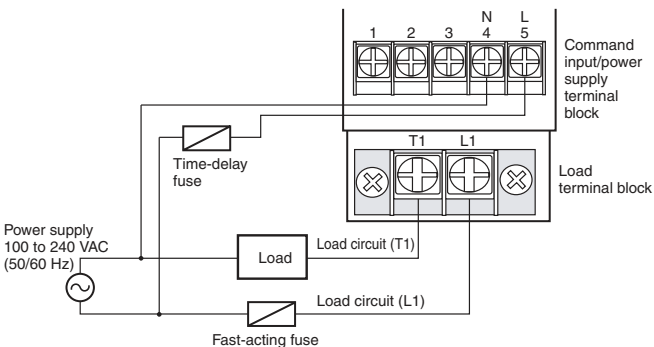

### Wiring the Load Terminal Block

#### Recommended Wires

When connecting to the load terminals, use the specified wire size for each model of Power Controller.

Model	Recommended wire size	Tightening torque	Terminal screws
G3PW-A220	AWG 18 to 10	1.8 N·m	M4
G3PW-A245	AWG 6 *	2.8 N·m	M5
G3PW-A260			

\* Crimp terminals that conform to UL and CSA specifications must be used.

#### Recommended Crimp Terminals

- Either use insulated crimp terminals or cover the crimp terminals with insulating sleeves.
- Always use the following crimp terminals to wire the load terminals.
- Do not connect more than two crimp terminals to one terminal screw.



Model	A (mm)
G3PW-A220	9.5 max.
G3PW-A245/A260	12 max.

#### Recommended Fuses

Recommended models Type	Super-rapid Fuse (Fuji Electric)		Fuse Holder (Fuji Electric)
	Fast-acting fuses *	For 20 A	CR6L-20/UL
For 45 A		CR6L-50/UL	
For 60 A		CR6L-75/UL	CMS-5

\* Ask your OMRON representative for UL certified products.

#### Time-delay fuses specifications

Type	Specification
Time-delay fuses	250 VAC, 2 A

### Command Input and Power Supply Terminal Wiring Voltage Input (1 to 5 VDC)

When using a voltage input, connect the positive and negative signal wires to terminals 1 and 3, respectively.

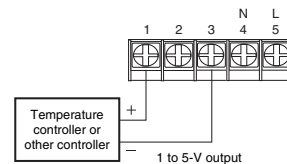

### Current Input (4 to 20 mA DC)

When using current input, connect the positive and negative signal wires to terminals 2 and 3, respectively.

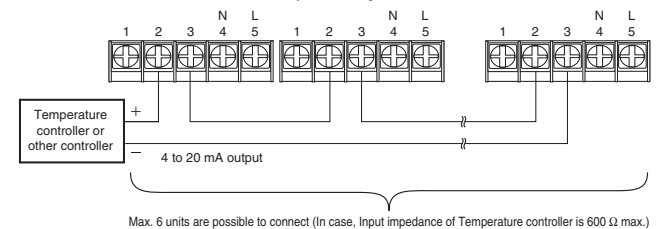

Max. 6 units are possible to connect (In case, Input impedance of Temperature controller is 600 Ω max.)

**Note:** If you connect more than one G3PW Controller for current input, do not connect the negative terminal of the event input/reset input (Ⓢ/Ⓢ) and the current input terminal -3 as negative commons on the G3PW Controllers. If you do, the second and later G3PW Controllers may not operate.

## ON/OFF Voltage Input (0 or 5 VDC)

When using an ON/OFF voltage input, connect the positive and negative signal wires to terminals 1 and 3, respectively and apply a command voltage that is 0 or 5V.

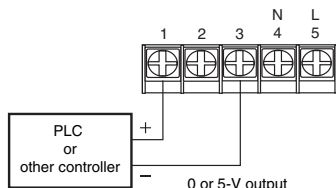

The G3PW may be damaged if a command voltage that is higher than 5 V is applied. If it is necessary to apply more than 5 V, split the voltage as shown below by inserting resistance in the line to terminal 1 and applying the voltage across terminals 1 and 3. The internal impedance between terminals 1 and 3 is 30.1 kΩ.

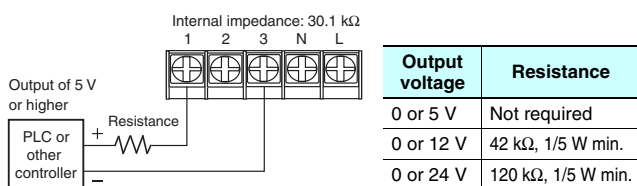

## Command Input and Power Supply Wire Sizes

Model	Recommended wire diameter	Tightening torque	Terminal screws
All models	AWG 18 to 14	0.8 to 1.0 N·m	M3.5

## Recommended Crimp Terminals

Always use the following crimp terminals (for M3.5) to wire to the command input and power supply terminals.

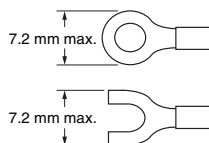

## Wiring the Control Terminal Block

### Recommended Wire Sizes and Connection Method

G3PW-A2□□E□-S (Models with terminal blocks with small slotted screws)

G3PW-A2□□E□-C (Models with screwless clamp terminal block)

### Wire Sizes for Control Terminals (Models with Small Slotted Screws or Screwless Clamp Terminals)

Model	Recommended wire diameter	Tightening torque	Terminal screws
All models	AWG 26 to 16	0.22 N·m	M2

- Use copper AWG 26 to 16 twisted-pair cable when connecting the wires directly.
- Strip the wire sheathing for the following lengths, according to the connector type.
  - Small slotted screw terminals: 7 mm
  - Screwless clamp terminals: 9 mm
- When using twisted wires, it is recommended that you attach a ferrule with an insulating cover that conforms to DIN 46228-4 and connect the ferrule to the terminal.
- Use shielded twisted-pair wires for RS-485 communications wires. A maximum of 500 m total of wiring can be used.

## Failure Detection Wiring

Sufficiently consider the safety design of the system design so that the load circuit is turned OFF using the alarm output when a failure is detected in the G3PW.

## Terminal Names

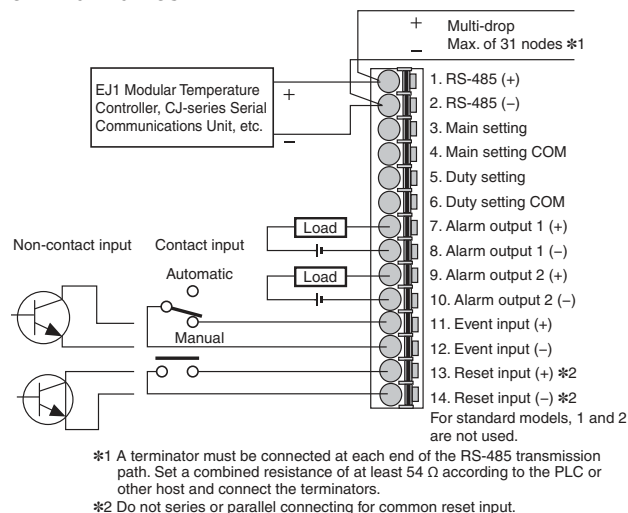

## Wiring Inputs for External Settings

- Wiring to Adjust the Main Setting

Use a G32X-V2K Variable Resistor to adjust the main setting.

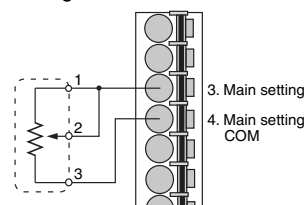

- Wiring to Adjust the Duty Setting

Use a G32X-V2K Variable Resistor to adjust the duty setting.

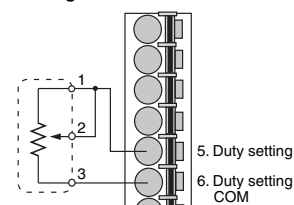

## Alarm Outputs

Output status	Open collector
Number of outputs	2
Maximum operating voltage	30 VDC
Maximum load current	50 mA
Maximum residual voltage	1.5 V
Maximum leakage current	0.4 mA

## Wiring an External Noise Filter

Always insert a noise filter in the power supply lines to the G3PW.

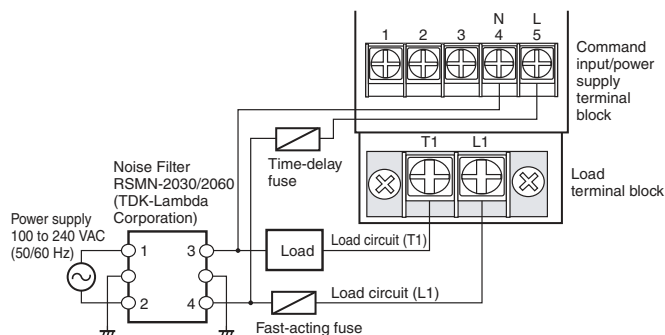

## Grounding

Always ground the Power Controller to 100 Ω or less. There are no ground terminals provided, so use the heat sink mounting screws as ground terminals.

## Digital Temperature Controller

# E5CC/E5CC-B/E5CC-U (48 x 48 mm)

**Large White PV Display That's Easier to Read.  
Easy to Use, from Model Selection to  
Setup and Operation.  
Models with Push-In Plus Terminal  
Blocks Added to Lineup.**

- The white PV display with a height of 15.2 mm improves visibility.
- High-speed sampling at 50 ms.
- Select from models with screw terminal blocks, models with Push-In Plus terminal blocks for reduced wiring work, and Plug-in Models that can be removed from the terminal block.
- Short body with depth of only 60 mm. (Screw Terminal Blocks)
- Easy connections to a PLC with programless communications. Use component communications to link Temperature Controllers to each other.
- Set up the Controller without wiring the power supply by connecting to the computer with a Communications Conversion Cable (sold separately). Setup is easy with the CX-Thermo (sold separately).



\* CSA conformance evaluation by UL.



48 48 mm  
Screw Terminal  
Blocks  
E5CC

48 48 mm  
Push-In Plus  
Terminal Blocks  
E5CC-B

48 48 mm  
Plug-in Models  
E5CC-U

Refer to your OMRON website for the most recent information on applicable safety standards.

## Digital Temperature Controller

# E5EC/E5EC-B/E5AC (48 x 96 mm/96 x 96 mm)

**Large White PV Display That's Easier to Read.  
Easy to Use, from Model Selection to  
Setup and Operation.  
Models with Push-In Plus Terminal  
Blocks Added to 48 x 96-mm Lineup.**

- A white LCD PV display with a height of approx. 18 mm for the E5EC/E5EC-B and 25 mm for the E5AC improves visibility.
- High-speed sampling at 50 ms.
- With 48 x 96-mm Controllers, you can select between screw terminal blocks or Push-In Plus terminal blocks to save wiring work.
- Short body with depth of only 60 mm. (Screw Terminal Blocks)
- Easy connections to a PLC with programless communications. Use component communications to link Temperature Controllers to each other.
- Tool ports are provided both on the top panel and the front panel. Set up the Controller without wiring the power supply by connecting to the computer with a Communications Conversion Cable (sold separately). Setup is easy with the CX-Thermo (sold separately).



\* CSA conformance evaluation by UL.



48 96 mm  
Screw Terminal  
Blocks  
E5EC

48 96 mm  
Push-In Plus  
Terminal  
Blocks  
E5EC-B

96 96 mm  
Screw Terminal Blocks  
E5AC

Refer to your OMRON website for the most recent information on applicable safety standards.

## Programmable Temperature Controller (Digital Controller)

# E5CC-T (48 x 48 mm)

**Programmable Controllers Join the E5□C Series!  
Program up to 256 segments can handle a  
wide variety of applications.**

- Set up to 8 Programs (Patterns) with 32 Segments (Steps) Each
- The white PV display with a height of 15.2 mm improves visibility.
- High-speed sampling at 50 ms.
- Models are available with up to 3 auxiliary outputs, up to 4 event inputs, and a transfer output to cover a wide range of applications.
- Short body with depth of only 60 mm.
- Set up the Controller without wiring the power supply by connecting to the computer with a Communications Conversion Cable (sold separately). Setup is easy with the CX-Thermo (sold separately).
- Easy connections to a PLC with programless communications. Use component communications to link Temperature Controllers to each other.



\* CSA conformance evaluation by UL.



48 48 mm  
E5CC-T

Refer to your OMRON website for the most recent information on applicable safety standards.

## Programmable Temperature Controller (Digital Controller)

# E5EC-T/E5AC-T (48 x 96 mm/96 x 96 mm)

**Programmable Controllers Join the E5□C Series!  
Program up to 256 segments can handle a  
wide variety of applications.**

- Set up to 8 Programs (Patterns) with 32 Segments (Steps) Each
- A white LCD PV display with a height of approx. 18 mm for the E5EC-T and 25 mm for the E5AC-T improves visibility.
- Tool ports are provided both on the top panel and the front panel. Set up the Controller without wiring the power supply by connecting to the computer with a Communications Conversion Cable (sold separately). Setup is easy with the CX-Thermo (sold separately).
- High-speed sampling at 50 ms.
- Models are available with up to 4 auxiliary outputs, up to 6 event inputs, and a transfer output to cover a wide range of applications.
- Short body with depth of only 60 mm.
- Easy connections to a PLC with programless communications. Use component communications to link Temperature Controllers to each other.
- The new position-proportional control models allow you to control valves as well.



\* CSA conformance evaluation by UL.



48 96 mm  
E5EC-T



96 96 mm  
E5AC-T

Refer to your OMRON website for the most recent information on applicable safety standards.

## Solid State Relays for Heaters

# Single-phase G3PE

**Compact, Slim-profile SSRs with Heat Sinks. Models with No Zero Cross for a Wide Range of Applications.**

- RoHS compliant.
- Models also available with no zero cross
- Surge pass protection improved surge dielectric strength for output currents. (OMRON testing)
- Compact with a slim profile.
- Mount to DIN Track or with screws.
- Conforms to UL, CSA, and EN standards (TÜV certification).

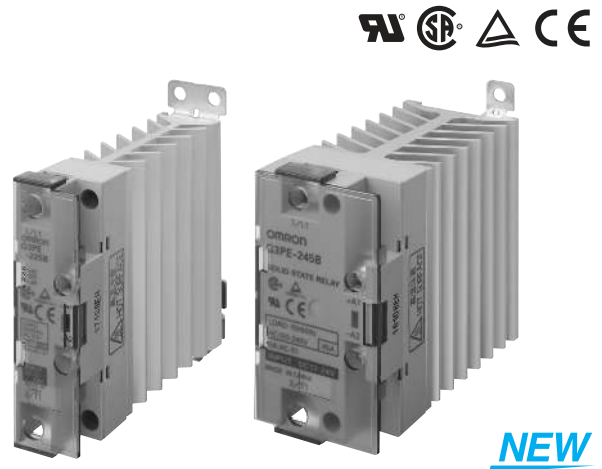

## Solid State Contactors for Heaters

# Three-phase G3PE

**Compact, Slim-profile SSRs with Heat Sinks. Solid State Contactors for Three-phase Heaters Reduced Installation Work with DIN Track Mounting.**

- RoHS compliant.
- Surge pass protection improved surge dielectric strength for output currents. (OMRON testing)
- Slim design with 3-phase output and built-in heat sinks.
- DIN Track mounting types and screw mounting types are available. All DIN Track mounting types mount to DIN Track (applicable DIN Track: TR35-15Fe (IEC 60715)).
- Conforms to UL, CSA, and EN standards (TÜV certification).



# Warranty and Application Considerations

## Read and Understand This Catalog

Please read and understand this catalog before purchasing the products. Please consult your OMRON representative if you have any questions or comments.

## Warranty and Limitations of Liability

### WARRANTY

OMRON's exclusive warranty is that the products are free from defects in materials and workmanship for a period of one year (or other period if specified) from date of sale by OMRON.

OMRON MAKES NO WARRANTY OR REPRESENTATION, EXPRESS OR IMPLIED, REGARDING NON-INFRINGEMENT, MERCHANTABILITY, OR FITNESS FOR PARTICULAR PURPOSE OF THE PRODUCTS. ANY BUYER OR USER ACKNOWLEDGES THAT THE BUYER OR USER ALONE HAS DETERMINED THAT THE PRODUCTS WILL SUITABLY MEET THE REQUIREMENTS OF THEIR INTENDED USE. OMRON DISCLAIMS ALL OTHER WARRANTIES, EXPRESS OR IMPLIED.

### LIMITATIONS OF LIABILITY

OMRON SHALL NOT BE RESPONSIBLE FOR SPECIAL, INDIRECT, OR CONSEQUENTIAL DAMAGES, LOSS OF PROFITS, OR COMMERCIAL LOSS IN ANY WAY CONNECTED WITH THE PRODUCTS, WHETHER SUCH CLAIM IS BASED ON CONTRACT, WARRANTY, NEGLIGENCE, OR STRICT LIABILITY.

In no event shall the responsibility of OMRON for any act exceed the individual price of the product on which liability is asserted.

IN NO EVENT SHALL OMRON BE RESPONSIBLE FOR WARRANTY, REPAIR, OR OTHER CLAIMS REGARDING THE PRODUCTS UNLESS OMRON'S ANALYSIS CONFIRMS THAT THE PRODUCTS WERE PROPERLY HANDLED, STORED, INSTALLED, AND MAINTAINED AND NOT SUBJECT TO CONTAMINATION, ABUSE, MISUSE, OR INAPPROPRIATE MODIFICATION OR REPAIR.

## Application Considerations

### SUITABILITY FOR USE

OMRON shall not be responsible for conformity with any standards, codes, or regulations that apply to the combination of products in the customer's application or use of the products.

Take all necessary steps to determine the suitability of the product for the systems, machines, and equipment with which it will be used.

Know and observe all prohibitions of use applicable to this product.

NEVER USE THE PRODUCTS FOR AN APPLICATION INVOLVING SERIOUS RISK TO LIFE OR PROPERTY WITHOUT ENSURING THAT THE SYSTEM AS A WHOLE HAS BEEN DESIGNED TO ADDRESS THE RISKS, AND THAT THE OMRON PRODUCTS ARE PROPERLY RATED AND INSTALLED FOR THE INTENDED USE WITHIN THE OVERALL EQUIPMENT OR SYSTEM.

## Disclaimers

### PERFORMANCE DATA

Performance data given in this catalog is provided as a guide for the user in determining suitability and does not constitute a warranty. It may represent the result of OMRON's test conditions, and the users must correlate it to actual application requirements. Actual performance is subject to the OMRON *Warranty and Limitations of Liability*.

### CHANGE IN SPECIFICATIONS

Product specifications and accessories may be changed at any time based on improvements and other reasons. Consult with your OMRON representative at any time to confirm actual specifications of purchased product.

### DIMENSIONS AND WEIGHTS

Dimensions and weights are nominal and are not to be used for manufacturing purposes, even when tolerances are shown.

**OMRON Corporation** Industrial Automation Company  
Tokyo, JAPAN

Contact: [www.ia.omron.com](http://www.ia.omron.com)

**Regional Headquarters**

**OMRON EUROPE B.V.**

Wegalaan 67-69-2132 JD Hoofddorp  
The Netherlands  
Tel: (31)2356-81-300/Fax: (31)2356-81-388

**OMRON ELECTRONICS LLC**

One Commerce Drive Schaumburg,  
IL 60173-5302 U.S.A.  
Tel: (1) 847-843-7900/Fax: (1) 847-843-7787

**OMRON ASIA PACIFIC PTE. LTD.**

No. 438A Alexandra Road # 05-05/08 (Lobby 2),  
Alexandra Technopark,  
Singapore 119967  
Tel: (65) 6835-3011/Fax: (65) 6835-2711

**OMRON (CHINA) CO., LTD.**

Room 2211, Bank of China Tower,  
200 Yin Cheng Zhong Road,  
PuDong New Area, Shanghai, 200120, China  
Tel: (86) 21-5037-2222/Fax: (86) 21-5037-2200

Authorized Distributor:

© OMRON Corporation 2008-2021 All Rights Reserved.  
In the interest of product improvement,  
specifications are subject to change without notice.

**CSM\_15\_1**  
**Cat. No. J176-E1-05**

Printed in Japan  
1221(0421)