

DIMENSIONS IN INCHES (MILLIMETERS)
DO NOT SCALE DRAWING

Dwg. No.
CWN-551-XX-0060

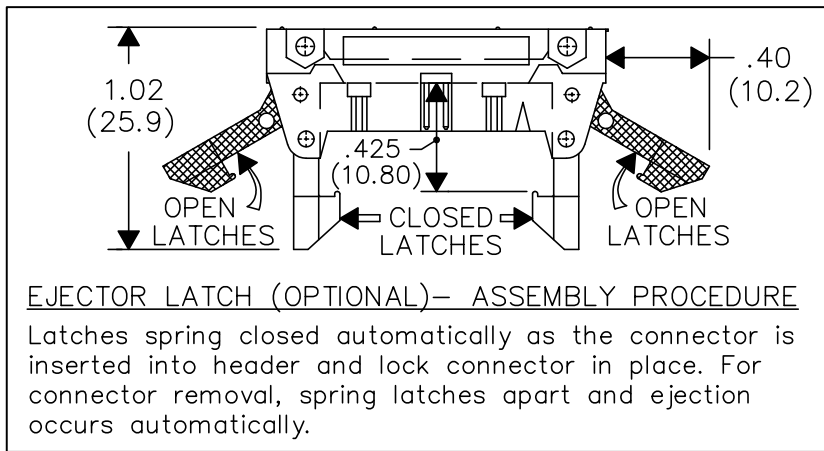

NOTES:

- 1) Dimensions are in inches; Dimensions in () are in millimeters.
- 2) Metric equivalents are given for general information only, and are based upon 1.00 inches equals (25.4) millimeters.
- 3) Polarizing feature (R2) does not appear on the 10 and 14 position connector.

MATERIALS:

PLASTIC PARTS- UL94V-0 Thermoplastic (Black, std.) flame retardant.
CONTACTS- Phosphor Bronze, standard
CONTACT PLATING- Selective gold plating, Standard; .000010 (min.) gold over .000050 nickel in mating area, and gold flash over .000050 nickel in remaining area.

OPERATING STANDARDS:

TEMPERATURE RATING- 125°C
CONTACT RATING- 1 AMPERE.
DIELECTRIC STRENGTH- OVER 500V.D.C. AT SEA LEVEL.
INSULATION RESISTANCE- Greater than 5 x 10⁹ ohms.

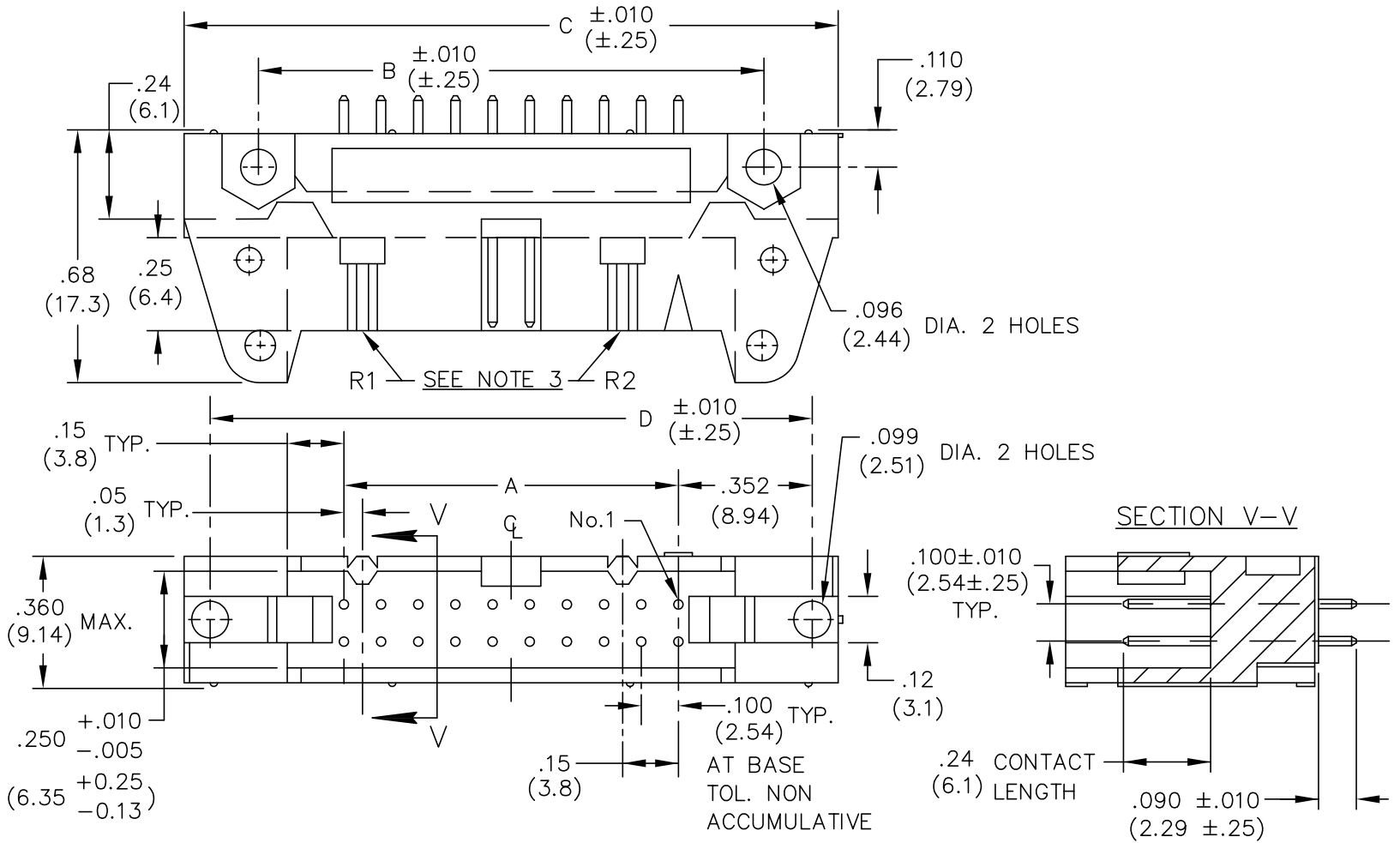

CUSTOMER DRAWING

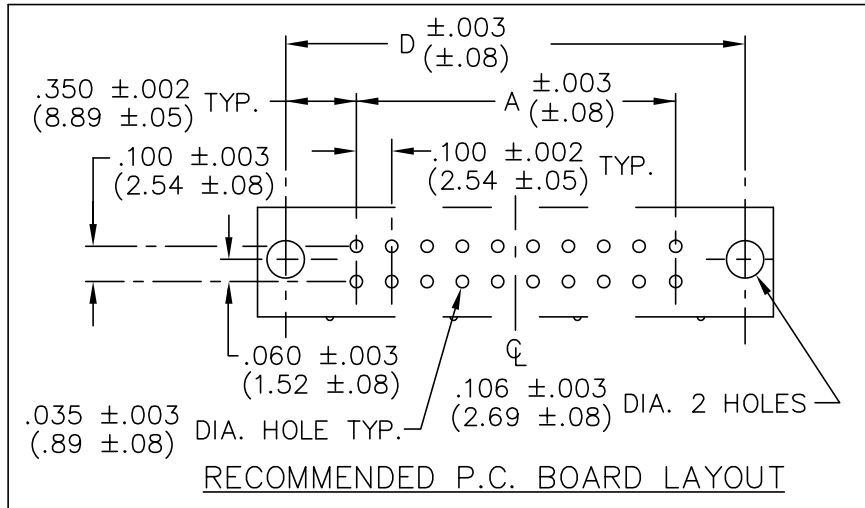

CONNECTOR DIMENSIONS				
XX NO. CONT's	A	B	C	D
10	.400 (10.16)	.860 (21.84)	1.260 (32.00)	1.100 (27.94)
14	.600 (15.24)	1.060 (26.92)	1.460 (37.08)	1.300 (33.02)
16	.700 (17.78)	1.160 (29.46)	1.560 (39.62)	1.400 (35.56)
20	.900 (22.86)	1.360 (34.54)	1.760 (44.70)	1.600 (40.64)
26	1.200 (30.48)	1.660 (42.16)	2.060 (52.32)	1.900 (48.26)
34	1.600 (40.64)	2.060 (52.32)	2.460 (62.48)	2.300 (58.42)
40	1.900 (48.26)	2.360 (59.44)	2.760 (70.10)	2.600 (66.04)
50	2.400 (60.96)	2.860 (72.64)	3.260 (82.80)	3.100 (78.74)
60	2.900 (73.66)	3.360 (85.34)	3.760 (95.50)	3.600 (91.44)

FORM-B4
REVISIONS
RELEASED FOR NEW SHOP. 0
DGW 6-08-2004
AH 6/23/04

CW INDUSTRIES
Southampton, Pa. 18966

TOLERANCES UNLESS OTHERWISE SPECIFIED

2 Place Decimal ±.010	METRIC
3 Place Decimal ±.005	1 Place Dec. ±.25mm
Angles ±1°	2 Place Dec. ±.13mm

Made for: CW IND.
Drawn by: DGW 6-08-2004
Checked by: GG 6-22-04
Approval: AH 6-23-04

Title: P.C.B. HEADER
.100 x .100 CENTERS
.102" STRAIGHT CONTACTS - ROUND W/POLAR. RIB(S) & LATCHES

Division: CONNECTOR
Dwg. No. CWN-551-XX-0060