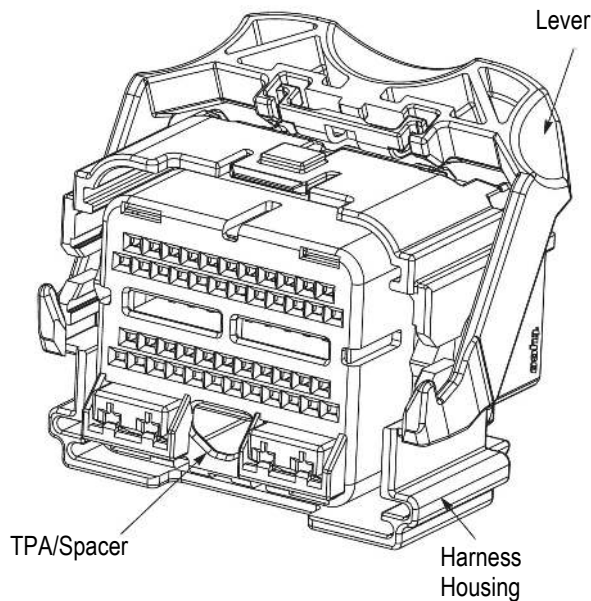

PMC2003 Harness Assemblies

Base Part Numbers	50-Way PCM2003 Connector Assemblies
1438129	Harness Assembly
1393364	Tyco Electronics .064 Terminal Assembly
1393365	
1642303	Molex 1.5 Terminal Assembly (Tyco Electronics Part Number)
33012-0002	Molex 1.5 Terminal Assembly (Molex Part Number)
1438126	Wire Dress Shield
1488572	
1488373	
Base Part Numbers	70-Way PCM2003 Connector Assemblies
1438136	Harness Assembly
1393364	Tyco Electronics .064 Terminal Assembly
1393365	
1642303	Molex 1.5 Terminal Assembly (Tyco Electronics Part Number)
33012-0002	Molex 1.5 Terminal Assembly (Molex Part Number)
1438133	Straddle
1488374	

Figure 1

1. INTRODUCTION

These instructions apply to the Power Control Module (PCM) 2003 Connector Assemblies listed in Figure 1.

2. ASSEMBLY PROCEDURE
2.1. Terminal Installation Procedure

1. Before inserting contacts into the harness assembly, be sure that the spacer (or TPA) is in the "preset" position." See Figure 2.

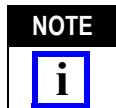

If the spacer is not in this position, proceed to Section 2.2, Terminal Replacement Procedure for instructions on returning the spacer (TPA) to the "preset position."

2. Grasp a terminal approximately 2cm behind the crimp and orient it as shown Figure 3 relative to the harness.
3. Insert the terminal into the harness and push on the terminal until an audible "click" is heard. Tug lightly on the wire to confirm the terminal is fully seated and assembled.
4. Repeat this process for the remaining terminals.
5. After the insertion of the final terminal, seat the TPA/spacer by grasping the assembly with the thumb(s) on the TPA and the forefinger(s) supporting the harness, as shown in Figure 4.
6. Press on the TPA until it clicks into the "fully seated position" (Figure 2). TPAs that do not seat indicate the possibility of a partially inserted terminal(s). If this occurs, remove the TPA (refer to Paragraph 2.2, Terminal Replacement Procedure), confirm terminals are properly seated, and reinstall TPA.
7. Align the four tabs on the wire dress with the four slots on the harnesses shown in Figure 5.

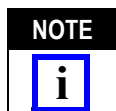

The orientation of the wire dress will vary with the application. Figure 6 is just one possible orientation.

8. Once the tabs are aligned with the slots, push the wire dress on evenly until all four tabs snap onto the harness. See Figure 6.
9. Visually confirm that the four tabs snapped into place. See Figure 6.
10. Next, confirm that the lever is in the "preset" or open position. Refer to Figure 7.

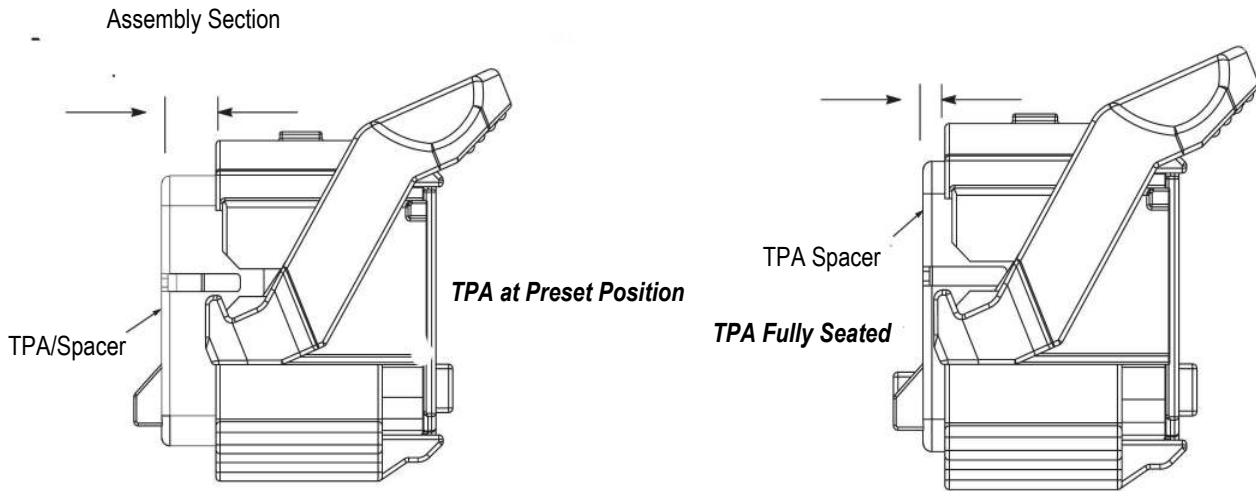

Figure 2

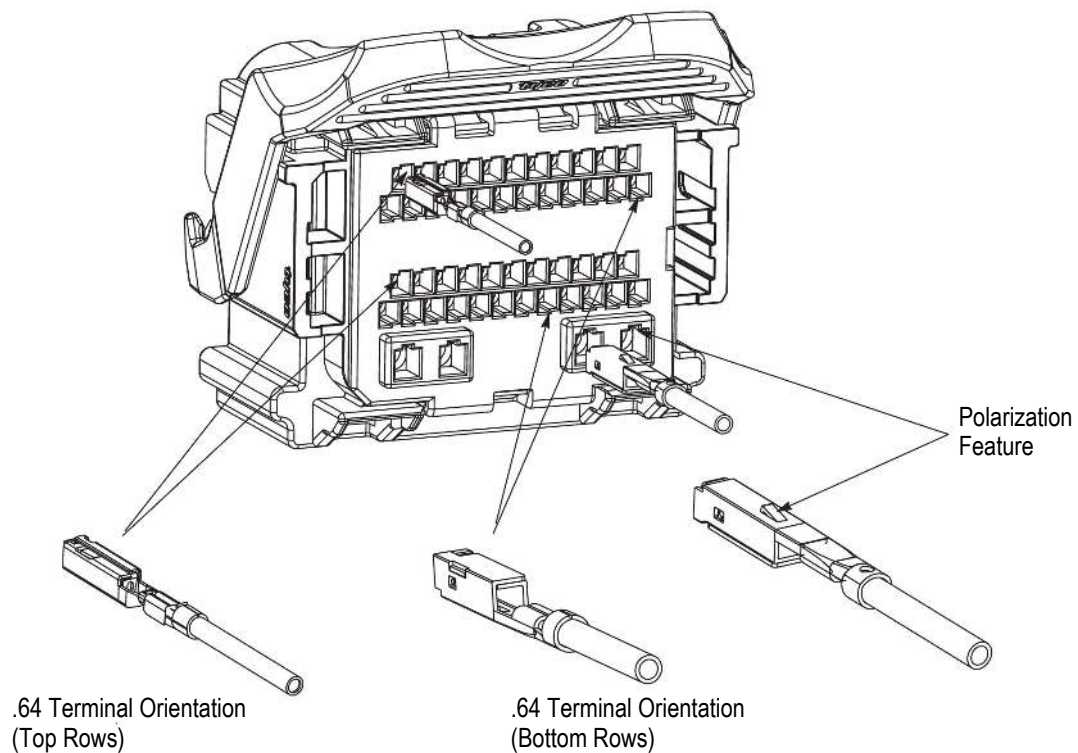

Figure 3



NOTE If the lever is not in the preset or open position, apply force to the lever with the other hand to rotate the lever back to its preset position. Refer to Figure 8

11. Orient the harness assembly to the header, as shown in Figure 9, and push the harness onto the header to the "pre-stage" position. This position is indicated by an audible click.



12. Once the harness is in the pre-stage position on the header, push on the lever until the lever seats against the header with an audible click. The harness / header should resemble Figure 10.

CAUTION Mating the connectors **WITHOUT** the use of the lever is not recommended. Employing the lever to mate the connectors should ensure proper, damage free assembly and function of the connector system.

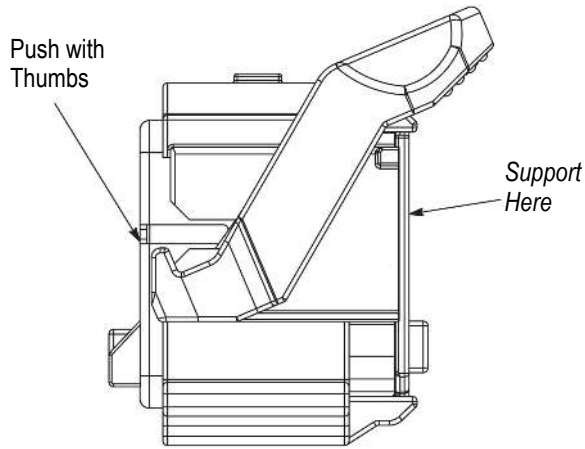
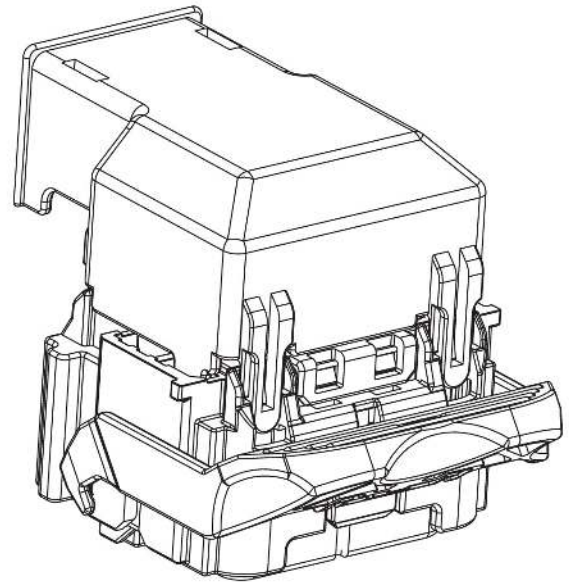
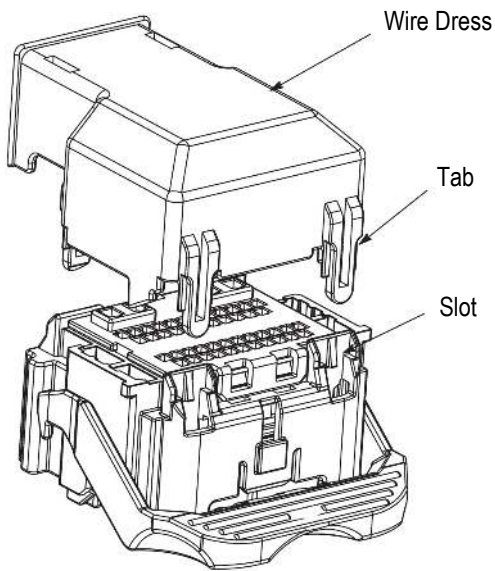

Figure 4



Wire Dress Mated With Harness
(Lever Not in Preset or Open Position for Purposes of Clarity)

Figure 6



Wire Dress Aligned With Harness
(Lever Not in Preset or Open Position for Purposes of Clarity)

Figure 5

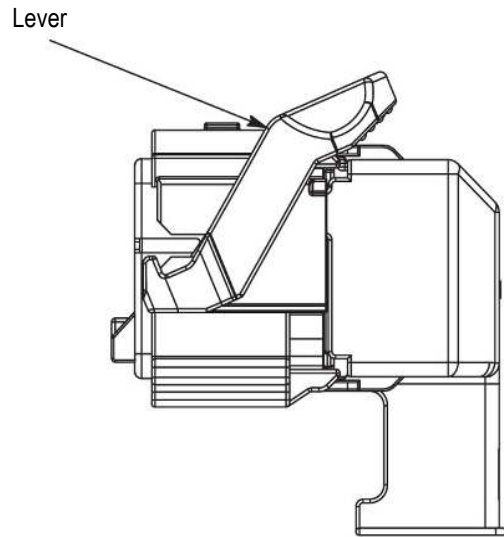

Lever in Preset or Open Position

Figure 7

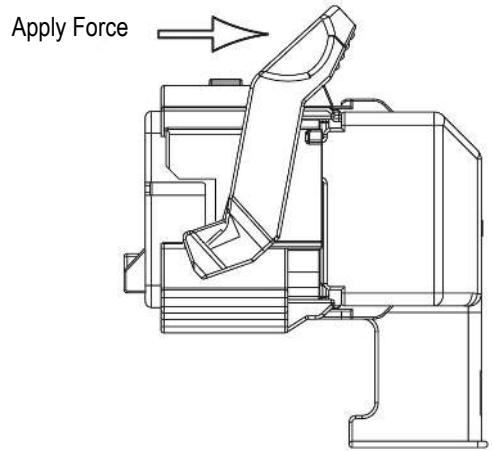

Lever NOT in Preset or Open Position

Figure 8

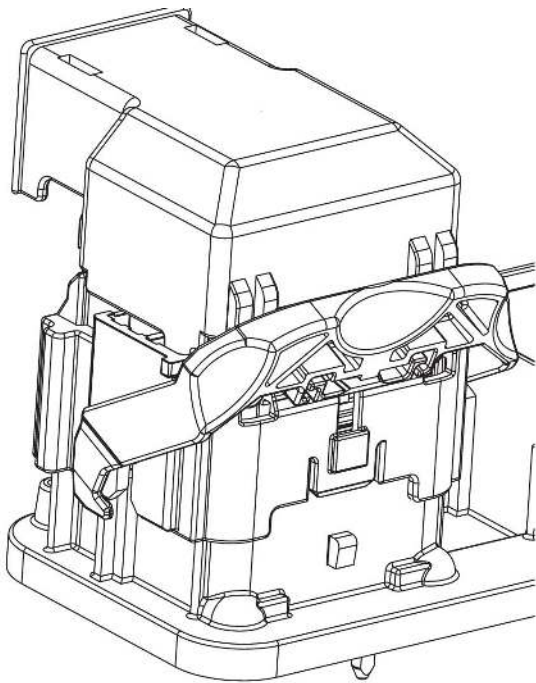

Harness Oriented to Header

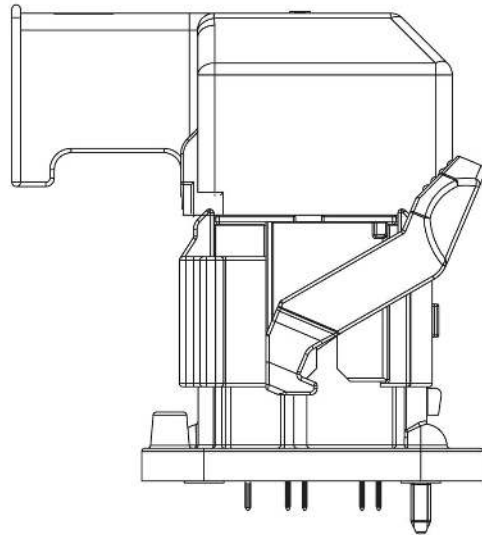

Harness in Pre-Stage Position

Figure 9

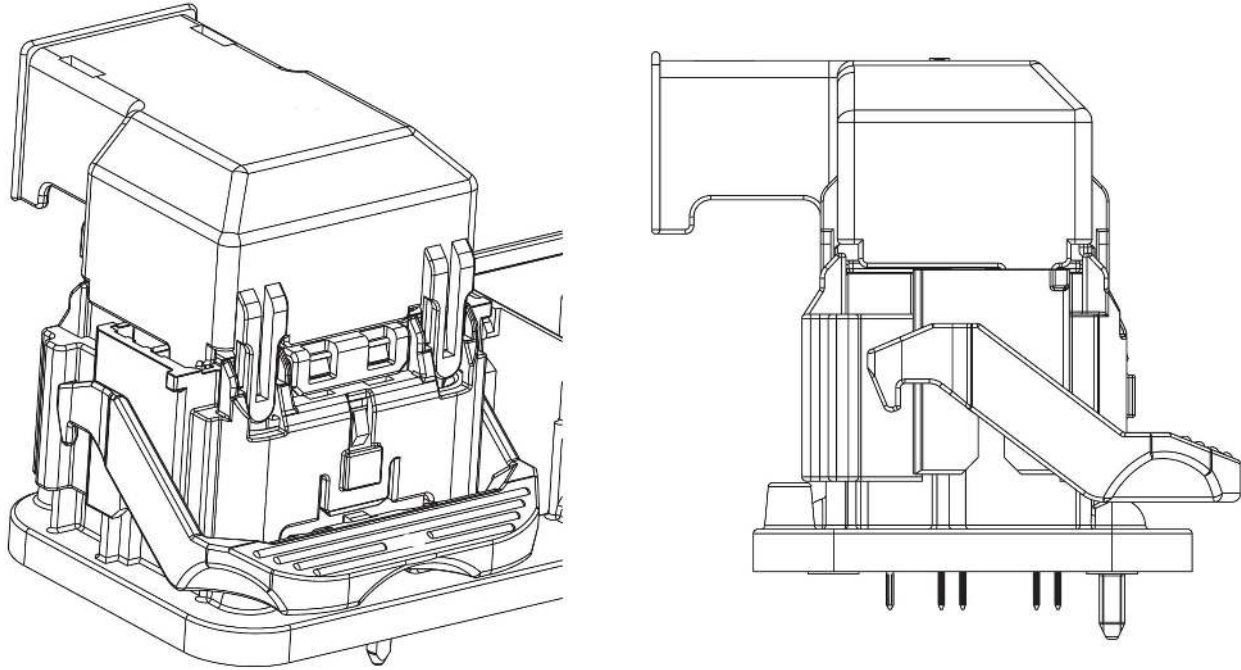

Harness Fully Seated on the Header

Figure 10

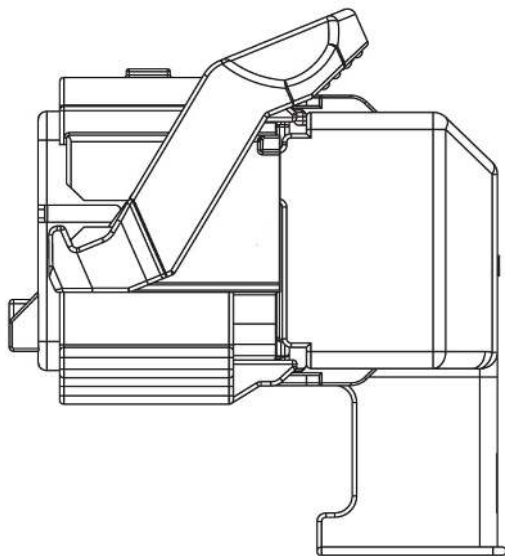

Figure 11

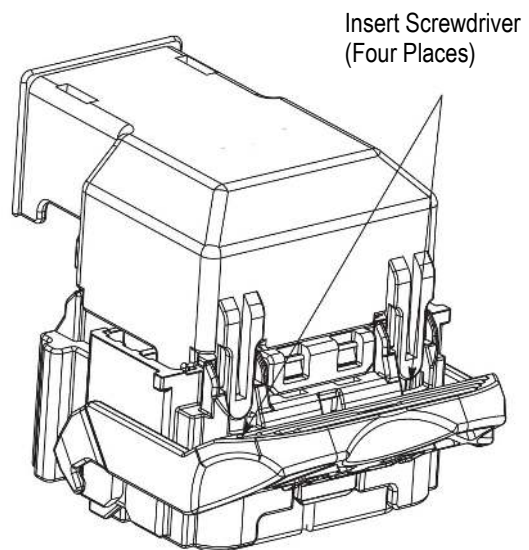

Figure 12

2.2. Terminal Replacement Procedure

Remove / replace a terminal from the harness assembly as described below.

A. Terminal Removal

1. Remove the harness from the header. Pull the lever away from the header until the lever clicks into the preset position. See Figure 11.

Once the lever is seated on the harness in the preset position, the harness is free to be removed from the header by grasping the harness housing (NOT the wire dress/shield) and pulling away from the header.

2. Remove the wire dress by placing a screwdriver under and between the wire dress tabs and the harness. Refer to Figure 12. Then carefully pry upward (rotate the handle toward the harness) on each of the four tabs until the wire dress is free of the harness.

3. Insert a small screwdriver in the positions shown in Figure 13 and pry the TPA away from the harness. On 70-Way connector assemblies, alternate from one slot to the other to aid in TPA removal.

4. With the TPA removed, push the wire of the terminal to be removed toward the harness to maximize the clearance between the terminal and the terminal latch.

5. Insert Removal Tool 1393477-6 into the mating face of the harness -- in the cavity to be reworked. Be sure the tool is located between the terminal and the terminal latch as shown in Figure 14.

6. Gently push the tool into the cavity to deflect the latch.

7. With the latch deflected, pull on the associated wire until the terminal is free of the harness.



Do NOT attempt to pull on the terminal until the latch is deflected.

B. Terminal Replacement

Set the TPA to the preset position and replace with a new terminal as described in Paragraph 2.1, Terminal Installation Procedure.

3. REVISION SUMMARY

Since the previous release of this document, the TE logo was applied.

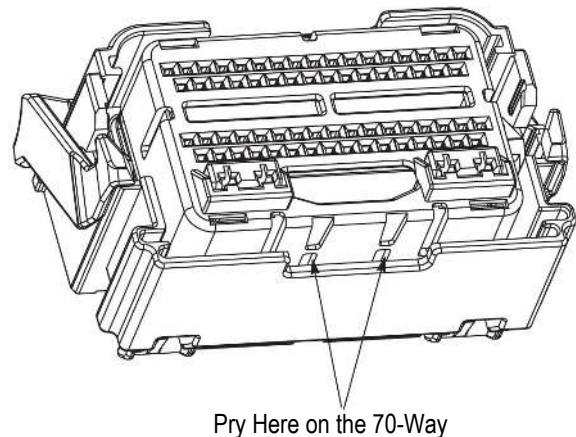
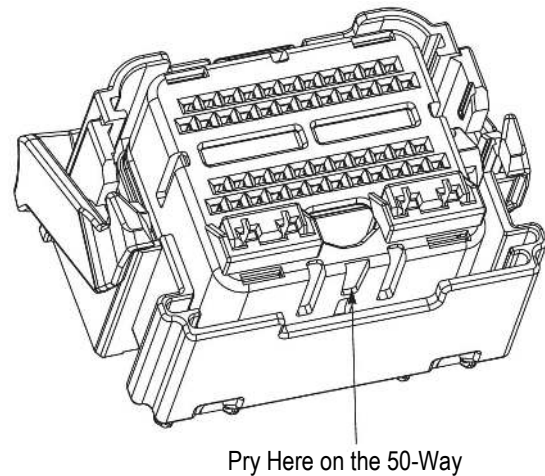

Figure 13

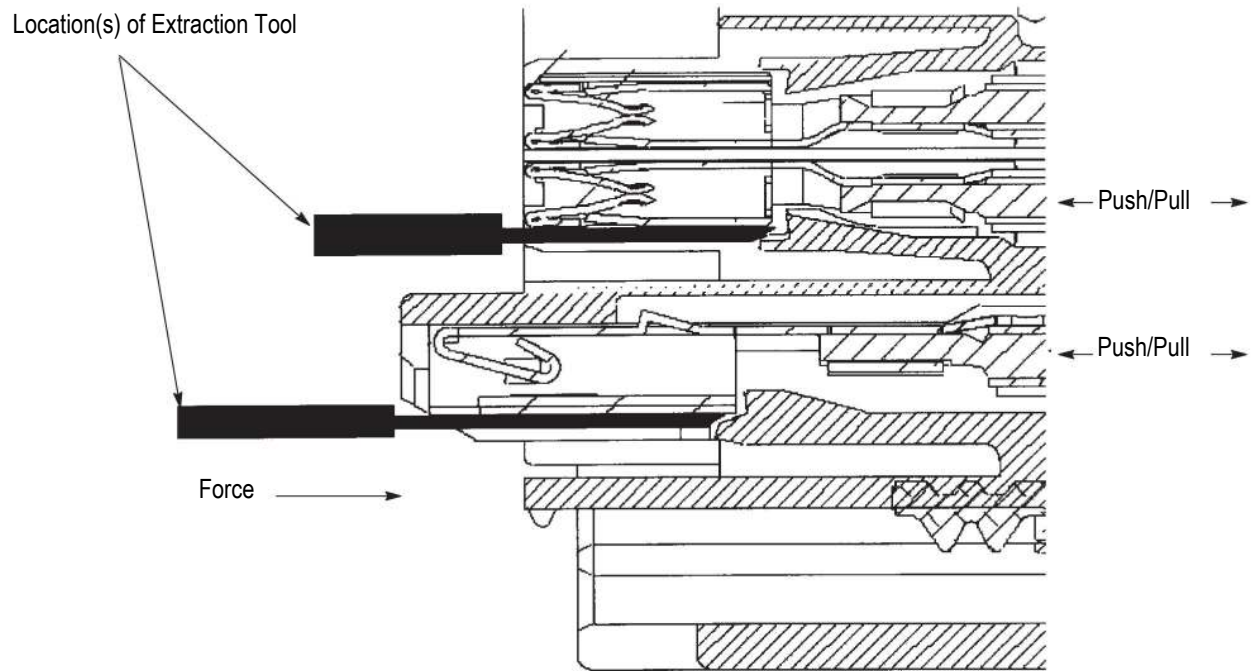

Figure 14