

10	9	8	7	6	5	4	3	2	1
PART NUMBER	DESCRIPTION								
180416-0001	HOLDER ASSEMBLY - NO CAP								
180416-0002	HOLDER ASSEMBLY - CAP WITH TAB								
180416-0003	HOLDER ASSEMBLY - CAP WITHOUT TAB								

HOLDER ASSEMBLY - NO CAP

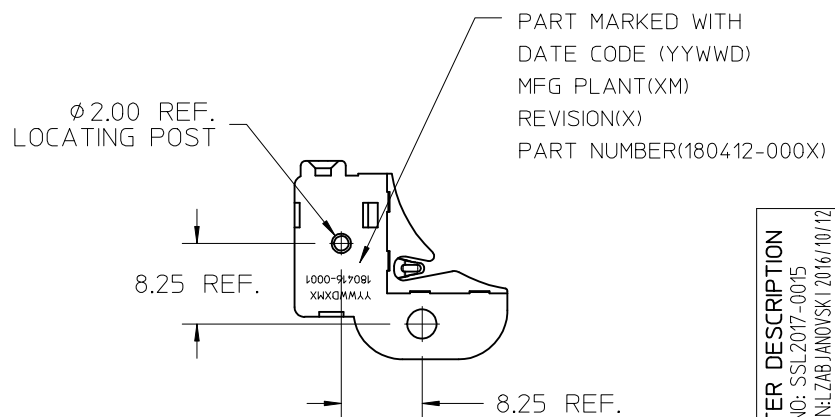
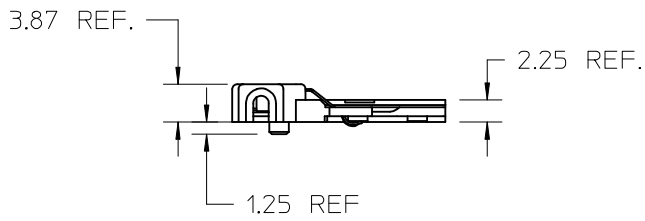
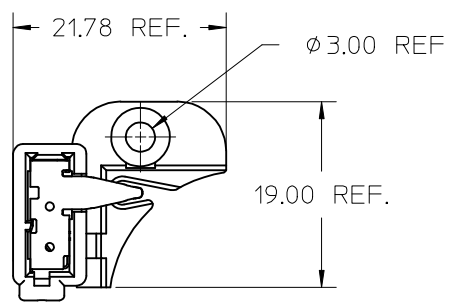

NOTES:

- MATERIALS: HOUSING: POLYAMIDE (PA66), GLASS FILLED, UL94V-0, 5VA (89992-0289); CAP: POLYAMIDE (PA66) UNFILLED, UL94V-0 (89992-0922); TERMINAL: COPPER ALLOY
- FINISHES: TERMINAL: NICKEL (Ni) UNDERPLATE 1.27 μ m, SELECT TIN (Sn) 2.54 μ m, SELECT GOLD (Au) 0.76 μ m
- PRODUCT SPECIFICATION: PS-180412-001
- PACKAGING SPECIFICATION: PK-180416-001
- APPLICATION SPECIFICATION: AS-180412-001
- FOR USE WITH: CITIZEN COB SERIES CLL040 OR CLL050 LEDS
- HOLDER ASSEMBLY AVAILABLE WITH OPTIONAL CAP SEE CHART FOR PART NUMBERS
- TWO HOLDER ASSEMBLIES ARE REQUIRED FOR EACH LED.
- WIRE GAUGE: 18 OR 20 AWG, SOLID OR STRANDED WITH TIN OVERCOAT. STRIP LENGTH 1CM.
- UL:0LFB2 UL496 FILE: E345583.



ISOMETRIC VIEW
Scale 1:1

SHEET 1 SCALE 2:1

ENTER DESCRIPTION EC NO: SSL2017-0015 /DRMHLZABJANOVSKI 2016/10/12 CHKD: APPR:GMEYER 2016/10/17 REV	QUALITY SYMBOLS $\nabla=0$ $\nabla=0$ $\nabla=0$	GENERAL TOLERANCES (UNLESS SPECIFIED) <table border="1"> <thead> <tr> <th></th> <th>mm</th> <th>INCH</th> </tr> </thead> <tbody> <tr> <td>4 PLACES</td> <td>\pm---</td> <td>\pm---</td> </tr> <tr> <td>3 PLACES</td> <td>\pm---</td> <td>\pm---</td> </tr> <tr> <td>2 PLACES</td> <td>\pm0.13</td> <td>\pm---</td> </tr> <tr> <td>1 PLACE</td> <td>\pm0.25</td> <td>\pm---</td> </tr> </tbody> </table>		mm	INCH	4 PLACES	\pm ---	\pm ---	3 PLACES	\pm ---	\pm ---	2 PLACES	\pm 0.13	\pm ---	1 PLACE	\pm 0.25	\pm ---	DIMENSION STYLE MM ONLY DRAWN BY: MCOLE DATE: 2012/01/30 CHECKED BY: MCOLE DATE: 2012/05/15 APPROVED BY:	SCALE 2:1 DESIGN UNITS METRIC THIRD ANGLE PROJECTION	TITLE 28 X 28MM & 38 X 38MM COB SERIES HOLDER ASSEMBLY
		mm	INCH																	
	4 PLACES	\pm ---	\pm ---																	
	3 PLACES	\pm ---	\pm ---																	
2 PLACES	\pm 0.13	\pm ---																		
1 PLACE	\pm 0.25	\pm ---																		
ANGULAR \pm 1/2°		MATERIAL NO. SEE CHART	DOCUMENT NO. SD-180416-001	SHEET NO. 1 OF 5																
DRAFT WHERE APPLICABLE MUST REMAIN WITHIN DIMENSIONS		THIS DRAWING CONTAINS INFORMATION THAT IS PROPRIETARY TO MOLEX INCORPORATED AND SHOULD NOT BE USED WITHOUT WRITTEN PERMISSION																		
B3		MOLEX INCORPORATED																		

ILLUSTRATION OF 28.0mm X 28.0mm LED WITH TWO HOLDER ASSEMBLIES - NO CAP

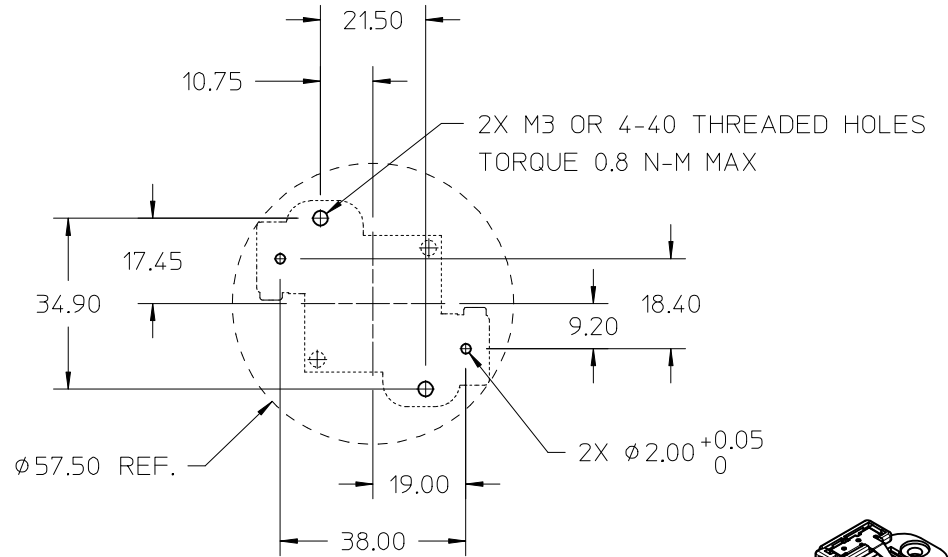
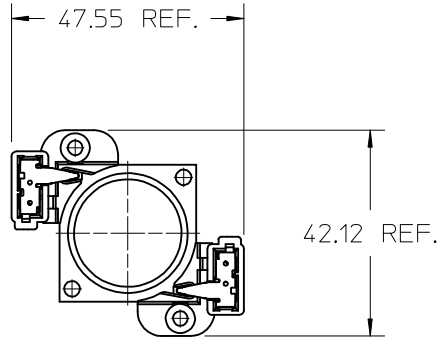

RECOMMENDED MOUNTING DIMENSIONS

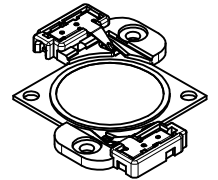

ISOMETRIC VIEW
Scale 1:1

SHEET 2 SCALE 1:1

ENTER DESCRIPTION EC NO: SSL2017-0015 DRWN: LZABJANOVSKI 2016/10/12 CHKD: APPR: GMEYER 2016/10/17 REV B3	QUALITY SYMBOLS ▽=0 ▽=0 ▽=0	GENERAL TOLERANCES (UNLESS SPECIFIED) mm INCH 4 PLACES ± --- ± --- 3 PLACES ± --- ± --- 2 PLACES ± 0.13 ± --- 1 PLACE ± 0.25 ± --- ANGULAR ± 1/2°	DIMENSION STYLE MM ONLY DRAWN BY DATE MCOLE 2012/01/30 CHECKED BY DATE MCOLE 2012/05/15 APPROVED BY DATE	SCALE 1:1 DESIGN UNITS METRIC THIRD ANGLE PROJECTION	TITLE 28 X 28MM & 38 X 38MM COB SERIES HOLDER ASSEMBLY
	DRAFT WHERE APPLICABLE MUST REMAIN WITHIN DIMENSIONS		MATERIAL NO. SEE CHART	DOCUMENT NO. SD-180416-001	SHEET NO. 2 OF 5
	THIS DRAWING CONTAINS INFORMATION THAT IS PROPRIETARY TO MOLEX INCORPORATED AND SHOULD NOT BE USED WITHOUT WRITTEN PERMISSION				
	MOLEX MOLEX INCORPORATED				

ILLUSTRATION OF 38.0mm X 38.0mm LED WITH TWO ASSEMBLIES - NO CAP

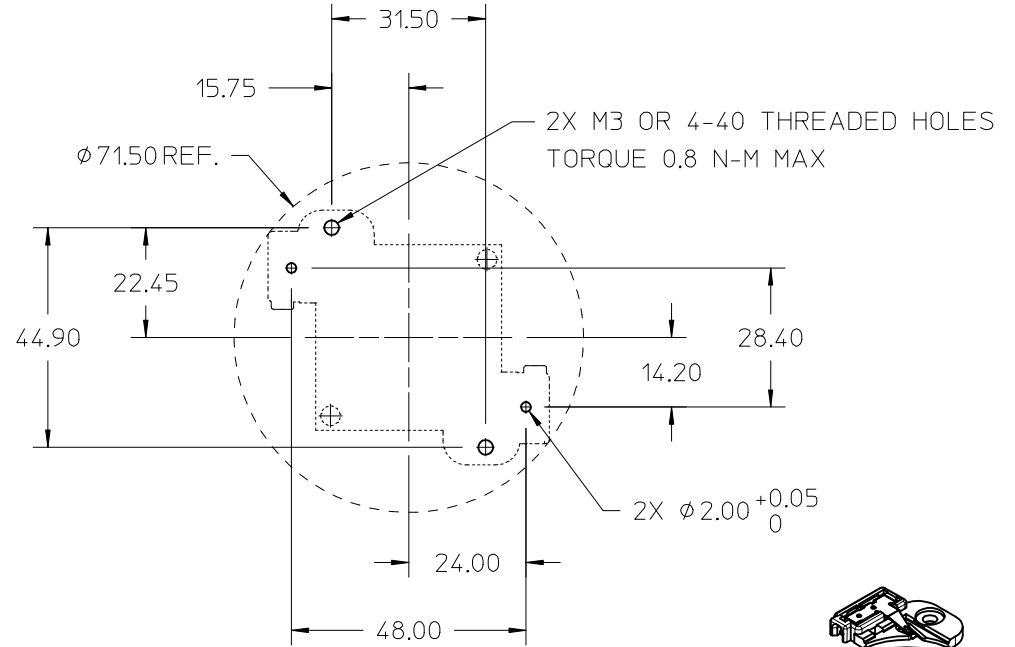
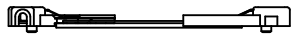
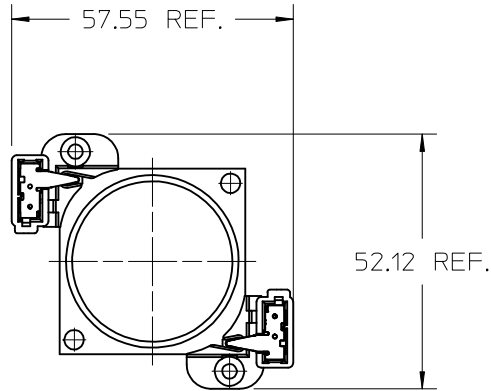

RECOMMENDED MOUNTING DIMENSIONS

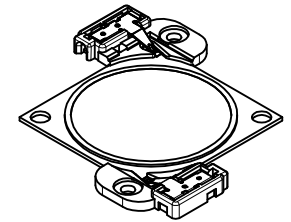

ISOMETRIC VIEW
Scale 1:1

SHEET 3 SCALE 1:1

ENTER DESCRIPTION EC NO: SSL2017-0015 DRWNL:ZAB.JANOVSKI 2016/10/12 CHKD: APPR:GMEYER 2016/10/17 REV	QUALITY SYMBOLS	GENERAL TOLERANCES (UNLESS SPECIFIED)		DIMENSION STYLE MM ONLY		SCALE 1:1	DESIGN UNITS METRIC	THIRD ANGLE PROJECTION	
	$\nabla F/0$	mm	INCH	DRAWN BY	DATE	TITLE 28 X 28MM & 38 X 38MM COB SERIES HOLDER ASSEMBLY			
	$\nabla E/0$	4 PLACES ± ---	± ---	MCOLE	2012/01/30				
	$\nabla E/0$	3 PLACES ± ---	± ---	CHECKED BY	DATE	MOLEX INCORPORATED DOCUMENT NO. SD-180416-001			
$\nabla E/0$	2 PLACES ± 0.13	± ---	MCOLE	2012/05/15					
	1 PLACE ± 0.25	± ---	APPROVED BY	DATE	MATERIAL NO.		SHEET NO.		
		ANGULAR ± 1/2°		SEE CHART		SD-180416-001		3 OF 5	
		DRAFT WHERE APPLICABLE MUST REMAIN WITHIN DIMENSIONS		THIS DRAWING CONTAINS INFORMATION THAT IS PROPRIETARY TO MOLEX INCORPORATED AND SHOULD NOT BE USED WITHOUT WRITTEN PERMISSION					

HOLDER ASSEMBLY - CAP WITH TAB

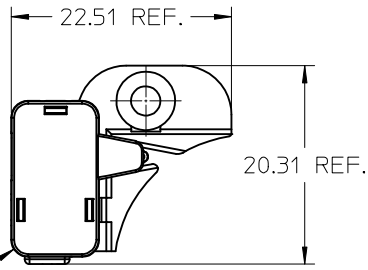

CAP WITH TAB
P/N 180417-0001
(SEE NOTE 7)

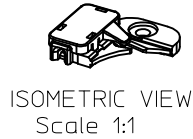
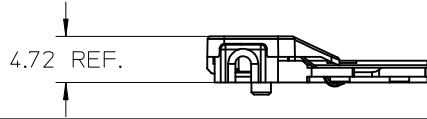

ISOMETRIC VIEW
Scale 1:1

HOLDER ASSEMBLY - CAP WITHOUT TAB

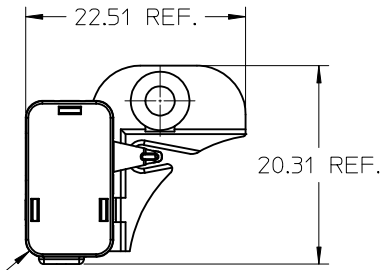

CAP WITHOUT TAB
P/N 180417-0002
(SEE NOTE 7)

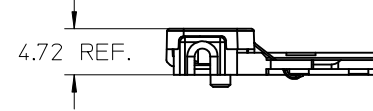

ISOMETRIC VIEW
Scale 1:1

ENTER DESCRIPTION EC NO: SSL2017-0015 DRWNL:ZAB,JANOVSKI 2016/10/12 CHKD: APPR:GMEYER 2016/10/17 B3	QUALITY SYMBOLS ▽=0 ▽=0 ▽=0	GENERAL TOLERANCES (UNLESS SPECIFIED) <table border="1"> <thead> <tr> <th></th> <th>mm</th> <th>INCH</th> </tr> </thead> <tbody> <tr> <td>4 PLACES</td> <td>± ---</td> <td>± ---</td> </tr> <tr> <td>3 PLACES</td> <td>± ---</td> <td>± ---</td> </tr> <tr> <td>2 PLACES</td> <td>± 0.13</td> <td>± ---</td> </tr> <tr> <td>1 PLACE</td> <td>± 0.25</td> <td>± ---</td> </tr> <tr> <td>0 PLACE</td> <td>± ---</td> <td>± ---</td> </tr> </tbody> </table>		mm	INCH	4 PLACES	± ---	± ---	3 PLACES	± ---	± ---	2 PLACES	± 0.13	± ---	1 PLACE	± 0.25	± ---	0 PLACE	± ---	± ---	DIMENSION STYLE MM ONLY DRAWN BY: MCOLE DATE: 2012/01/30 CHECKED BY: MCOLE DATE: 2012/05/15 APPROVED BY:	SCALE 2:1 DESIGN UNITS METRIC THIRD ANGLE PROJECTION	TITLE 28 X 28MM & 38 X 38MM COB SERIES HOLDER ASSEMBLY molex	MATERIAL NO. SEE CHART SIZE B	DOCUMENT NO. SD-180416-001	SHEET NO. 4 OF 5
		mm	INCH																							
	4 PLACES	± ---	± ---																							
	3 PLACES	± ---	± ---																							
	2 PLACES	± 0.13	± ---																							
1 PLACE	± 0.25	± ---																								
0 PLACE	± ---	± ---																								
DRAFT WHERE APPLICABLE MUST REMAIN WITHIN DIMENSIONS		THIS DRAWING CONTAINS INFORMATION THAT IS PROPRIETARY TO MOLEX INCORPORATED AND SHOULD NOT BE USED WITHOUT WRITTEN PERMISSION																								

10	9	8	7	6	
COB MFG	TYPE	DIM 'X'	DIM 'Y'	DIM 'Z'	DIM 'D'
CITIZEN	CLL040, CLL042, CLU044, CLU046, CLU048	28.0	28.0	0.90	24.5
LEXTAR	PB38H01.0	28.0	28.0	0.90	23.6
LUMILEDS	LUXEON 1211	28.0	28.0	1.00	21.0
SEOUL	ZC25, ZC40, ZC60	28.0	28.0	0.90	24.2
LG INNOTEK	40W/60W COB	28.0	28.0	0.82	24.5
VOSSL0H-SCHWABE	DMC12CC**D, DMC17CC**D	28.0	28.0	1.00	24.0
BRIDGELUX	V22	28.0	28.0	1.00	23.6

5	4	3	2	1	
COB MFG	TYPE	DIM 'X'	DIM 'Y'	DIM 'Z'	DIM 'D'
CITIZEN	CLL050, CLL052, CLU054, CLU056, CLU058	38.0	38.0	0.90	35.5
VOSSL0H-SCHWABE	DMC18Q***F	38.0	38.0	1.00	35.0

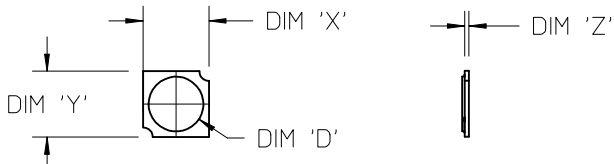

COB LED

ENTER DESCRIPTION EC NO: SSL2017-0015 DRWNL: ZABJANOVSKI 2016/10/12 CHKD: APPR: GMEYER 2016/10/17 REV	QUALITY SYMBOLS =0 =0	GENERAL TOLERANCES (UNLESS SPECIFIED) <table border="1"> <thead> <tr> <th></th> <th>mm</th> <th>INCH</th> </tr> </thead> <tbody> <tr> <td>4 PLACES</td> <td>± ---</td> <td>± ---</td> </tr> <tr> <td>3 PLACES</td> <td>± ---</td> <td>± ---</td> </tr> <tr> <td>2 PLACES</td> <td>± 0.13</td> <td>± ---</td> </tr> <tr> <td>1 PLACE</td> <td>± 0.25</td> <td>± ---</td> </tr> <tr> <td>0 PLACE</td> <td>± ---</td> <td>± ---</td> </tr> </tbody> </table>		mm	INCH	4 PLACES	± ---	± ---	3 PLACES	± ---	± ---	2 PLACES	± 0.13	± ---	1 PLACE	± 0.25	± ---	0 PLACE	± ---	± ---	DIMENSION STYLE MM ONLY DRAWN BY: MCOLE DATE: 2012/01/30 CHECKED BY: MCOLE DATE: 2012/05/15 APPROVED BY: DATE:	SCALE 1:1 DESIGN UNITS METRIC THIRD ANGLE PROJECTION	TITLE 28 X 28MM & 38 X 38MM COB SERIES HOLDER ASSEMBLY 	MATERIAL NO. SEE CHART SIZE B	DOCUMENT NO. SD-180416-001	SHEET NO. 5 OF 5
		mm	INCH																							
	4 PLACES	± ---	± ---																							
	3 PLACES	± ---	± ---																							
	2 PLACES	± 0.13	± ---																							
1 PLACE	± 0.25	± ---																								
0 PLACE	± ---	± ---																								
ANGULAR ±1/2°		DRAFT WHERE APPLICABLE MUST REMAIN WITHIN DIMENSIONS		THIS DRAWING CONTAINS INFORMATION THAT IS PROPRIETARY TO MOLEX INCORPORATED AND SHOULD NOT BE USED WITHOUT WRITTEN PERMISSION																						

10	9	8	7	6	5	4	3	2	1
PART NUMBER	DESCRIPTION								
180416-0001	HOLDER ASSEMBLY - NO CAP								
180416-0002	HOLDER ASSEMBLY - CAP WITH TAB								
180416-0003	HOLDER ASSEMBLY - CAP WITHOUT TAB								

HOLDER ASSEMBLY - NO CAP

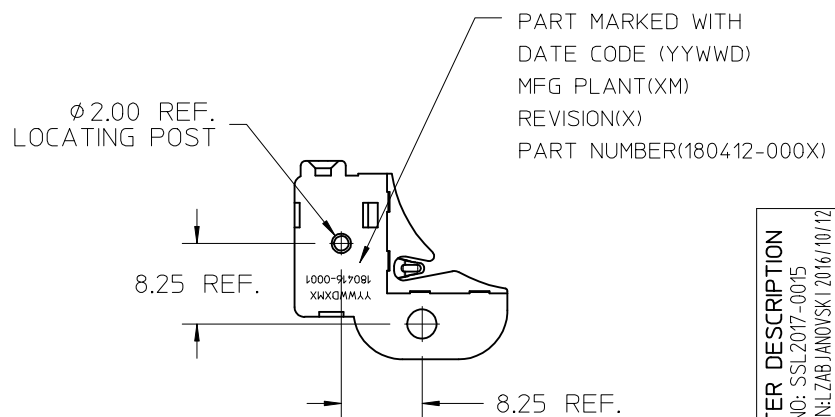
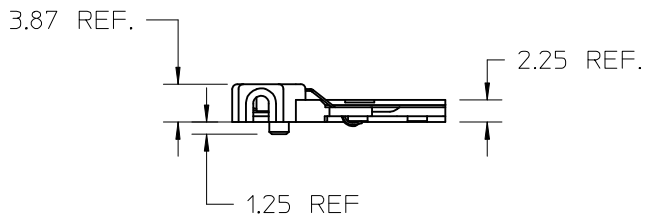
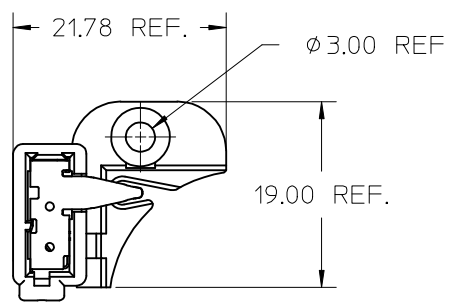

NOTES:

1. MATERIALS: HOUSING: POLYAMIDE (PA66), GLASS FILLED, UL94V-0, 5VA (89992-0289); CAP: POLYAMIDE (PA66) UNFILLED, UL94V-0 (89992-0922); TERMINAL: COPPER ALLOY
2. FINISHES: TERMINAL: NICKEL (Ni) UNDERPLATE 1.27 μ m, SELECT TIN (Sn) 2.54 μ m, SELECT GOLD (Au) 0.76 μ m
3. PRODUCT SPECIFICATION: PS-180412-001
4. PACKAGING SPECIFICATION: PK-180416-001
5. APPLICATION SPECIFICATION: AS-180412-001
6. FOR USE WITH: CITIZEN COB SERIES CLL040 OR CLL050 LEDS
7. HOLDER ASSEMBLY AVAILABLE WITH OPTIONAL CAP SEE CHART FOR PART NUMBERS
8. TWO HOLDER ASSEMBLIES ARE REQUIRED FOR EACH LED.
9. WIRE GAUGE: 18 OR 20 AWG, SOLID OR STRANDED WITH TIN OVERCOAT. STRIP LENGTH 1CM.
10. UL:0LFB2 UL496 FILE: E345583.



ISOMETRIC VIEW
Scale 1:1

SHEET 1 SCALE 2:1

ENTER DESCRIPTION EC NO: SSL2017-0015 /DRMHLZABJANOVSKI 2016/10/12 CHKD: APPR:GMEYER 2016/10/17 REV	QUALITY SYMBOLS $\nabla=0$ $\nabla=0$ $\nabla=0$	GENERAL TOLERANCES (UNLESS SPECIFIED) <table border="1"> <thead> <tr> <th></th> <th>mm</th> <th>INCH</th> </tr> </thead> <tbody> <tr> <td>4 PLACES</td> <td>\pm---</td> <td>\pm---</td> </tr> <tr> <td>3 PLACES</td> <td>\pm---</td> <td>\pm---</td> </tr> <tr> <td>2 PLACES</td> <td>\pm0.13</td> <td>\pm---</td> </tr> <tr> <td>1 PLACE</td> <td>\pm0.25</td> <td>\pm---</td> </tr> </tbody> </table>		mm	INCH	4 PLACES	\pm ---	\pm ---	3 PLACES	\pm ---	\pm ---	2 PLACES	\pm 0.13	\pm ---	1 PLACE	\pm 0.25	\pm ---	DIMENSION STYLE MM ONLY DRAWN BY: MCOLE DATE: 2012/01/30 CHECKED BY: MCOLE DATE: 2012/05/15 APPROVED BY:	SCALE 2:1 DESIGN UNITS METRIC THIRD ANGLE PROJECTION	TITLE 28 X 28MM & 38 X 38MM COB SERIES HOLDER ASSEMBLY
		mm	INCH																	
	4 PLACES	\pm ---	\pm ---																	
	3 PLACES	\pm ---	\pm ---																	
2 PLACES	\pm 0.13	\pm ---																		
1 PLACE	\pm 0.25	\pm ---																		
ANGULAR $\pm 1/2^\circ$		MATERIAL NO. SEE CHART	DOCUMENT NO. SD-180416-001	SHEET NO. 1 OF 5																
DRAFT WHERE APPLICABLE MUST REMAIN WITHIN DIMENSIONS		THIS DRAWING CONTAINS INFORMATION THAT IS PROPRIETARY TO MOLEX INCORPORATED AND SHOULD NOT BE USED WITHOUT WRITTEN PERMISSION																		
B3		MOLEX INCORPORATED																		

ILLUSTRATION OF 28.0mm X 28.0mm LED WITH TWO HOLDER ASSEMBLIES - NO CAP

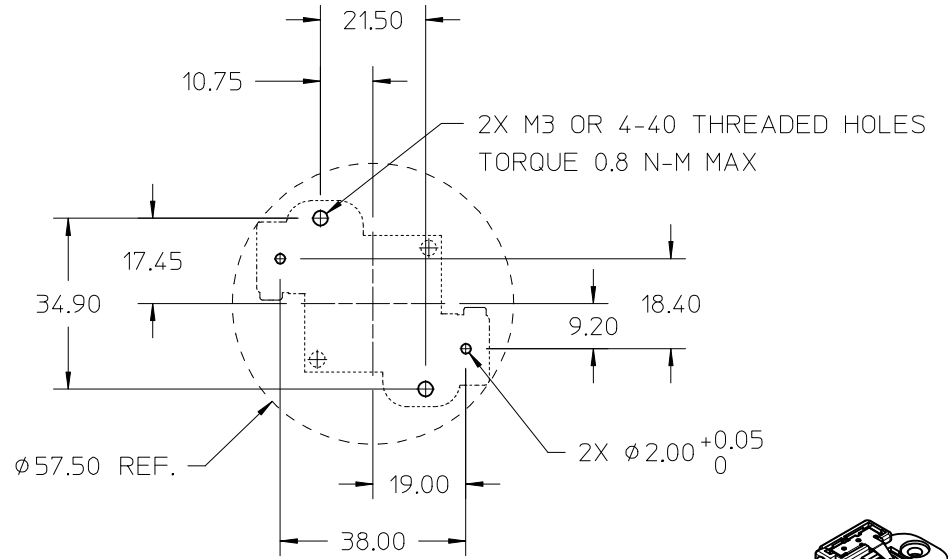
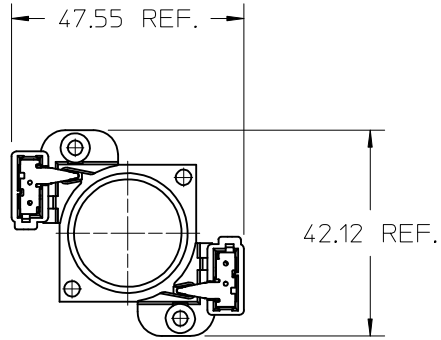

RECOMMENDED MOUNTING DIMENSIONS

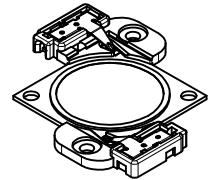

ISOMETRIC VIEW
Scale 1:1

SHEET 2 SCALE 1:1

ENTER DESCRIPTION ELC NO: SSL2017-0015 DRWN: LZABJANOVSKI 2016/10/12 CHKD: APPR: GMEYER 2016/10/17 REV B3	QUALITY SYMBOLS	GENERAL TOLERANCES (UNLESS SPECIFIED)		DIMENSION STYLE MM ONLY		SCALE 1:1	DESIGN UNITS METRIC	THIRD ANGLE PROJECTION
	▽=0	mm	INCH	DRAWN BY	DATE	TITLE		
	▽=0	4 PLACES ± ---	± ---	MCOLE	2012/01/30	28 X 28MM & 38 X 38MM		
	▽=0	3 PLACES ± ---	± ---	CHECKED BY	DATE	COB SERIES		
▽=0	2 PLACES ± 0.13	± ---	MCOLE	2012/05/15	HOLDER ASSEMBLY			
▽=0	1 PLACE ± 0.25	± ---	APPROVED BY	DATE	molex MOLEX INCORPORATED			
ANGULAR ± 1/2°		DRAFT WHERE APPLICABLE MUST REMAIN WITHIN DIMENSIONS		MATERIAL NO. SEE CHART		DOCUMENT NO. SD-180416-001		SHEET NO. 2 OF 5
THIS DRAWING CONTAINS INFORMATION THAT IS PROPRIETARY TO MOLEX INCORPORATED AND SHOULD NOT BE USED WITHOUT WRITTEN PERMISSION		SIZE B						

ILLUSTRATION OF 38.0mm X 38.0mm LED WITH TWO ASSEMBLIES - NO CAP

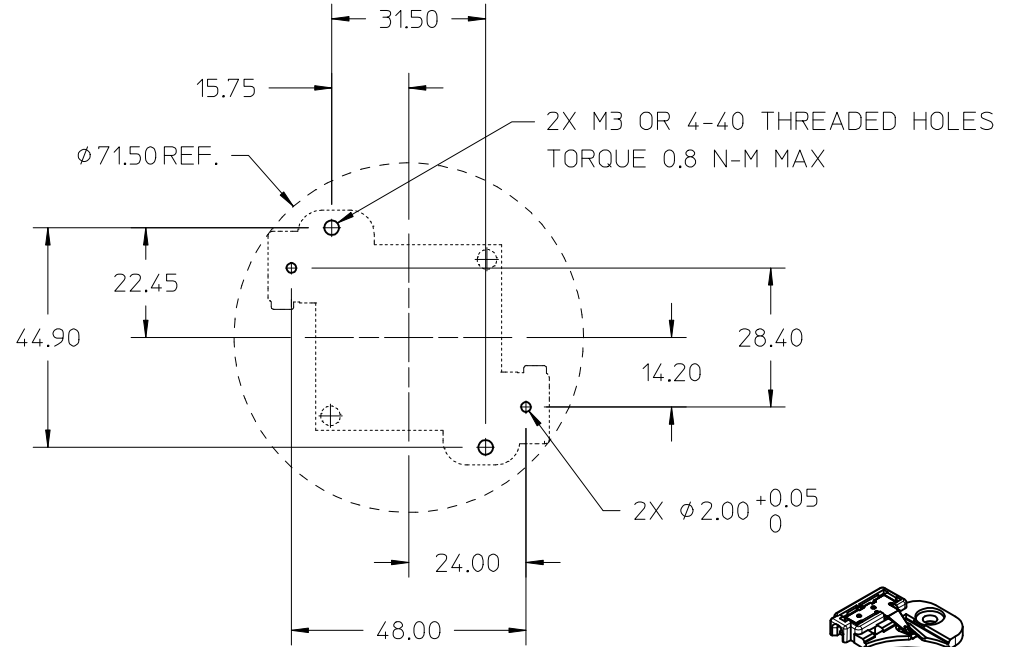
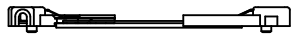
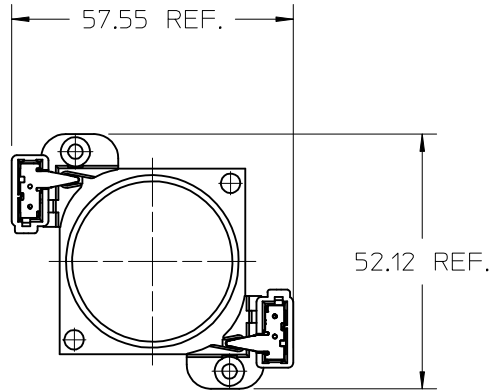

RECOMMENDED MOUNTING DIMENSIONS

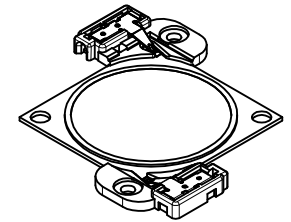

ISOMETRIC VIEW
Scale 1:1

SHEET 3 SCALE 1:1

ENTER DESCRIPTION EC NO: SSL2017-0015 DRWNL:ZAB.JANOVSKI 2016/10/12 CHKD: APPR:GMEYER 2016/10/17 REV	QUALITY SYMBOLS	GENERAL TOLERANCES (UNLESS SPECIFIED)		DIMENSION STYLE MM ONLY		SCALE 1:1	DESIGN UNITS METRIC	THIRD ANGLE PROJECTION	
	$\nabla F/0$	mm	INCH	DRAWN BY	DATE	TITLE			
	$\nabla F/0$	4 PLACES ± ---	± ---	MCOLE	2012/01/30	28 X 28MM & 38 X 38MM			
	$\nabla F/0$	3 PLACES ± ---	± ---	CHECKED BY	DATE	COB SERIES			
	2 PLACES ± 0.13	± ---	MCOLE	2012/05/15	HOLDER ASSEMBLY				
	1 PLACE ± 0.25	± ---	APPROVED BY	DATE	molex MOLEX INCORPORATED				
		ANGULAR ±1/2°		MATERIAL NO.		DOCUMENT NO.		SHEET NO.	
		DRAFT WHERE APPLICABLE MUST REMAIN WITHIN DIMENSIONS		SEE CHART		SD-180416-001		3 OF 5	
B3		THIS DRAWING CONTAINS INFORMATION THAT IS PROPRIETARY TO MOLEX INCORPORATED AND SHOULD NOT BE USED WITHOUT WRITTEN PERMISSION							

HOLDER ASSEMBLY - CAP WITH TAB

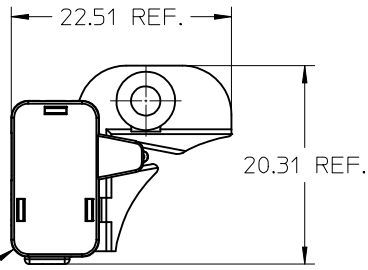

CAP WITH TAB
P/N 180417-0001
(SEE NOTE 7)

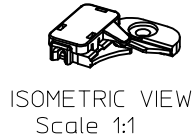
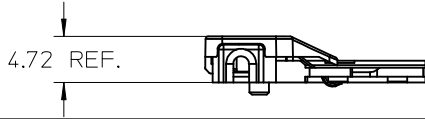

ISOMETRIC VIEW
Scale 1:1

HOLDER ASSEMBLY - CAP WITHOUT TAB

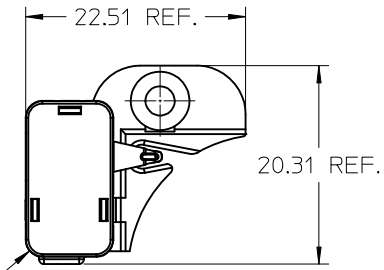

CAP WITHOUT TAB
P/N 180417-0002
(SEE NOTE 7)

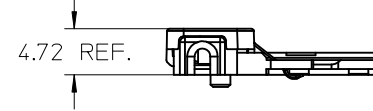

ISOMETRIC VIEW
Scale 1:1

ENTER DESCRIPTION EC NO: SSL2017-0015 DRWNL:ZAB,JANOVSKI 2016/10/12 CHKD: APPR:GMEYER 2016/10/17 REV	QUALITY SYMBOLS $\nabla F/0$ $\nabla E/0$ $\nabla D/0$	GENERAL TOLERANCES (UNLESS SPECIFIED)		DIMENSION STYLE MM ONLY		SCALE 2:1	DESIGN UNITS METRIC	THIRD ANGLE PROJECTION	
		4 PLACES \pm --- \pm --- 3 PLACES \pm --- \pm --- 2 PLACES \pm 0.13 \pm --- 1 PLACE \pm 0.25 \pm --- 0 PLACE \pm --- \pm ---	mm INCH	DRAWN BY DATE MCOLE 2012/01/30	TITLE 28 X 28MM & 38 X 38MM COB SERIES HOLDER ASSEMBLY		DOCUMENT NO. SD-180416-001		SHEET NO. 4 OF 5
		ANGULAR \pm 1/2°	MATERIAL NO. SEE CHART	THIS DRAWING CONTAINS INFORMATION THAT IS PROPRIETARY TO MOLEX INCORPORATED AND SHOULD NOT BE USED WITHOUT WRITTEN PERMISSION					
	B3	DRAFT WHERE APPLICABLE MUST REMAIN WITHIN DIMENSIONS	SIZE B	MOLEX					

10	9	8	7	6	
COB MFG	TYPE	DIM 'X'	DIM 'Y'	DIM 'Z'	DIM 'D'
CITIZEN	CLL040, CLL042, CLU044, CLU046, CLU048	28.0	28.0	0.90	24.5
LEXTAR	PB38H01.0	28.0	28.0	0.90	23.6
LUMILEDS	LUXEON 1211	28.0	28.0	1.00	21.0
SEOUL	ZC25, ZC40, ZC60	28.0	28.0	0.90	24.2
LG INNOTEK	40W/60W COB	28.0	28.0	0.82	24.5
VOSSL0H-SCHWABE	DMC12CC**D, DMC17CC**D	28.0	28.0	1.00	24.0
BRIDGELUX	V22	28.0	28.0	1.00	23.6

5	4	3	2	1	
COB MFG	TYPE	DIM 'X'	DIM 'Y'	DIM 'Z'	DIM 'D'
CITIZEN	CLL050, CLL052, CLU054, CLU056, CLU058	38.0	38.0	0.90	35.5
VOSSL0H-SCHWABE	DMC18Q***F	38.0	38.0	1.00	35.0

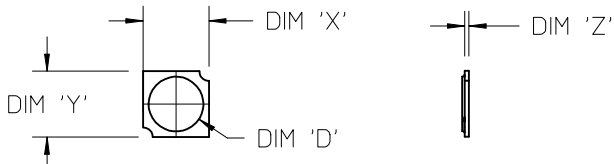

COB LED

ENTER DESCRIPTION EC NO: SSL2017-0015 DRAWN: ZABJANOVSKI 2016/10/12 CHKD: APPR: GMEYER 2016/10/17 REV: B3	QUALITY SYMBOLS =0 =0	GENERAL TOLERANCES (UNLESS SPECIFIED) <table border="1"> <thead> <tr> <th></th> <th>mm</th> <th>INCH</th> </tr> </thead> <tbody> <tr> <td>4 PLACES</td> <td>± ---</td> <td>± ---</td> </tr> <tr> <td>3 PLACES</td> <td>± ---</td> <td>± ---</td> </tr> <tr> <td>2 PLACES</td> <td>± 0.13</td> <td>± ---</td> </tr> <tr> <td>1 PLACE</td> <td>± 0.25</td> <td>± ---</td> </tr> <tr> <td>0 PLACE</td> <td>± ---</td> <td>± ---</td> </tr> </tbody> </table>		mm	INCH	4 PLACES	± ---	± ---	3 PLACES	± ---	± ---	2 PLACES	± 0.13	± ---	1 PLACE	± 0.25	± ---	0 PLACE	± ---	± ---	DIMENSION STYLE MM ONLY	SCALE 1:1	DESIGN UNITS METRIC	THIRD ANGLE PROJECTION
		mm	INCH																					
	4 PLACES	± ---	± ---																					
	3 PLACES	± ---	± ---																					
	2 PLACES	± 0.13	± ---																					
1 PLACE	± 0.25	± ---																						
0 PLACE	± ---	± ---																						
ANGULAR ±1/2°		DRAWN BY MCOLE DATE 2012/01/30	CHECKED BY MCOLE DATE 2012/05/15	TITLE 28 X 28MM & 38 X 38MM COB SERIES HOLDER ASSEMBLY																				
DRAFT WHERE APPLICABLE MUST REMAIN WITHIN DIMENSIONS		MATERIAL NO. SEE CHART	DOCUMENT NO. SD-180416-001																					
		SIZE B	THIS DRAWING CONTAINS INFORMATION THAT IS PROPRIETARY TO MOLEX INCORPORATED AND SHOULD NOT BE USED WITHOUT WRITTEN PERMISSION			SHEET NO. 5 OF 5																		