

Ultra-low Power Integrated Ultrasonic Time-of-Flight Range Sensor

CH101 HIGHLIGHTS

The CH101 is a miniature, ultra-low-power ultrasonic Time-of-Flight (ToF) range sensor. Based on Chirp's patented MEMS technology, the CH101 is a system-in-package that integrates a PMUT (Piezoelectric Micromachined Ultrasonic Transducer) together with an ultra-low-power SoC (system on chip) in a miniature, reflowable package. The SoC runs Chirp's advanced ultrasonic DSP algorithms and includes an integrated microcontroller that provides digital range readings via I²C.

Complementing Chirp's long-range CH201 ultrasonic ToF sensor product, the CH101 provides accurate range measurements to targets at distances up to 1.2m. Using ultrasonic measurements, the sensor works in any lighting condition, including full sunlight to complete darkness, and provides millimeter-accurate range measurements independent of the target's color and optical transparency. The sensor's Field-of-View (FoV) can be customized and enables simultaneous range measurements to multiple objects in the FoV. Many algorithms can further process the range information for a variety of usage cases in a wide range of applications.

The CH101-00ABR is a Pulse-Echo product intended for range finding and presence applications using a single sensor for transmit and receive of ultrasonic pulses. The CH101-02ABR is a frequency matched Pitch-Catch product intended for applications using one sensor for transmit and a second sensor for receiving the frequency matched ultrasonic pulse.

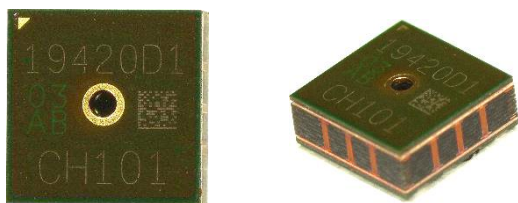

DEVICE INFORMATION

PART NUMBER	OPERATION	PACKAGE
CH101-00ABR	Pulse-Echo	3.5 x 3.5 x 1.26mm LGA
CH101-02ABR	Pitch-Catch	3.5 x 3.5 x 1.26mm LGA

RoHS and Green-Compliant Package

APPLICATIONS

- Augmented and Virtual Reality
- Robotics
- Obstacle avoidance
- Mobile and Computing Devices
- Proximity/Presence sensing
- Ultra-low power remote presence-sensing nodes
- Home/Building automation

FEATURES

- Fast, accurate range-finding
 - Operating range from 4 cm to 1.2m
 - Sample rate up to 100 samples/sec
 - 1.0 mm RMS range noise at 30 cm range
 - Programmable modes optimized for medium and short-range sensing applications
 - Customizable field of view (FoV) up to 180°
 - Multi-object detection
 - Works in any lighting condition, including full sunlight to complete darkness
 - Insensitive to object color, detects optically transparent surfaces (glass, clear plastics, etc.)
- Easy to integrate
 - Single sensor for receive and transmit
 - Single 1.8V supply
 - I²C Fast-Mode compatible interface, data rates up to 400 kbps
 - Dedicated programmable range interrupt pin
 - Platform-independent software driver enables turnkey range-finding
- Miniature integrated module
 - 3.5 mmx 3.5 mm x 1.26 mm, 8-pin LGA package
 - Compatible with standard SMD reflow
 - Low-power SoC running advanced ultrasound firmware
 - Operating temperature range: -40°C to 85°C
- Ultra-low supply current
 - 1 sample/s:
 - 13 μ A (10 cm max range)
 - 15 μ A (1.0 m max range)
 - 30 samples/s:
 - 20 μ A (10 cm max range)
 - 50 μ A (1.0 m max range)

Table of Contents

CH101 Highlights	1
Device Information	1
Applications	1
Features	1
1 Simplified Block Diagram	3
2 Absolute Maximum Ratings	4
3 Package Information	5
3.1 8-Pin LGA	5
3.2 Pin Configuration	5
3.3 Pin Descriptions	6
3.4 Package Dimensions	6
4 Electrical Characteristics	7
5 Electrical Characteristics (Cont'd)	8
6 Typical Operating Characteristics	9
7 Detailed Description	10
7.1 Theory of Operation	10
7.2 Device Configuration	10
8 Applications	11
8.1 Chirp CH101 Driver	11
8.2 Object Detection	11
8.3 Interfacing to the CH101 Ultrasonic Sensor	11
8.4 Device Modes of Operation:	12
8.5 Layout Recommendations:	13
8.6 PCB Reflow Recommendations:	14
8.7 Use of Level Shifters	14
9 Typical Operating Circuits	15
10 Ordering Information	16
10.1 Part Number Designation	16
10.2 Package Marking	17
10.3 Tape & Reel Specification	17
10.4 Shipping Label	17
11 Revision History	19

1 SIMPLIFIED BLOCK DIAGRAM

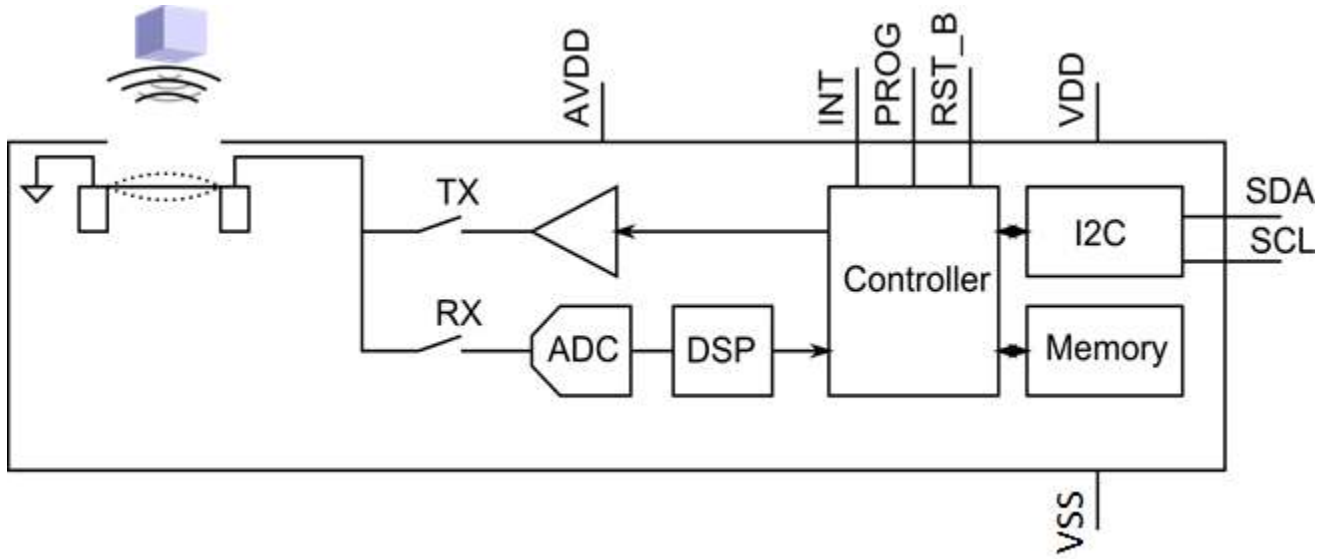

Figure 1. Simplified Block Diagram

2 ABSOLUTE MAXIMUM RATINGS

PARAMETER	MIN.	TYP.	MAX.	UNIT
AVDD to VSS	-0.3		2.2	V
VDD to VSS	-0.3		2.2	V
SDA, SCL, PROG, RST_N to VSS	-0.3		2.2	V
Electrostatic Discharge (ESD)				
Human Body Model (HBM) ⁽¹⁾	-2		2	kV
Charge Device Model (CDM) ⁽²⁾	-500		500	V
Latchup	-100		100	mA
Temperature, Operating	-40		85	°C
Relative Humidity, Storage			90	%RH
Continuous Input Current (Any Pin)	-20		20	mA
Soldering Temperature (reflow)			260	°C

Table 1. Absolute Maximum Ratings

Notes:

1. HBM Tests conducted in compliance with ANSI/ESDA/JEDEC JS-001-2014 Or JESD22-A114E
2. CDM Tests conducted in compliance with JESD22-C101

3 PACKAGE INFORMATION

3.1 8-PIN LGA

DESCRIPTION	DOCUMENT NUMBER
CH101 Mechanical Integration Guide	AN-000158
CH101 and CH201 Ultrasonic Transceiver Handling and Assembly Guidelines	AN-000159

Table 2. 8-Pin LGA

3.2 PIN CONFIGURATION

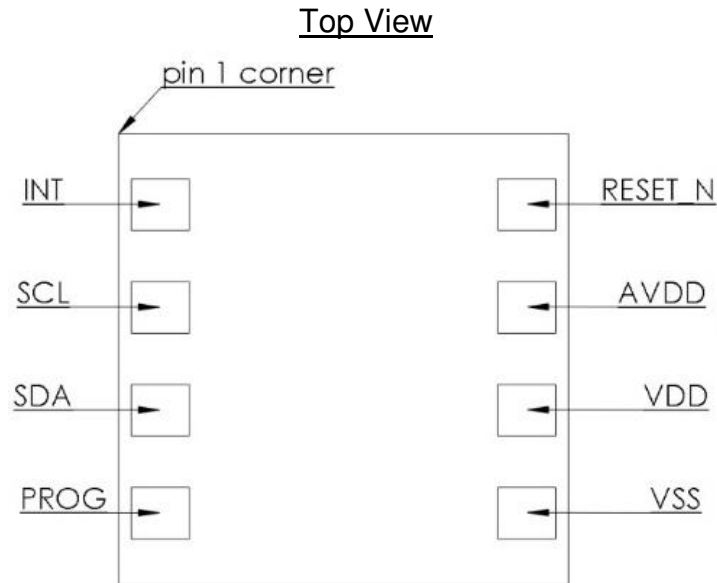

Figure 2. Pin Configuration (Top View)

3.3 PIN DESCRIPTIONS

PIN	NAME	DESCRIPTION
1	INT	Interrupt output. Can be switched to input for triggering and calibration functions
2	SCL	SCL Input. I ² C clock input. This pin must be pulled up externally.
3	SDA	SDA Input/Output. I ² C data I/O. This pin must be pulled up externally.
4	PROG	Program Enable. Cannot be floating.
5	VSS	Power return.
6	VDD	Digital Logic Supply. Connect to externally regulated 1.8V supply. Suggest common connection to AVDD. If not connected locally to AVDD, bypass with a 0.1μF capacitor as close as possible to VDD I/O pad.
7	AVDD	Analog Power Supply. Connect to externally regulated supply. Bypass with a 0.1μF capacitor as close as possible to AVDD I/O pad.
8	RESET_N	Active-low reset. Cannot be floating.

Table 3. Pin Descriptions

3.4 PACKAGE DIMENSIONS

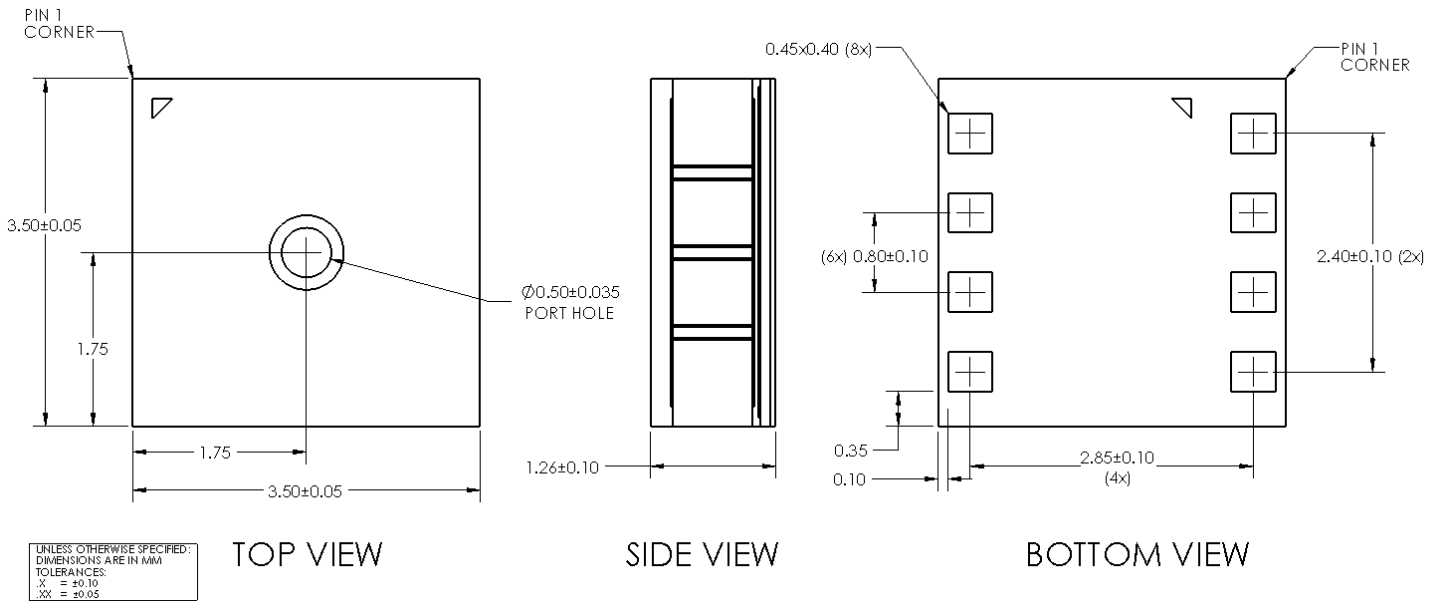

Figure 3. Package Dimensions

4 ELECTRICAL CHARACTERISTICS

AVDD = VDD = 1.8VDC, VSS = 0V, T_A = +25°C, min/max are from T_A = -40°C to +85°C, unless otherwise specified.

PARAMETER	SYMBOL	CONDITIONS	MIN	TYP	MAX	UNITS
POWER SUPPLY						
Analog Power Supply	AVDD		1.62	1.8	1.98	V
Digital Power Supply	VDD		1.62	1.8	1.98	V
ULTRASONIC TRANSMIT CHANNEL						
Operating Frequency				175		kHz
TXRX OPERATION (GPR FIRMWARE USED UNLESS OTHERWISE SPECIFIED)						
Maximum Range	Max Range	Wall Target		1.2 ⁽¹⁾		m
		58 mm Diameter Post		0.7		m
Minimum Range	Min Range	Short-Range F/W used		4 ⁽²⁾		cm
Measuring Rate (Sample/sec)	SR				100	S/s
Field of View	FoV		Configurable up to 180°			deg
Current Consumption (AVDD + VDD)	I _s	SR=1S/s, Range=10 cm		13		μA
		SR=1S/s, Range=1.0m		15		μA
		SR=30S/s, Range=10 cm		20		μA
		SR=30S/s, Range=1.0m		50		μA
Range Noise	N _R	Target range = 30 cm		1.0		mm, rms
Measurement Time		1m max range		18		ms
Programming Time				60		ms

Table 4. Electrical Characteristics

Notes:

1. Tested with a stationary target.
2. For non-stationary objects. While objects closer than 4cm can be detected, the range measurement is not ensured.

5 ELECTRICAL CHARACTERISTICS (CONT'D)

AVDD = VDD = 1.8VDC, VSS = 0V, TA = +25°C, unless otherwise specified.

PARAMETER	SYMBOL	CONDITIONS	MIN	TYP	MAX	UNITS
DIGITAL I/O CHARACTERISTICS						
Output Low Voltage	V _{OL}	SDA, INT,			0.4	V
Output High Voltage	V _{OH}	INT	0.9*V _{VDD}			V
I ² C Input Voltage Low	V _{IL I2C}	SDA, SCL			0.3*V _{VDD}	V
I ² C Input Voltage High	V _{IH I2C}	SDA, SCL	0.7*V _{VDD}			V
Pin Leakage Current	I _L	SDA,SCL, INT(Inactive), TA=25°C			±1	μA
DIGITAL/I²C TIMING CHARACTERISTICS						
SCL Clock Frequency	f _{SCL}	I ² C Fast Mode		400		kHz

Table 5. Electrical Characteristics (Cont'd)

6 TYPICAL OPERATING CHARACTERISTICS

AVDD = VDD = 1.8VDC, VSS = 0V, T_A = +25°C, unless otherwise specified.

Typical Beam Pattern – MOD_CH101-03-01 Omnidirectional FoV module (Measured with a 1m² flat plate target at a 30 cm range)

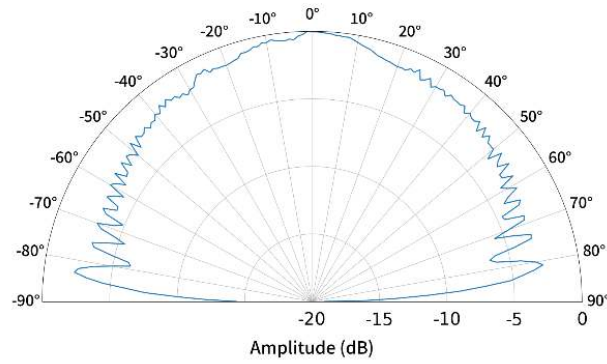

Figure 4. Beam pattern measurements of CH101 module

7 DETAILED DESCRIPTION

7.1 THEORY OF OPERATION

The CH101 is an autonomous, digital output ultrasonic rangefinder. The Simplified Block Diagram, previously shown, details the main components at the package-level. Inside the package are a piezoelectric micro-machined ultrasonic transducer (PMUT) and system-on-chip (SoC). The SoC controls the PMUT to produce pulses of ultrasound that reflect off targets in the sensor's Field of View (FoV). The reflections are received by the same PMUT after a short time delay, amplified by sensitive electronics, digitized, and further processed to produce the range to the primary target. Many algorithms can further process the range information for a variety of usage cases in a wide range of applications.

The time it takes the ultrasound pulse to propagate from the PMUT to the target and back is called the time-of-flight (ToF). The distance to the target is found by multiplying the time-of-flight by the speed of sound and dividing by two (to account for the round-trip). The speed of sound in air is approximately 343 m/s. The speed of sound is not a constant but is generally stable enough to give measurement accuracies within a few percent error.

7.2 DEVICE CONFIGURATION

A CH101 program file must be loaded into the on-chip memory at initial power-on. The program, or firmware, is loaded through a special I²C interface. Chirp provides a default general-purpose rangefinder (GPR) firmware that is suitable for a wide range of applications. This firmware enables autonomous range finding operation of the CH101. It also supports hardware-triggering of the CH101 for applications requiring multiple transceivers. Program files can also be tailored to the customer's application. Contact Chirp for more information.

CH101 has several features that allow for low power operation. An ultra-low-power, on-chip real-time clock (RTC) sets the sample rate and provides the reference for the time-of-flight measurement. The host processor does not need to provide any stimulus to the CH101 during normal operation, allowing the host processor to be shut down into its lowest power mode until the CH101 generates a wake-up interrupt. There is also a general-purpose input/output (INT) pin that is optimized to be used as a system wake-up source. The interrupt pin can be configured to trigger on motion or proximity.

8 APPLICATIONS

8.1 CHIRP CH101 DRIVER

Chirp provides a compiler and microcontroller-independent C driver for the CH101 which greatly simplifies integration. The CH101 driver implements high-level control of one or more CH101s attached to one or more I²C ports on the host processor. The CH101 driver allows the user to program, configure, trigger, and readout data from the CH101 through use of C function calls without direct interaction with the CH101 I²C registers. The CH101 driver only requires the customer to implement an I/O layer which communicates with the host processor's I²C hardware and GPIO hardware. Chirp highly recommends that all designs use the CH101 driver.

8.2 OBJECT DETECTION

Detecting the presence of objects or people can be optimized via software, by setting the sensor's full-scale range (FSR), and via hardware, using an acoustic housing to narrow or widen the sensor's field-of-view. The former means that the user may set the maximum distance at which the sensor will detect an object. FSR values refer to the one-way distance to a detected object.

In practice, the FSR setting controls the amount of time that the sensor spends in the listening (receiving) period during a measurement cycle. Therefore, the FSR setting affects the time required to complete a measurement. Longer full-scale range values will require more time for a measurement to complete.

Ultrasonic signal processing using the CH101's General Purpose Rangefinder (GPR) Firmware will detect echoes that bounce off the first target in the Field-of-View. The size, position, and material composition of the target will affect the maximum range at which the sensor can detect the target. Large targets, such as walls, are much easier to detect than smaller targets. Thus, the associated operating range for smaller targets will be shorter. The range to detect people will be affected by a variety of factors such as a person's size, clothing, orientation to the sensor and the sensor's field-of-view. In general, given these factors, people can be detected at a maximum distance of 0.7m from the CH101 sensor.

For additional guidance on the detection of people/objects using the NEMA standard, *AN-000214 Presence Detection Application Note* discusses the analysis of presence detection using the Long-Range CH201 Ultrasonic sensor.

8.3 INTERFACING TO THE CH101 ULTRASONIC SENSOR

The CH101 communicates with a host processor over the 2-wire I²C protocol. The CH101 operates as an I²C slave and responds to commands issued by the I²C master.

The CH101 contains two separate I²C interfaces, running on two separate slave addresses. The first is for loading firmware into the on-chip program memory, and the second is for in-application communication with the CH101. The 7-bit programming address is 0x45, and the 7-bit application address default is 0x29. The application address can be reprogrammed to any valid 7-bit I²C address.

The CH101 uses clock stretching to allow for enough time to respond to the I²C master. The CH101 clock stretches before the acknowledge (ACK) bit on both transmit and receive. For example, when the CH101 transmits, it will hold SCL low after it transmits the 8th bit from the current byte while it loads the next byte into its internal transmit buffer. When the next byte is ready, it releases the SCL line, reads the master's ACK bit, and proceeds accordingly. When the CH101 is receiving, it holds the SCL line low after it receives the 8th bit in a byte. The CH101 then chooses whether to ACK or NACK depending on the received data and releases the SCL line.

The figure below shows an overview of the I²C slave interface. In the diagram, 'S' indicates I²C start, 'R/W' is the read/write bit, 'Sr' is a repeated start, 'A' is acknowledge, and 'P' is the stop condition. Grey boxes indicate the I²C master actions; white boxes indicate the I²C slave actions.

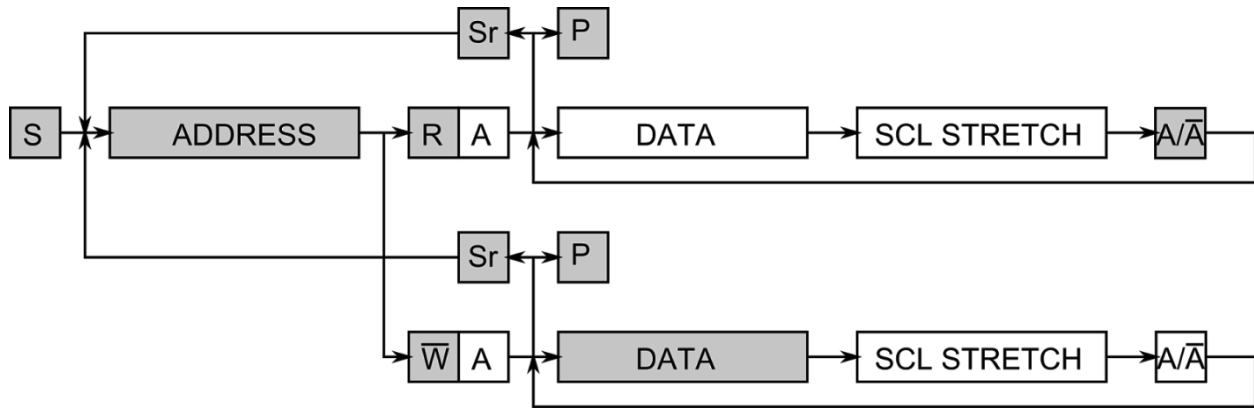

Figure 5. CH101 I²C Slave Interface Diagram

8.4 DEVICE MODES OF OPERATION:

FREE-RUNNING MODE

In the free-running measurement mode, the CH101 runs autonomously at a user specified sample rate. In this mode, the INT pin is configured as an output. The CH101 pulses the INT pin high when a new range sample is available. At this point, the host processor may read the sample data from the CH101 over the I²C interface.

HARDWARE-TRIGGERED MODE

In the hardware triggered mode, the INT pin is used bi-directionally. The CH101 remains in an idle condition until triggered by pulsing the INT pin. The measurement will start with deterministic latency relative to the rising edge on INT. This mode is most useful for synchronizing several CH101 transceivers. The host controller can use the individual INT pins of several transceivers to coordinate the exact timing.

CH101 BEAM PATTERNS

The acoustic Field of View is easily customizable for the CH101 and is achieved by adding an acoustic housing to the transceiver that is profiled to realize the desired beam pattern. Symmetric, asymmetric, and omnidirectional (180° FoV) beam patterns are realizable.

An example beam pattern is shown in the Typical Operating Characteristics section of this document and several acoustic housing designs for various FoV's are available from Chirp.

**8.5 LAYOUT RECOMMENDATIONS:
RECOMMENDED PCB FOOTPRINT**

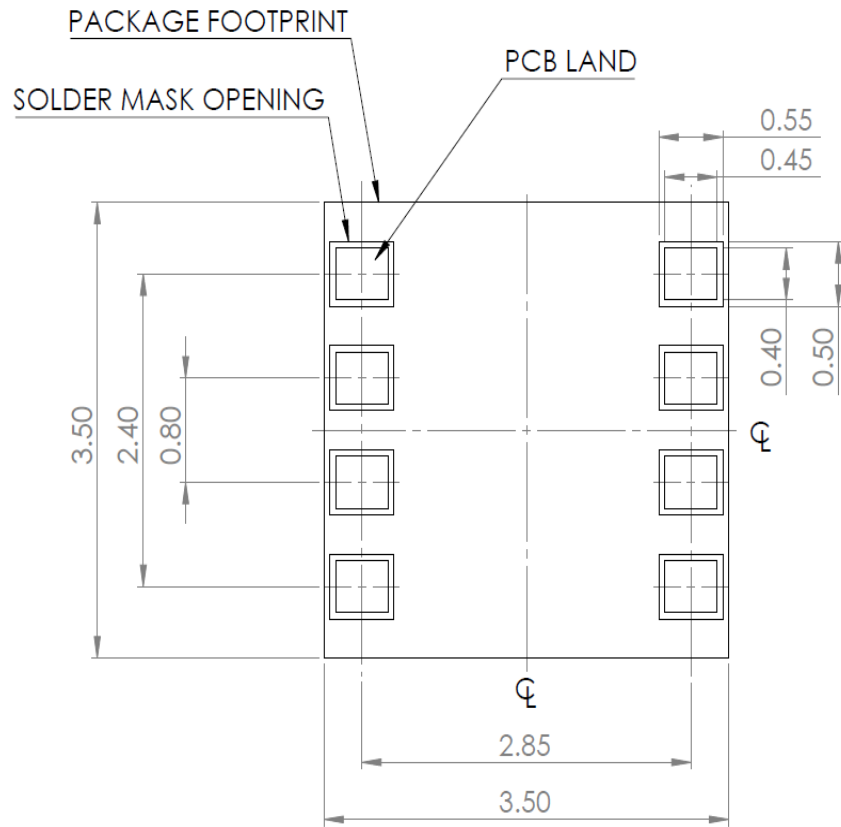

Dimensions in mm

Figure 6. Recommended PCB Footprint

8.6 PCB REFLOW RECOMMENDATIONS:

See App Note *AN-000159, CH101 and CH201 Ultrasonic Transceiver Handling and Assembly Guidelines.*

8.7 USE OF LEVEL SHIFTERS

While the use of autosense level shifters for all the digital I/O signal signals is acceptable, special handling of the INT line while using a level shifter is required to ensure proper resetting of this line. As the circuit stage is neither a push-pull nor open-drain configuration (see representative circuit below), it is recommended that level shifter with a manual direction control line be used. The TI SN74LVC2T45 Bus Transceiver is a recommended device for level shifting of the INT signal line.

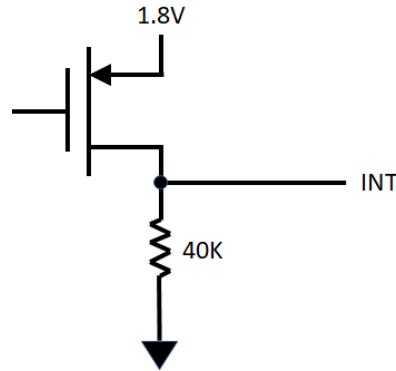

Figure 7. INT Line I/O Circuit Stage

9 TYPICAL OPERATING CIRCUITS

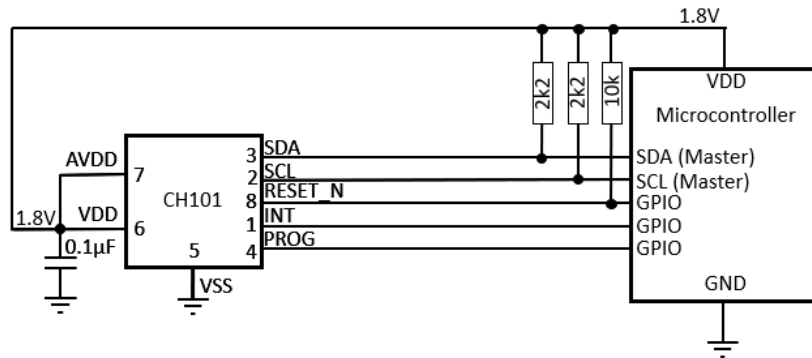

Figure 8. Single Transceiver Operation

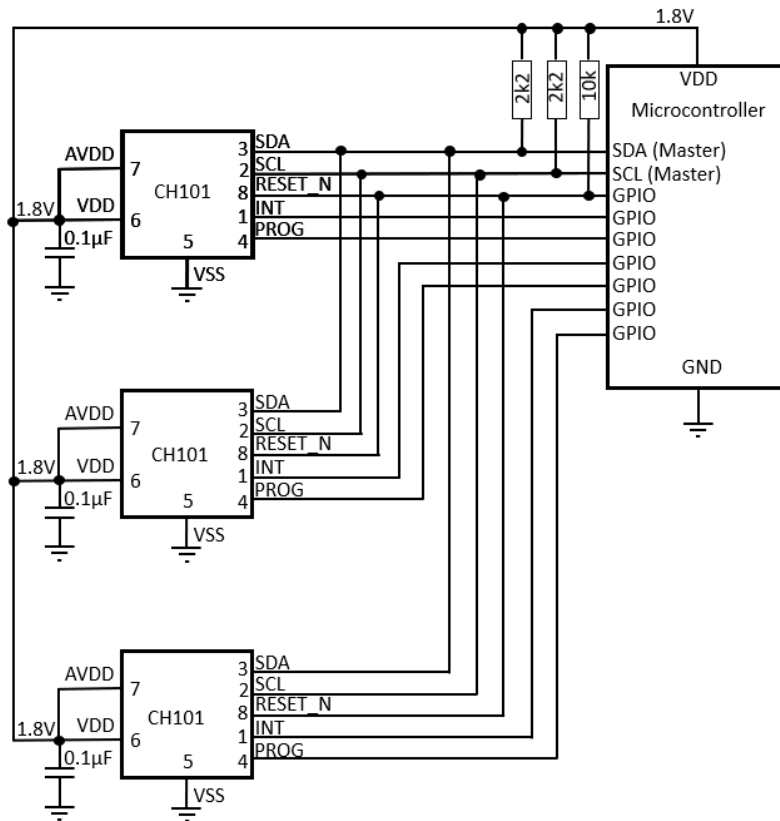

Figure 9. Multi- Transceiver Operation

10 ORDERING INFORMATION

10.1 PART NUMBER DESIGNATION

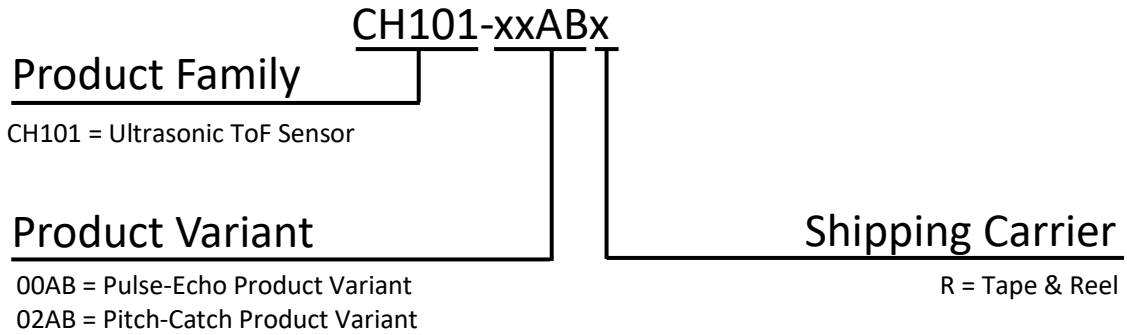

Figure 10. Part Number Designation

This datasheet specifies the following part numbers

PART NUMBER	OPERATION	PACKAGE BODY	QUANTITY	PACKAGING
CH101-00ABR	Pulse-Echo	3.5 mm x 3.5 mm x 1.26 mm LGA-8L	1,000	7" Tape and Reel
CH101-02ABR	Pitch-Catch	3.5 mm x 3.5 mm x 1.26 mm LGA-8L	1,000	7" Tape and Reel

Table 6. Part Number Designation

10.2 PACKAGE MARKING

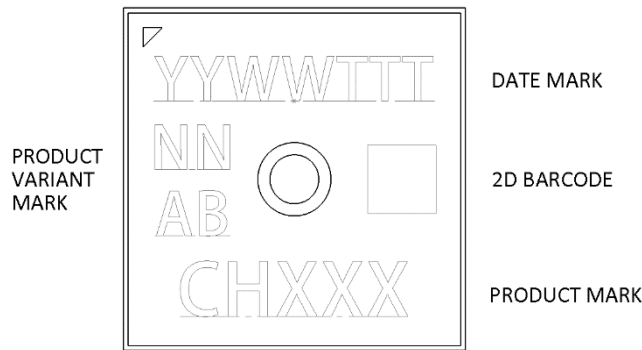

Figure 11. Package Marking

10.3 TAPE & REEL SPECIFICATION

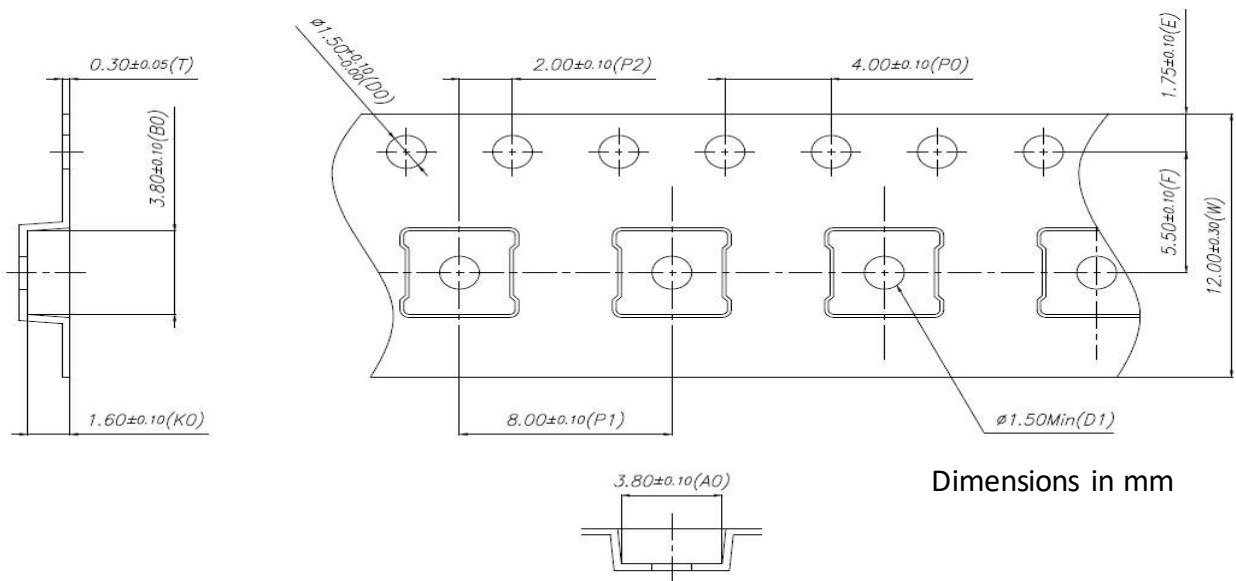

Figure 12. Tape & Reel Specification

10.4 SHIPPING LABEL

A Shipping Label will be attached to the reel, bag and box. The information provided on the label is as follows:

- Device: This is the full part number
- Lot Number: Chirp manufacturing lot number
- Date Code: Date the lot was sealed in the moisture proof bag
- Quantity: Number of components on the reel
- 2D Barcode: Contains Lot No., quantity and reel/bag/box number

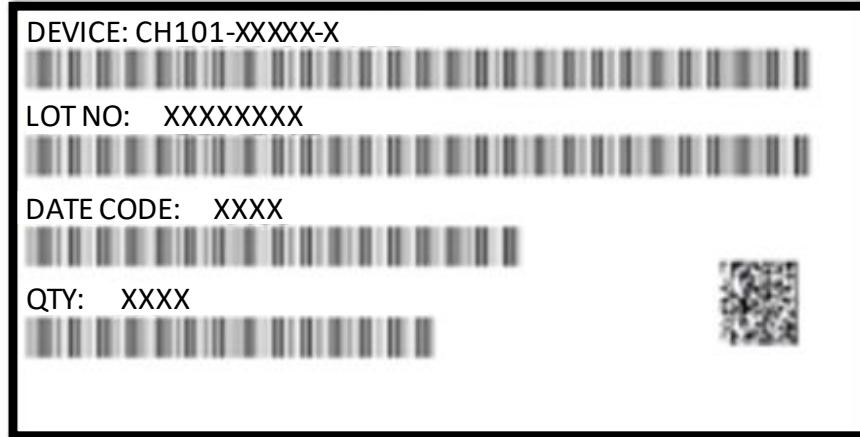

Figure 13. Shipping Label

11 REVISION HISTORY

DATE	REVISION	CHANGES
09/30/2019	1.0	Initial Release
10/22/2019	1.1	Changed CH-101 to CH101. Updated figure 7 to current markings.
07/17/2020	1.2	Format Update. Incorporated "Maximum Ratings Table" and "Use of Level Shifters" section.
09/22/2020	1.3	Fixed minor typos
12/23/2020	1.4	Updated Package Dimensions with tolerances

This information furnished by Chirp Microsystems, Inc. (“Chirp Microsystems”) is believed to be accurate and reliable. However, no responsibility is assumed by Chirp Microsystems for its use, or for any infringements of patents or other rights of third parties that may result from its use. Specifications are subject to change without notice. Chirp Microsystems reserves the right to make changes to this product, including its circuits and software, in order to improve its design and/or performance, without prior notice. Chirp Microsystems makes no warranties, neither expressed nor implied, regarding the information and specifications contained in this document. Chirp Microsystems assumes no responsibility for any claims or damages arising from information contained in this document, or from the use of products and services detailed therein. This includes, but is not limited to, claims or damages based on the infringement of patents, copyrights, mask work and/or other intellectual property rights.

Certain intellectual property owned by Chirp Microsystems and described in this document is patent protected. No license is granted by implication or otherwise under any patent or patent rights of Chirp Microsystems. This publication supersedes and replaces all information previously supplied. Trademarks that are registered trademarks are the property of their respective companies. Chirp Microsystems sensors should not be used or sold in the development, storage, production or utilization of any conventional or mass-destructive weapons or for any other weapons or life threatening applications, as well as in any other life critical applications such as medical equipment, transportation, aerospace and nuclear instruments, undersea equipment, power plant equipment, disaster prevention and crime prevention equipment.

©2020 Chirp Microsystems. All rights reserved. Chirp Microsystems and the Chirp Microsystems logo are trademarks of Chirp Microsystems, Inc. The TDK logo is a trademark of TDK Corporation. Other company and product names may be trademarks of the respective companies with which they are associated.



©2020 Chirp Microsystems. All rights reserved.